

JANUARY

Radio-Electronics

TELEVISION SERVICING HIGH FIDELITY

HUGO GERNSBACK, Editor

Special Report: 1961 TV Receiver Circuitry

Transistor Paging Receiver For Citizens Band

Zener Diodes Simplified



'Headie-Talkie'— New Communicator

See page 4

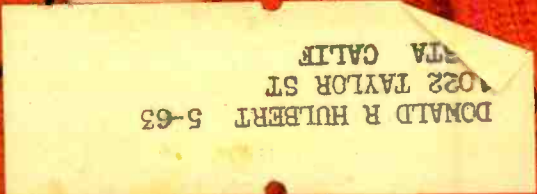



SYLVANIA-6AU4-GTA

WITH

SARONG CATHODE

HELPS YOU

“WRAP-UP” PROFITS!

New life-giving, profit-building features are built into every SYLVANIA-6AU4-GTATV-damper tube. Consider, for one feature, the SYLVANIA SARONG CATHODE and how it adds dependability to tube life. SARONG provides uniform spacing between cathode and plate—reduces possibility of plate-to-cathode arc-over. SARONG prevents the build-up of “whiskers” inside the cathode sleeve that can develop during other types of coating processes—reduces possibilities of cathode-to-heater arc-over.

Consider, too, the “pigtail” heater in SYLVANIA-6AU4-GTA. Welded securely to the stem-lead, it reduces heater “hot spots” and the possibilities of heater burnout. More . . . rectangular top and bottom micas with exceptionally wide slots increase the resistance of dc leakage paths, further reduce the possibilities of internal arc-over and breakdown.

There’s extra profit assurance, too, with SYLVANIA-6AU4-GTA. Every one of them is tested for shorts, emission and the ability to withstand arc-over at 5000-volts peak inverse on the anode.

So, “wrap up” the profits you make by putting a “damper” on callbacks. When you ask your distributor for 6AU4-GTA’s, always specify SYLVANIA.

Electronic Tubes Division, Sylvania Electric Products Inc., 1740 Broadway, New York 19, New York.



SYLVANIA

Subsidiary of **GENERAL TELEPHONE & ELECTRONICS**



If you have some knowledge of Radio or Television or Electronics now and want to **BECOME A PROFESSIONAL SERVICE TECHNICIAN**



Over 40 years ago, J. E. Smith, founder of the National Radio Institute, pioneered in teaching Radio by the home study method. Today, this magnificent building is completely devoted to NRI's Radio-TV Electronics training. Here up-to-date laboratory and research facilities are constantly testing new developments and improved methods of training men for Radio-TV Electronics careers.

All-Practice Method



NRI's Professional TV Servicing Training is practical, complete. You make tests and experiments to help thoroughly understand TV problems. You get equipment to build a 5" Oscilloscope, a 17" picture tube and all components for building a TV receiver. Comprehensive Color TV manuals also included. You learn how experts diagnose TV defects, get knowledge of professional techniques. Mail the coupon for free catalog now. NATIONAL RADIO INSTITUTE, Washington 16, D. C.

you will want to investigate the special **ALL-PRACTICE TRAINING PLAN** developed for men like you by the **OLDEST AND LARGEST** home study **Radio-Television school**

MAIL THIS TO NRI NOW

National Radio Institute, Dept. 1AFT, Washington 16, D.C.

Accredited Member National Home Study Council

Please send me a FREE copy of your catalog "How to Reach the Top in TV Servicing." I understand no salesman will call.

Name..... Age.....

Address.....

City..... Zone..... State.....

(Note: This training is NOT for beginners)

Radio-Electronics

JANUARY, 1961

Formerly RADIO-CRAFT — Incorporating SHORT WAVE CRAFT — TELEVISION NEWS — RADIO & TELEVISION*

OVER FIFTY YEARS OF ELECTRONIC PUBLISHING

Hugo Gernsback
..... Editor and Publisher

M. Harvey Gernsback
..... Editorial Director

Fred Shunaman
..... Managing Editor

Robert F. Scott, W2PWG
..... Technical Editor

Larry Steckler
..... Associate Editor

Jack Darr
..... Television Consultant

Elizabeth Stalcup
..... Production Manager

Fernando Martinez
..... Art Director

Wm. Lyon McLaughlin
..... Tech. Illustration Director

Fred Neinast
..... Art Associate

Lee Robinson
..... Director, Advertising Sales

John J. Lamson
..... Eastern Sales Manager

G. Aliquo
..... Circulation Manager

Adam J. Smith
..... Director, Newsstand Sales

Robert Fallath
..... Promotion Manager

Average Paid Circulation
Over 163,000



ON THE COVER

(Story on page 80)

The futuristic hat, which probably won't be seen in the Easter parade, supports the antenna for the miniature FM transmitter the young lady has in her hand. The matching master receiver is on the right. Together, they make a handy team wherever short-range wireless communication is useful.

Color original by
Vega Electronics Corp.

Radio-Electronics is indexed in
Applied Science & Technology Index
(Formerly *Industrial Arts Index*)

editorial

31 "Undersea Radar"—Hugo Gernsback

television

42 TV DESIGNS FOR 1961—Wayne Lemons

radio

39 Pocket VHF Receiver an Interesting Project—I. Queen

51 Construct This Handie-Talkie That Covers the 10-Meter Band—Leonard J. D'Airo

62 Easily Built Citizens-Band Radio Pages Listener—J. H. Thomas

80 New Short-Range Communicator (Cover Feature)—C. Arthur Foy

what's new

41 Pictorial Reports of New Developments

test instruments

38 Transistors in Parallel-T—A. H. Taylor

54 Transformer in a Line Plug—Milton White

60 Do You Know the Ultra-Kap?—Capacitor Engineering Dept. of Centralab

85 Circuit Substitution Speeds Transistor Radio Servicing—C. J. Borlaug

industrial electronics

55 And Now the Transistorized Portable Scope—Tom Jaski

59 Protect That Voltage Regulator

64 Strain Gauges, What They Can Do—Arthur S. Kramer

audio-high fidelity

36 Puzzled About Hum?—Norman H. Crowhurst

40 Bass-Reflex Speaker Enclosures

72 Intercom Super Duper Model I, A Worth-while Construction Project—Peter J. Vogelgesang

electronics

32 Zener Diodes Simplified—Donald L. Stoner

50 Measure V-R Tube Current—Elmer J. Kaping

74 Electronic Judge (Build It Yourself!) Spots the Winner—Sam Garson

95 Single-Curve Chart—E. T. Thiersch

the departments

118 Business and People
128 Correction
20 Correspondence
124 New Books
121 New Literature

111 New Patents
96 New Products
108 New Tubes and Semiconductors
6 News Briefs
114 Noteworthy Circuits

100 TECHNICIANS' ASSOCIATIONS
OF US AND CANADA
104 Technotes
116 Try This One
112 50 Years Ago

Radio-Electronics January, 1961, Vol. XXXII, No. 1. Published monthly at Mt. Morris, Ill., by Gernsback Publications, Inc. Second-class postage paid at Mt. Morris, Ill. Copyright 1960 by Gernsback Publications, Inc. All rights reserved under Universal, International and Pan-American Copyright Conventions.

Subscription Rates: U.S., U.S. possessions and Canada, \$5.00 for one year; \$9.00 for two years; \$12.00 for three years. Pan-American countries \$6.00 for one year; \$11.00 for two years; \$15.00 for three years. All other countries \$6.50 a year; \$12.00 for two years; \$16.50 for three years.

Subscriptions: Address correspondence to Radio-Electronics, Subscriber Service, 154 West 14th St., New York 11, N.Y. When requesting a change of address, please furnish an address label from a recent issue. Allow one month for change of address.

Gernsback Publications, Inc., Executive, Editorial and Advertising Offices, 154 West 14th St., New York 11, N.Y. Telephone ALgonquin 5-7755. Hugo Gernsback, Chairman of the Board; M. Harvey Gernsback, President; G. Aliquo, Secretary.

Advertising Representatives: Los Angeles: Harker-Husted-Coughlin, 400 South Alvarado St. Tel. DUmkirk 7-2328. San Francisco: Harker-Husted-Coughlin, 444 Market St., Tel. GARfield 1-0151. Chicago: 8631 East Prairie Road, Skokie, Ill. Tel. ORchard 5-3740.

Foreign Agents: Great Britain: Atlas Publishing and Distributing Co., Ltd., 18 Bride Lane, London E.C. 4.

Postmaster: If undeliverable, send Form 3579 to: RADIO-ELECTRONICS, 154 West 14th St., New York 11, N.Y. *Trademark registered U. S. Pat. Office.

BREAK THROUGH TO HIGHER PAY in ELECTRONICS TV-RADIO

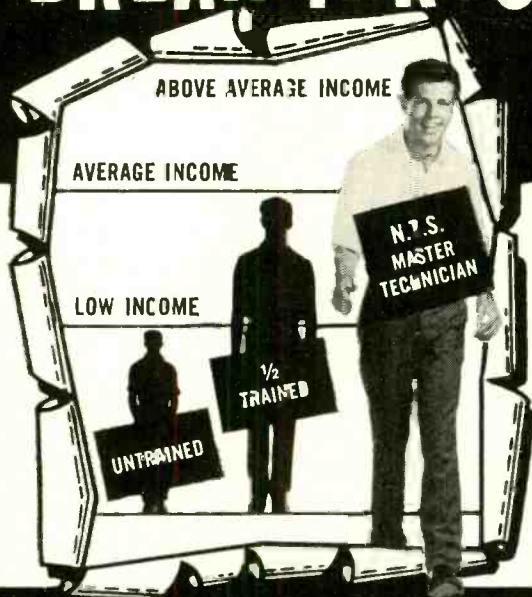

START NOW! Break through the Earning Barrier that stops half-rained men. N.T.S. "All-Phase" training prepares you — at home in spare time — for a high-paying CAREER in Electronics — TV — Radio as a MASTER TECHNICIAN. One Master Course at One Low Tuition trains you for unlimited opportunities in All Phases: Servicing, Communications, Preparation F.C.C. License, Broadcasting, Manufacturing, Automation, Radar and Micro-Waves, Missile and Rocket Projects.

A more rewarding job... a secure future... a richer, fuller life can be yours! As an **N.T.S. MASTER TECHNICIAN** you can go straight to the top in industry... or in your own profitable business.

You work on actual job projects



SUCCEED IN MANY HIGH-PAYING JOBS LIKE THESE...

- TV-Radio Sales, Service and Repair
- Profitable Business of Your Own
- Communications Technician — F.C.C. License
- Hi-Fi, Stereo & Sound Recording Specialist
- TV-Radio Broadcasting Operator
- Technician in Computers & Missiles
- Electronics Field Engineer
- Specialist in Microwaves & Servomechanisms
- Expert Trouble Shooter
- All-Phase Master Technician

19 BIG KITS YOURS TO KEEP

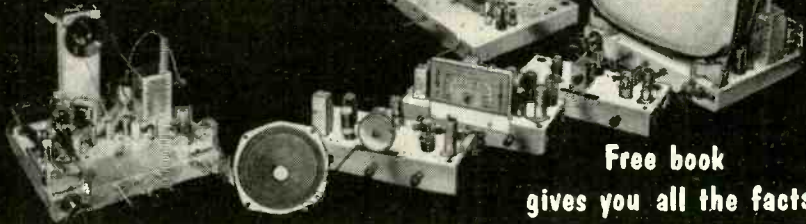

Free book gives you all the facts

NATIONAL TECHNICAL SCHOOLS

WORLD-WIDE TRAINING SINCE 1905
4000 SO. FIGUEROA ST., LOS ANGELES 37, CALIF., U.S.A.
Write Dept. RG-11



RESIDENT TRAINING AT LOS ANGELES
If you wish to take your training in our Resident School at Los Angeles, start now in our big, modern Shops and Labs. Work with the latest Auto and Diesel engines — all types — fuel injection, automatic transmissions, all power equipment — most complete facilities offered by any school. Expert, friendly instructors. Graduate Employment Service. Help in finding home near school — and part time job while you learn.
WRITE FOR SPECIAL RESIDENT SCHOOL CATALOG AND INFORMATION



ACCREDITED MEMBER
... the only nationally recognized accrediting agency for private home study schools.

N.T.S. Shop-Tested HOME TRAINING is **Better, More Complete, Lower Cost**... and it is your key to the most fascinating, opportunity-filled industry today!

YOU LEARN QUICKLY AND EASILY THE N.T.S. SHOP-TESTED WAY

You get lessons, manuals, job projects, unlimited consultation, graduate advisory service. You build a Short Wave-Long Wave Superhet Receiver, plus a large-screen TV set from the ground up, with parts we send you at no addi-

tional cost. You also get a Professional Multitester for your practical job projects.

EARN AS YOU LEARN... WE SHOW YOU HOW!

Many students pay for entire tuition — and earn much more — with spare time work they perform while training. You can do the same... we show you how.

**SEND FOR INFORMATION NOW...
TODAY! IT COSTS YOU NOTHING
TO INVESTIGATE.**

N.T.S. HOME TRAINING is

- Classroom Developed
- Lab-Studio Planned
- Shop-Tested
- Industry-Approved
- Specifically Designed for Home Study



**MAIL
COUPON
NOW**
for
FREE BOOK
and
**ACTUAL
LESSON**

**NO OBLIGATION!
NO SALESMAN WILL CALL**

NATIONAL TECHNICAL SCHOOLS

WORLD-WIDE TRAINING SINCE 1905

Mail Now To
National Technical Schools, Dept. RG-11
4000 S. Figueroa St., Los Angeles 37, Calif.
Please rush FREE Electronics-TV-Radio "Opportunity" Book and Actual Lesson. No Salesman will call.

Name _____ Age _____

Address _____

City _____ Zone _____ State _____

Check here if interested ONLY in Resident Training at Los Angeles.

VETERANS: Give date of discharge _____



News Briefs

Broadcasting 40 Years Old

Pioneer broadcast station KDKA of Pittsburgh celebrated its 40th birthday Nov. 2, 1960. It went on the air officially Nov. 2, 1920, to broadcast the election returns, announcing the victory of Warren Harding. Earlier, it had been operating for some time as an amateur broadcast station in the garage of Westinghouse engineer Frank Conrad. The anniversary was marked with special broadcasts, including one from the building in Westinghouse Electric Corp.'s East Pittsburgh plant from which the first broadcast was sent.

Underground Radio Sets Record

Messages have been sent more than 100 miles from a transmitter buried deep in a California mine shaft, reports Space Electronics Corp., which has been carrying on underground radio experiments for more than a year.

While the idea of underground radio is not entirely new (some work had been done by J. Harris Rogers as early as 1919), this system appears to work on a new principle. It uses the boundary layer between earth and air as a guide rather than attempting to send the signals directly through the earth.

As explained by its developers, the system works somewhat like this: A transmitting station below the earth sends out signals from a buried antenna pointed in the direction of the receiver. From the buried antenna, electromagnetic waves are generated in the media. These waves can travel in several directions, including an upward path to the earth's floor above.

In view of the discontinuity that exists between the earth—a conducting medium, and the atmosphere—a virtually nonconducting medium, a type of channel is created along the earth's surface. Favoring the direction in which the antenna is aimed, the waves travel along this channel toward the receiving site.

It is the channel formed by the discontinuity between earth and air that enables the effective transmission. This channel roughly extends from a few miles beneath the earth's surface to several miles above it. Both transmitter and receiver, however, can remain safely buried.

In addition to its obvious military applications, Space Electronics sees numerous commercial possibilities for

the technique. It can, for example, offer a means of communication immune to ice and snow storms, hurricanes and tornadoes, vandalism and other hazards.

World Has New Length Standard

The international meter is now the length of 1,650,763.73 wavelengths of the orange-red line of light given out by krypton 86. The new standard replaces the platinum-iridium bar which has been kept in France as the standard meter since 1889.

The meter is the base (by Act of Congress) of American linear measurements as well as measurements in all countries using the metric system, and in all scientific laboratories in the world.

The new standard will increase the unification of systems of measurement throughout the world. In the past, it has been necessary to

send meter bars to France for calibration against the standard, and it became obvious that—in spite of the care taken in calibration—some of the secondary standards were longer than others. The new standard is immediately accessible anywhere, and therefore will simplify the work of scientists.

Radio Pioneer Passes

Dr. W. R. G. Baker, radio engineer since 1920 and one of the leaders in the development of television, died Oct. 30, 1960, at the age of 67.

Dr. Baker started his engineering career with the General Electric Co. in 1916. When the company established a separate radio department in 1920, Dr. Baker was the design engineer and was instrumental in getting short-wave broadcast station WGY on the air in 1922. Later he was concerned with the high-powered experimental stations W2XAD

ELECTRONIC HIGHLIGHTS OF 1960

As another busy year of the electronics age passed, we saw 19 US space satellites launched, 12 successfully. All carried electronic instrumentation. On one single firing, two satellites were placed in orbit simultaneously. This leaves the US with 14 satellites in earth orbit, 2 around the sun, for 1960. Nine of them are still transmitting. It was a year that saw electronic medicine grow with devices to control and stimulate a weak heart. A supplemental

JANUARY

Thermoplastic picture recording. Revolutionary method of recording TV or motion pictures combines some advantages of film with the instant recording and playback of magnetic video tape. (March, page 6.)

FEBRUARY

Messages from outer space? Radiotelescope set up at Green Bank, W. Va., is listening for intelligence-bearing radio signals from other planets and solar systems. (May, page 18.)

MAY

High-power radio deadly? Pulses of radio energy beamed from a forward-scatter radio transmitter in Great Britain can injure anyone in front of the directional antenna up to a mile away. (July, page 6.)

JUNE

Piezoelectricity. Two new compounds exhibiting a strong piezoelectric effect were discovered. They are zinc oxide and cadmium sulphide.

JULY

Amateurs bounce signals off moon. Amateur radio operators in San Carlos, Calif., and Medfield, Mass., communicated with each other by bouncing their 1,000-watt 1296-mc signals off the moon. (October, page 6.)

AUGUST

Project Echo. Transcontinental telephone conversations via radio beams reflected from satellite ECHO

heart was kept on time by electronic impulses. The year saw Alaska get "White Alice," a dependable radio communications system, based on forward tropospheric scatter; and BMEWS (Ballistic Missile Early Warning System) set up in Thule, Greenland.

For the home, there were transistor TV's, battery-powered of course; air ionizers and an upswing in FM radio, with multiplexing stereo being tested and a decision pending from the FCC on which one will be used.

were demonstrated by Bell Telephone Laboratory scientists. (October, page 6.)

AUGUST

Reflecting ring to orbit earth? A plan for a man-made radio reflecting ring girdling the earth in the ionosphere is to be tested by the Air Force. Billions of tiny antenna doublets, each half as thick as a human hair, would be spread in the ionosphere by an orbiting satellite. Reflecting ring would be used to relay signals from point to point much as the Project Echo balloon did. (October, page 10.)

AUGUST

Telemetering pilots. The physical condition of a pilot and the craft he is flying will be continuously monitored from the ground. Reports on pilot's condition within a fraction of a second show whether he is going into an unsafe condition. (October, page 6.)

OCTOBER

Light amplifier. A true light amplifier, the apparatus uses light to stimulate light, in a manner similar to the use of feedback in radio circuit. The device is the laser, or optical maser. (December, page 8.)

OCTOBER

Relay satellite Courier. A more sophisticated approach to world-wide communications via space satellites is the Signal Corps delayed-repeater satellite Courier. The 500-pound sphere contains 300 or more pounds of electronic gear for receiving signals from earth, recording them on tape and retransmitting them on request. (December, page 6.)

Best-Selling Records from Columbia and many other great labels

AVAILABLE IN **REGULAR HIGH-FIDELITY** OR **STEREO**

MORE JOHNNY'S GREATEST HITS Small World A Capitol Sings Plus 10 more JOHNNY MATHIS	DVOŘAK "NEW WORLD" SYMPHONY NO. 5 CLEVELAND ORCH. SZELL	MARY MARTIN in RODGERS & HAMMERSTEIN'S THE SOUND OF MUSIC Original Broadway Cast	DORIS DAY HOORAY FOR HOLLYWOOD	LORD'S PRAYER MORMON TABERNACLE CHOIR BATTLE HYMN OF THE REPUBLIC THE LORD'S PRAYER—9 MORE	HITS FROM THE MOVIES featuring PERCY FAITH'S original THEME FROM "A SUMMER PLACE" DORIS DAY—Pilot Talk plus 10 more	WAGNER: "Die Meistersinger" Overture "The Flying Dutchman" Overture Prelude and Great Friday Spell from "Parsifal" BRUNO WALTER COLUMBIA SYMPHONY ORCH.	THE PLATTERS Encore of Golden Nite Twilight Time My Prayer Only You 9 more
8. Also: Let It Rain, Stairway to the Sea, Flame of Love, etc.	57. "Glowing intensity, snap and brilliance"—High Fidelity	10. Complete score. "Perfectly wonderful"—Ed Sullivan	19. Over the Rainbow, Night and Day, Easy to Love, 9 more	30. Also: Blessed Are They That Mourn, Come Ye Saints, etc.	17. Also: Tony Bennett—Smile; Vic Damone—Gigi; etc.	15. "A memorable experience"—American Record Guide	20. Also: Great Pretender, Magic Touch, Enchanted, etc.
TCHAIKOVSKY: 1812 Overture Capriccio Italien ANTAL DORATI MINNEAPOLIS SYMPHONY ORCH.	ELLA FITZGERALD sings GERSHWIN VOL. 1	LISTENING IN DEPTH AN INTRODUCTION TO COLUMBIA STEREOPHONIC SOUND	GRAND CANYON SUITE PHILADELPHIA ORCH. ORMANDY	TILL ROGER WILLIAMS April Love Tammy Jalousie 9 MORE	LISZT PIANO CONCERTOS No. 1 and 2 PHILIPPE ENTREMONT, piano Philadelphia Orchestra Eugene Ormandy	FOLK SONGS SING ALONG WITH MITCH	SCHEHERAZADE BERNSTEIN NEW YORK PHILHARMONIC
1. "Most exciting reading I've ever heard"—High Fidelity	46. 12 great Gershwin hits: Man I Love, But Not For Me, etc.	9. 16 classical and popular selections—in STEREO only	12. This brilliant musical painting is an American classic	55. Also: Arrividerci Roma; Oh, My Papa; Moonlight Love; etc.	43. "Entremont has a feeling for romantic music"—McCall's	16. Skip to My Lou, On Top of Old Smoky, Oh Susanna, 12 more	3. "A persuasive, sensuous performance"—Listen

COLUMBIA RECORD CLUB now offers new members

ANY 5

in your choice of **REGULAR** or **STEREO** **\$1.97** FOR ONLY **RETAIL VALUE UP TO \$30.90**

if you join the Club now and agree to purchase as few as 5 selections from the more than 200 to be offered in the coming 12 months

OUTSIDE SHELLEY BERMAN A VITE RECORD	OFFENBACH: Caire Parisienne BIZET: CARMEN HIGHLIGHTS Andre Kostelanetz	THE FABULOUS JOHNNY CASH DON'T TAKE YOUR GUNS TO TOWN RUN SOFTLY, BLUE RIVER PLUS 10 OTHERS	Rhapsody in Blue An American in Paris Leonard Bernstein plays Gershwin	GOLDEN VIBES LIONEL HAMPTON with reeds and rhythm	THE FOUR LADS BREEZIN' ALONG	LET'S DANCE AGAIN! DAVID CARROLL AND HIS ORCHESTRA	ELLINGTON AND GOS
39. A popular comedy record. "Side-splitting"—Billboard	32. Melodic scores. "Glittering performance"—Billboard	61. I Still Miss Someone, That's All Over, One More Ride, etc.	18. A new recording of these 2 ever-popular Gershwin scores	26. My Funny Valentine, Smoke Gets In Your Eyes, 10 more	40. Come to Me, That Old Feeling, Long Ago, 9 more	34. Pretty Baby, Swamp Fire, Bouncing Ball, 10 more	63. Solitude, Where or When, Dancing in the Dark, 5 more
THE NORMAN LUBOFF CHORUS BUT BEAUTIFUL	BRAHMS: SYMPHONY NO. 1 CLEVELAND ORCH. SZELL	REX HARRISON JULIE ANDREWS MY FAIR LADY ORIGINAL CAST RECORDING	STRAUSS WALTZES ANDRE KOSTELANETZ	BOUQUET PERCY FAITH STRINGS Tenderly Laura Speak Low	ROMANIAN RHAPSODIES 1 & 2 HUNGARIAN RHAPSODIES 1 & 2 PHILADELPHIA ORCH. ORMANDY	THE SOUND OF JAZZ COUNT BASIE - BILLIE HOLIDAY JIMMY BUSHING JIMMY GIUFFRÈ TRIO	Tchaikovsky: NUTCRACKER SUITE Ravel: BOLERO - LA VALSE
14. Blue Moon, Fools Rush In, Don't Worry 'bout Me, 9 more	21. "Szell interprets it wonderfully." Rev. of Recorded Music	27. Rain in Spain, I Could Have Danced All Night, etc.	13. Tales from the Vienna Woods, Blue Danube, 8 others	28. Also: Song from Moulin Rouge, Ebb Tide, etc.	59. "Superbly played...exciting listening"—Amer. Record Guide	53. Wild Man Blues, Fine and Mellow, I Left My Baby, 5 more	38. Superbly played by one of Europe's finest orchestras

Here's an offer that enables you to acquire a superb record library—in regular high-fidelity OR stereo-fidelity—in truly remarkable savings!

All 32 of the records shown here are now available in both regular high-fidelity and stereo (except No. 9—Listening In Depth—stereo only). As a new member, you may have ANY 5 of these records—in your choice of regular high-fidelity OR stereo—ALL 5 for only \$1.97. AND JUST LOOK AT THE WIDE SELECTION OF RECORDS... 32 in all—from Columbia AND many other great labels! That's right—you not only have a choice of best-selling albums by Columbia's own great artists—but also the most popular albums by favorite recording stars from many other record companies.

TO RECEIVE YOUR 5 RECORDS FOR \$1.97—mail the coupon today. Be sure to indicate whether you want your five records (and all future selections) in regular high-fidelity or stereo. Also indicate which Club Division best suits your musical taste: Classical; Listening and Dancing; Broadway, Movies, Television and Musical Comedies; Jazz.

HOW THE CLUB OPERATES: Each month the Club's staff of music experts selects outstanding records from every field of music. These selections are fully described in the Club Magazine, which you receive free each month.

You may accept the monthly selection for your Division... or take any of the wide variety of other records offered in the Magazine, from all Divisions... or take NO record in any particular month.

Your only membership obligation is to purchase five selections from the more than 200 records to be offered in the coming 12 months. Thereafter, you have no further obligation to buy any additional records... and you may discontinue your membership at any time.

FREE BONUS RECORDS GIVEN REGULARLY. If you wish to continue as a member after purchasing five records, you will receive—FREE—a Bonus record of your choice for every two additional selections you buy—a 50% dividend!

The records you want are mailed and billed to you at the regular list price of \$3.98 (Classical \$4.98; occasional Original Cast recordings somewhat higher), plus a small mailing and handling charge. Stereo records are \$1.00 more.

NOTE: Stereo records must be played only on a stereo record player. If you do not now own one, by all means continue to acquire regular high-fidelity records. They will play with true-to-life fidelity on your present phonograph and will sound even more brilliant on a stereo phonograph if you purchase one in the future.

Columbia Record Club, Terre Haute, Ind.

SEND NO MONEY — Mail Coupon Today!

COLUMBIA RECORD CLUB, Dept. 245-8

Terre Haute, Indiana

I accept your special offer and have circled at the right the numbers of the five records I wish to receive for \$1.97, plus small mailing and handling charge.

Send me 5 records and all future selections in (check one) REGULAR STEREO

... and enroll me in the following Division of the Club: (check one Division only)

Classical Listening & Dancing Jazz Broadway, Movies, Television & Musical Comedies

I understand that I may select records from any Division. I agree to purchase five selections from the more than 200 to be offered during the coming 12 months, at regular list price plus small mailing and handling charge. Thereafter, if I decide to continue my membership, I am to receive a 12" Bonus record of my choice FREE for every two additional selections I accept.

Name..... (Please Print)

Address.....

City.....ZONE.....State.....

APO, FPO addresses: write for special offer CANADA: Prices slightly higher; 1111 Leslie St., Don Mills, Ont. If you want this membership credited to an established Columbia or Epic record dealer, authorized to accept subscriptions, fill in:

Dealer's Name..... and Address..... 23

CIRCLE 5 NUMBERS

- | | | |
|----|----|----|
| 1 | 18 | 39 |
| 3 | 19 | 40 |
| 8 | 20 | 43 |
| 9 | 21 | 46 |
| 10 | 26 | 53 |
| 12 | 27 | 55 |
| 13 | 28 | 57 |
| 14 | 30 | 59 |
| 15 | 32 | 61 |
| 16 | 34 | 63 |
| 17 | 38 | |

BS-MF (REG) BS-LP (STER)

© Columbia, © Epic, © Marcas Reg. © Columbia Record Club, Inc., 1961

WORLD FAMOUS Simpson 260!

TRADEMARK

**RUGGED
PRINTED
CIRCUIT!**



still
only
\$43.95

Complete with leads and
Operator's Manual.
Also available in
Roll-Top model at
only . . . \$49.95

**...the VOM that outsells
all others combined**

**ONLY SIMPSON'S 260® VOM CONVERTS
INTO SEVEN DIFFERENT TESTERS!**

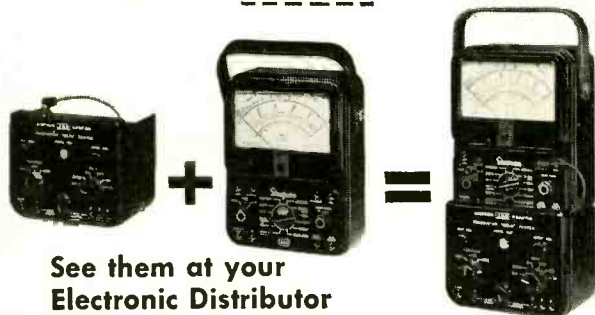

See them at your
Electronic Distributor

SIMPSON ELECTRIC COMPANY

5219 West Kinzie Street, Chicago 44, Illinois

Phone: EStebrook 9-T121

In Canada: Bach-Simpson Ltd., London, Ontario

WORLD'S LARGEST MANUFACTURER OF ELECTRONIC TEST EQUIPMENT

Adapters
TRANSISTOR TESTER
DC VTVM
TEMPERATURE TESTER
AC AMMETER
AUDIO WATTMETER
MICROVOLT ATTENUATOR
BATTERY TESTER

**Write for
Bulletin
No. 2062**

and W2XAF, which became famous in most parts of the world.

Possibly Dr. Baker's greatest contribution to the electronic art was the organization and direction of the two national television systems committees, the first of which recommended to the FCC the standards



for black-and-white TV broadcasting in 1941. The second, in 1953, laid the foundations for the set of engineering standards used in present color TV.

Dr. Baker was a past president of IRE, and was president of the Electronics Industries Association (EIA) for two terms. He was the recipient of many awards and honorary degrees as well as other tokens of recognition, one of the most striking of which was the naming of the television station at Schenectady, WGRB, with his initials. He was vice president of General Electric, in charge of the electronics department, at the time of his retirement in 1957.

Electronics Soothes Babies

A device that simulates the sound of a mother's heartbeat causes newborn babies to sleep better and cry less, states Dr. Lee Salk, brother of the inventor of the polio vaccine. A device embodying the principle is being developed by Sonotone, and should be on the market in the near future.

Dr. Salk found in his tests at the Elmhurst hospital—a New York City municipal institution—that, when newborn infants were exposed to the sound of the mother's normal heartbeat (72 double pulses per minute), they gained weight, slept better and cried less than babies not so exposed. The reduction of anxieties in infancy, according to generally accepted modern psychological theories, also leads to lesser chance of mental breakdown or instability in adulthood, Dr. Salk says.

No Color for Canada

The Board of Broadcast Governors of the Canadian broadcasting system, in a statement which said in part, "the time has not yet come for color broadcasting in Canada," has declined to authorize color broadcasting in Canada. The board had been urged by the Canadian Association of Broadcasters, the Canadian

ALLIED value-packed 1961

444-PAGE ELECTRONICS CATALOG

including special products available only from Allied

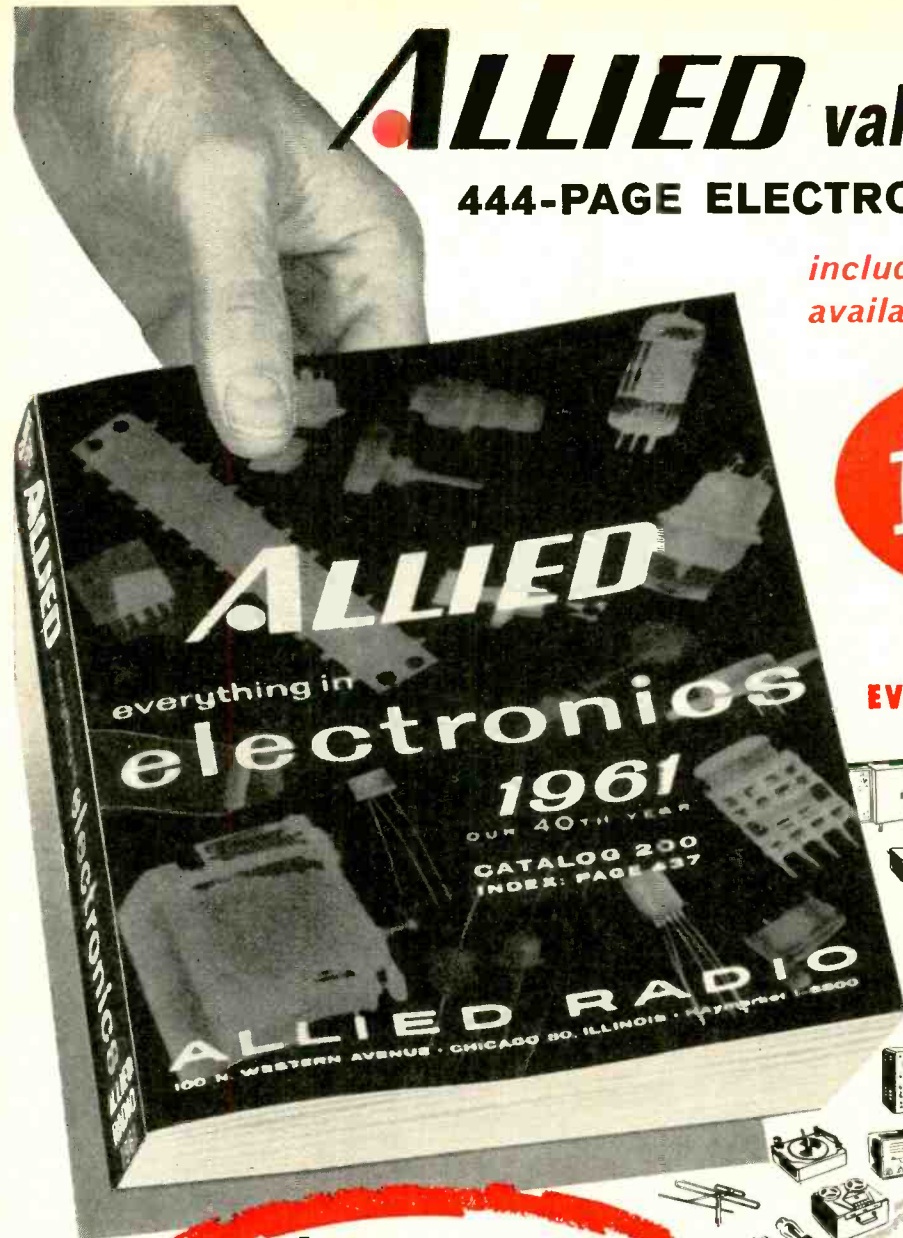

free

SAVE MOST ON EVERYTHING IN ELECTRONICS

- New Stereo Hi-Fi Systems—Everything in Hi-Fi Components
- Money-Saving, Build-Your-Own KNIGHT-KITS® for Every Need
- Best Buys in Recorders & Supplies
- Newest Public Address Systems, Paging and Intercom Equipment
- Amateur Receivers, Transmitters and Station Gear
- Citizen's Band 2-Way Radio
- Test and Laboratory Instruments
- TV Tubes, Antennas, Accessories
- Huge Listings of Parts, Tubes, Transistors, Tools, Books

BUY ON EASIEST TERMS

only \$2 down on orders up to \$50;
only \$5 down on orders up to \$200;
only \$10 down over \$200.
 Up to 24 months to pay.

ALLIED exclusives:

MONEY-SAVING KNIGHT-KITS®—truly the very best in build-your-own electronic equipment—lowest in cost, easiest to assemble, best for performance. Select from a complete line of Stereo hi-fi kits, Hobbyist kits, Test Instrument and Amateur kits. KNIGHT-KITS are an exclusive ALLIED product.

KNIGHT® STEREO HI-FI—Comparable to the best in quality, styling and performance, yet priced far lower. Select super-value KNIGHT components or complete systems and save most. Also see the largest selections of famous-name hi-fi components and money-saving ALLIED-recommended complete high-fidelity music systems.

Exclusive Allied products save you more

You get every buying advantage at ALLIED: Lowest, money-saving prices, fastest shipment, expert personal help, easiest-pay terms, satisfaction guaranteed or your money back.

send coupon today for 444-page catalog

free

ALLIED RADIO

Satisfaction Guaranteed or Your Money Back
 World's Largest Electronic Supply House



ALLIED RADIO, Dept. 2-A1
 100 N. Western Ave., Chicago 80, Ill.

Send FREE 1961 Allied Catalog No. 200

Name _____
PLEASE PRINT

Address _____

City _____ Zone _____ State _____

We're not much on FLAT TIRES



But try us on Auto Radio Controls!



Although your CENTRALAB distributor is your best source for auto radio controls, he won't be of much help to the character with the flat tire. The comprehensive CENTRALAB auto radio control line only goes back to 1942 model automobiles.

From 1942 on, though, it's a different story. CENTRALAB is the *only* control manufacturer offering a complete line of *exact replacement* auto radio controls . . . not to mention SP on/off switches. They cover 202 different automobile models, domestic *and* foreign.

CENTRALAB auto radio controls are listed in COUNTERFACTS and PHOTOFACTS, as well as in the Sams Industry Control Guide.

Changing tires is man's work, but changing auto radio controls is child's play—with CENTRALAB exact replacements.

PHOTO: BETTMAN ARCHIVE

Centralab

B-6045

THE ELECTRONICS DIVISION OF GLOBE-UNION INC.
922A EAST KEEFE AVENUE • MILWAUKEE 1, WISCONSIN
CENTRALAB CANADA LIMITED—AJAX, ONTARIO

**ELECTRONIC SWITCHES • VARIABLE RESISTORS • CERAMIC CAPACITORS
PACKAGED ELECTRONIC CIRCUITS • ENGINEERED CERAMICS**

EIA and individual telecasters to authorize color broadcasting, using US standards.

The board noted that color TV had been "promoted expensively in the US since 1953, but only 500,000 color sets are in operation, compared with 52,000,000 black-and-white receivers.

Thermogen will light buoy

Three thermoelectric generators have been ordered by the Coast Guard to power off-shore light buoys and other navigational aids. The generators, according to General Instrument Corp., who developed

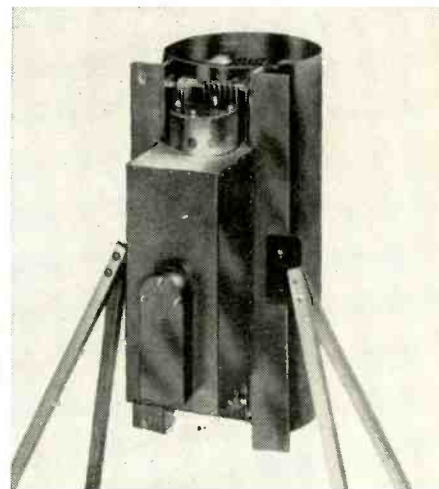

them, are enclosed in a 20-inch high, circular windscreen with heat-dissipating fins inside, and a square monel metal generator housing 5 x 6 x 12 inches which holds the semiconductor thermopiles which produce the current. Heated by propane gas, they are expected to operate continuously and unattended on \$15 worth of gas. The system also includes a nickel-cadmium storage battery.

Future Phones to Translate

Telephones that will make it possible for people speaking different languages to talk directly to each other were predicted by Dr. Edwin G. Schneider of Sylvania in a speech to the Telephone Association of New England. The automatic language-translating phones, he said, would use advanced type of data-processing and communications devices already in existence.

More Multifunction Tubes

Following on the announcement of the Compactron (RADIO-ELECTRONICS, September 1960, page 6) come reports of new multiple tubes from Sylvania and RCA. At the EIA-IRE meeting at Syracuse late last year, N. C. John and B. Lankford of RCA described two multifunction tubes, a triode-heptode rf amplifier-converter, and pentode-triode-double-diode, intended for an if amplifier, detector and first audio. These tubes, which come in regular 9-pin envelopes, make possible a car radio with only

how to get a Commercial FCC LICENSE

An FCC License, Or Your Money Back!

Completion of the Master Course (both Sections) will prepare you for a First Class Commercial Radio Telephone License with a Radar Endorsement. Should you fail to pass the FCC examination for this license after successfully completing the Master Course, you will receive a full refund of all tuition payments. This guarantee is valid for the entire period of your enrollment agreement.

Get This Handy Pocket Electronics Data Guide

Free

Puts all the commonly used conversion factors, formulas, tables, and color codes at your fingertips. Yours absolutely free if you mail the coupon today. No further obligation.

FREE

**Successful
Electronics
Training**

find out how . . .

1. You can handle the new electronic devices.
2. You can solve the problems that stump your fellow technicians.
3. Training is Job Insurance when employment is tough to find . . . and more money for you when times are good.

CLEVELAND INSTITUTE OF ELECTRONICS

RE49A 4900 Euclid Ave. Cleveland 3, Ohio

Mail
Coupon
NOW!



good training
doesn't cost . . .
it pays!

get all three **FREE!**

Increase Your Technical Knowledge

Get a government license plus an understanding of such electronic applications as computers . . . industrial electronics . . . radar . . . communications . . . and many more.

Accredited by the National Home Study Council

Cleveland Institute of Electronics

Desk RE49A, 4900 Euclid Ave., Cleveland 3, Ohio

Please send Free Booklets prepared to help me get ahead in Electronics. I have had training or experience in Electronics as indicated below.

- | | |
|---------------------------------------------|---------------------------------------------|
| <input type="checkbox"/> Military | <input type="checkbox"/> Broadcasting |
| <input type="checkbox"/> Radio-TV Servicing | <input type="checkbox"/> Home Experimenting |
| <input type="checkbox"/> Manufacturing | <input type="checkbox"/> Telephone Company |
| <input type="checkbox"/> Amateur Radio | <input type="checkbox"/> Other _____ |

In what kind of work are you now engaged?

In what branch of Electronics are you interested?

Name _____ Age _____

Address _____

City _____ Zone _____ State _____

RE49A

ONLY FISHER HAS IT



THE FM-200
World's Finest
FM Tuner

0.5 Microvolt Sensitivity (20 db of quieting with 72-ohm antenna.)
The best figure ever achieved!

Six IF Stages — Five Limiters — Golden Cascode Front-End for a degree of selectivity, sensitivity and complete freedom from interference never attained before now.

1.5 db Capture Ratio — The best ever achieved on any FM tuner! Remarkably noise-free reception.

Exclusive MicroTune — The amazing FISHER invention that makes absolutely precise FM tuning virtually automatic! **\$229.00**

Write Today For Complete Specifications!

FISHER RADIO CORPORATION
21-51 44th Drive • Long Island City 1, N. Y.

two tubes and one transistor. Sylvania's contribution is a 10-pin tube—a 9-pin base with an extra pin in the center (RADIO-ELECTRONICS, October 1960, page 97). The series includes a double tetrode, intended for use as an rf amplifier and oscillator-mixer in FM receivers, and a triple triode to be used as rf amplifier, oscillator-mixer and afc.

New Solid-State Device Rivals Tunnel Diode

A device that consists simply of two metallic films separated by an insulating layer may make possible a whole new family of electronic apparatus. The new instrumentality—not yet named—was discovered by Ivar Giaever of the General Electric Research Laboratory. It exhibits the "tunneling" effect of a tunnel diode, at much lower voltages. The device operates at a degree or so Kelvin, at which temperature the metallic films are superconductors.

The device is simple, according to G-E scientist Ivar Giaever:

"First we evaporate or vapor deposit a strip or film of aluminum on a glass slide. We then expose this aluminum film to air for a few minutes, permitting a very thin natural oxide layer to form on the surface of the aluminum film. Finally we evaporate a lead film across the aluminum film. This sandwiches the aluminum oxide layer between the two metal films." The result is seen in the photograph. The active area of the device is the part where the two strips, separated by the insulating aluminum oxide layer, cross.

If the temperature is dropped to 1.2° Kelvin, and a voltage applied across the sandwich formed by the aluminum, lead and lead oxide, a current flows through the insulator. This "tunneling" takes place only if the insulating layer is extremely thin, say 10 atoms thick. Increasing the voltage produces a current curve somewhat like that of the tunnel diode. Between zero and 1 mv, current rises gradually. As voltage is increased further, the current curve drops steeply to about 3 mv, when it again starts to rise very rapidly.

This negative resistance effect, inventor Giaever pointed out, is independent of current direction through the device, whereas the tunnel diode is a one-way device.

While still early to predict exact applications for the device, the negative resistance effect opens possibilities as an amplifier. Since superconductivity is reduced or negated by a magnetic field, the device could be modulated by a coil wound around the center of the cross, giving a triode effect. According to Dr. Guy Suits, G-E Director of Research:

The new devices that may eventually result from a "marriage" of tunneling and superconductivity should be as different from the transistor as the transistor was from the vacuum tube, and yet they should be

able to perform many of the same functions. The discovery, upon which these future devices would be based, is so recent that all of its consequences cannot be fully determined. However, it is already adding to

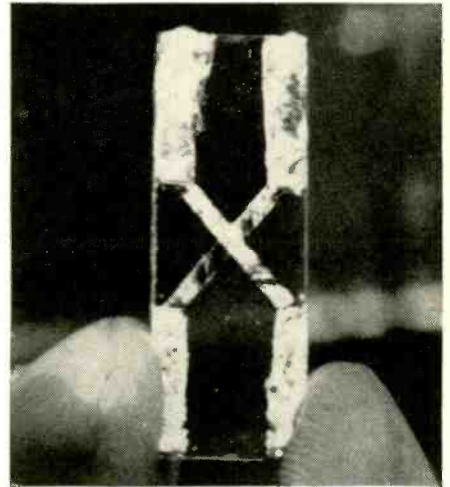

fundamental knowledge of both tunneling and superconductivity and has opened a new approach to the construction of versatile, microminiature electronic components. For example, it may be possible to make—in an entirely new way—a simple device that could function as a switch, diode, negative-resistance diode, triode, resistor or capacitor.

Ionosphere Satellite Up

The most extensive and intensive measurements of ionosphere characteristics and phenomena ever made are being taken by ionosphere satellite Explorer VII. These measurements are expected to increase greatly our knowledge of changes in the ionosphere, including variations due to sunlight and darkness and to solar and geomagnetic storms. The various sensors carried by the satellite are checking the concentration, distribution and temperatures or energies of the ions and electrons that make up the ionospheric belt. The satellite will also measure the quantity, momentum and energy of the particles of cosmic dust, or micrometeorites, as well as indirectly measuring the density of matter in the space through which it passes.

The satellite, which weighs 90 lbs., is 30 inches in diameter and orbits around the earth, coming as close as 258 miles at its nearest point and reaching out 1,423 miles at its most distant. It makes one revolution every 113 minutes.

Telephones Go Electronic

Tiny neon tubes and memory banks like those used in computers are the main features of a new kind of telephone central office being tried out in Morris, Ill., by Bell Telephone Labs and Illinois Bell. The neon tubes connect lines when the voltage of one line is raised 60 volts and the other lowered by the same amount.

(Continued on page 16)

READY TO SERVE YOU!

OVER
1500

CLAROSTAT
DISTRIBUTORS

with

CLAROSTAT
"Right Replacements"

RTV CONTROLS

Completely factory-made and assembled — ready for use right from the carton — eliminates all fuss, bother and cussing because they fit right and work right just as you get them.

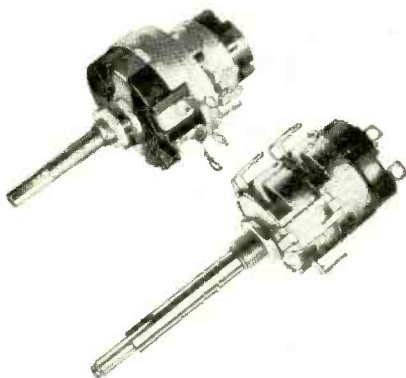

GREENOHM RESISTORS

King of them all — for price and dependability. Available in all popular values. Ideal for replacement purposes especially where overloading burns out less rugged resistors.



PICK-A-SHAFT CONTROLS

Pick the one you need — wire-wound or carbon — from the many popular values available. Then choose your shaft — snap it in. Need a switch? Ad-a-Switch attaches to control in seconds — no sweat, no bother ...



WRITE FOR COMPLETE CATALOG, OR ASK YOUR DISTRIBUTOR

CLAROSTAT MFG. CO., INC.

DOVER, NEW HAMPSHIRE

In Canada: CANADIAN MARCONI CO., LTD., Toronto 17, Ont.



LEARN

SUBJECTS OFFERED AT NO COST TO YOU:

- ① TRANSISTOR FUNDAMENTALS—complete coverage of transistor theory without the use of mathematics.
- ② GUIDE-MATIC POWER HEADLIGHT CONTROL (Autronic Eye)—lecture and lab.
- ③ TWILIGHT SENTINEL ELECTRIC HEADLIGHT SWITCH—lecture and lab.
- ④ TROUBLE-SHOOTING PROCEDURES for dead or weak low voltage auto radio tuners and trigger circuits.
- ⑤ LECTURE AND LAB. PRACTICE ON "SIGNAL SEEKER" AND "WONDER BAR" auto radio tuners and trigger circuits.
- ⑥ TRANSISTOR CIRCUIT TROUBLE-SHOOTING—lecture and lab. work analyzing defects in transistor circuits.
- ⑦ HYBRID-TYPE AUTOMOBILE RADIOS—low voltage tube and output transistor circuits. Lecture and lab.
- ⑧ DELCO-MATIC ALL-TRANSISTOR GARAGE DOOR OPERATORS—lecture and lab.
- ⑨ AUTO PORTABLE RADIOS—lectures and lab. practice on all-transistor portable radios. Get prepared for the all-transistor auto radio that will appear in the next few years.

THE LATEST ON

TRANSISTORS AND AUTOMOTIVE ELECTRONICS 9 SUBJECTS AVAILABLE TO YOU AT THE FREE DELCO RADIO-GUIDE LAMP ADVANCED TRAINING SCHOOL. One week of instruction. No lab. fees. No tuition charge. Textbooks supplied.

In 1960 over 900 electronics technicians completed our one-week course. You, too, can receive this same valuable training in 1961. Bring yourself up to date on transistors and automotive electronics with personalized instruction at the General Motors Training Center near you. (See schedule below.)

Classes will be conducted by graduate engineers with special training in your field. Diplomas, awarded only to those who successfully complete the courses, will mean a great deal to you—and to your customers.

Register now through your local Delco Electronics Parts Distributor or write directly to Delco Radio Division, General Motors Corporation, Kokomo, Indiana, Attention: Service Manager.

GUIDE LAMP DIVISION GENERAL MOTORS CORP.
ANDERSON, INDIANA



DELCO ELECTRONICS TRAINING SCHOOL SCHEDULE						
DATE	REGION 1	REGION 2	REGION 3	REGION 4	REGION 5	REGION 6
1-16	Philadelphia		Detroit			
1-23			Detroit		Dallas	
2-6	Washington	Charlotte		St. Louis		
2-13	Washington	Atlanta			Houston	
2-20			Cincinnati		Houston	Los Angeles
2-27						Los Angeles
3-6	Tarrytown	Memphis		Omaha		
3-13	Tarrytown					
3-20		Jacksonville	Cleveland			San Francisco
4-10	Boston		Cincinnati	Kansas City	El Paso	Portland
4-17	Boston	Atlanta		Kansas City	El Paso	
5-1		New Orleans	Pittsburgh	Minneapolis		Los Angeles
5-8	Union		Pittsburgh		Oklahoma City	
5-15				Milwaukee		
5-22		Memphis	Buffalo			San Francisco
6-5	Philadelphia			Chicago	Denver	
6-12		Charlotte		Chicago		Portland
6-19			Cleveland			
6-26	Union	Atlanta		Minneapolis	Dallas	Salt Lake City



*You Can Quickly
be doing interesting
profitable work
like this!*

*Prepare now
IN SPARE TIME
AT HOME
for great opportunity
field of...*

TELEVISION

The future is YOURS in
ELECTRONICS

A fabulous field—good pay—fascinating work—a prosperous future! Good jobs or independence in your own business!

**Modern Training by Coyne
RIGHT IN YOUR OWN HOME**

Coyne brings you the first truly lower cost MODERN QUALITY Television Home Training; training designed to meet Coyne standards. Here is MODERN ELECTRONICS TRAINING with the latest on **Transistors, Printed Circuits, Remote Controls, Test Equipment, UHF, and Color.** No previous experience needed. Personal guidance by Coyne Staff.

The Institution Behind this Training

Famous for over sixty two years. COYNE occupies this entire building which is the new home of COYNE. COYNE'S modern resident training of men in Electronics, Electricity, Television and Radio has produced thousands of successful graduates.



B. W. COOKE, Jr., President

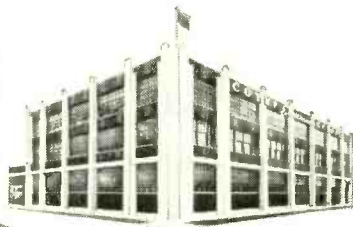

FOUNDED 1899

**COYNE
ELECTRICAL SCHOOL**

CHARTERED AS AN EDUCATIONAL INSTITUTION
NOT FOR PROFIT

1501 W. Congress Parkway, Chicago 7, Dept. 11-H5

MAIL COUPON NOW FOR DETAILS FREE

**LEARN TO
EARN IN SPARE TIME AT HOME**

COYNE offers a most practical Home Television Training. Easy to follow step-by-step instructions, fully illustrated with over 2150 photos and diagrams. **Practical Job Guides** to show you how to do actual servicing jobs—**make money early in course.** Keep your present job while in training.

Lower Cost — Easy Terms

We save you money because we don't send you—AND CHARGE FOR—a long list of parts or "put together kits," which you may not want or do not need. With Coyne Television Home Training you pay only for your training, **no costly extras.**

Even though we have added over 130 pages of lesson material recently to cover the latest Electronics subjects we have lowered our tuition while other schools have raised theirs.

**SEND COUPON OR WRITE TO ADDRESS BELOW
FOR FREE BOOK**

and full details, including Easy Payment Plan. **No obligation, no salesman will call.**

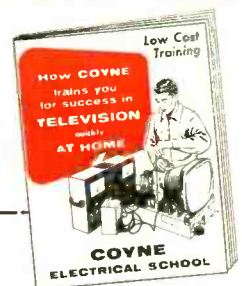

**COYNE Television
Home Training Division**

Dept. 11-H5—New Coyne Building
1501 W. Congress Parkway, Chicago 7, Illinois

Send Free Book and details on Television Home Training. This does not obligate me in any way.

Name _____

Address _____

City _____ State _____

(Unlike most other schools we do not employ salesmen.)

Quality you can count on EVERY SINGLE TIME!

AEROVOX ELECTROLYTIC CAPACITORS

Year after year Aerovox electrolytic capacitors lead the way to dependable performance and satisfied customers.

Continuous research and product development by Aerovox engineers, coupled with advanced manufacturing techniques, all add up to quality you can count on every single time! It's no wonder that you use the most popular and most complete electrolytic line in the TV-radio service industry when you use Aerovox—it's a matter of experience.

And what's more, Aerovox offers you the widest selection of top-quality capacitors with the latest technical advances available. Take a look at just a few of the highlights:

PTT-PWE... miniaturized tubular 'lytic for repair of personal transistor radios, portable TV sets, and all space-tight requirements. Feature "Polycap" plastic cases with exceptional humidity resistance characteristics.

PRS... compact "Dandee" units for trouble-free repair of series-string TV and AC-DC table radios. Aluminum cans with cardboard insulating sleeves. Available in singles, duals, and triples as well as AC rated and non-polarized units.

SRE... "Bantam" metal tubular 'lytics hermetically-sealed in aluminum cans with cardboard insulating sleeves. Smaller than the PRS but capable of handling full size loads to 85°C.

AFH... twist-prong 'lytics featuring 85°C operation... improved sealing... high-purity aluminum foil construction throughout... rugged prongs and mounting terminals. Tops for filter audio bypass applications in TV-radio and amplifier equipment.

HCB... high-capacity-low voltage 'lytics designed especially for applications such as motion picture sound equipment, electric fence controls and other low voltage applications. Feature bakelite, case which eliminates need for cardboard outer insulating tubes.



Remember . . . your local Aerovox Distributor is your one-stop source of supply. Call him today for all your capacitor needs—it pays to use Aerovox!

AEROVOX CORPORATION

DISTRIBUTOR DIVISION

NEW BEDFORD, MASSACHUSETTS

(Continued from page 12)

The 120 volts across the tube fires it and the path conducts.

Two memory tubes perform many functions, each one of which might require special circuitry in conventional exchanges. A temporary memory (called the "scratch-pad" memory) is used in placing calls, for example. A scanner checks each telephone 10 times a second. When the user picks up the telephone to make a call, a scanner reports the event

Calendar of Events

Symposium on Thermoelectric Energy Conversion, Jan. 8-12, Statler Hotel, Dallas, Tex.

National Symposium on Reliability & Quality Control, Jan. 9-11, Bellevue-Stratford Hotel, Philadelphia, Pa.

Symposium on Space Instrumentation, Jan. 16-17, Washington, D.C.

Winter Instrument-Automation Conference and Exhibit, Jan. 17-19, Sheraton-Jefferson Hotel and Kiel Auditorium, St. Louis, Mo.

Representatives Southwest, Inc., Distributor-Representative-Manufacturer Conference, Jan. 22-26, Fort Clark Guest Ranch, Bracketville, Tex.

Cleveland Electronics Conference, Jan. 31-Feb. 2, Cleveland Engineering and Scientific Center, Cleveland, Ohio.

Winter Convention on Military Electronics, Feb. 1-3, Biltmore Hotel, Los Angeles.

Second Annual ERA Convention, Feb. 1-4, Ambassador Hotel, Los Angeles.

International Solid State Circuits Conference, Feb. 15-17, University of Pennsylvania and Sheraton Hotel, Philadelphia, Pa.

Pacific Electronics Trade Show (PETS), Feb. 26-Mar. 1, Great Western Exhibit Center, Los Angeles, Calif.

and the temporary memory checks to see that no one is trying to reach the number, then supplies dial tone, speeds up its scanning to 100 times a second, records the numbers dialed and feeds the information into the switching networks to complete the call. Each time a scanner checks a phone, it also checks the circuit for that phone. Any faults are reported in detail via teletypewriter.

The temporary memory uses a "barrier-grid" cathode-ray tube. A longer memory on photographic plates, scanned with a flying spot, stores semi-permanent information. This *stored program control*, which makes it possible to extract from the memories several sets of instructions, any one of which would call for special circuitry in conventional telephone operation, makes possible services that would have been expensive or impractical in the past. Thus the users of the Morris experimental exchange will be able to:

- Use home extension phones as intercoms by dialing two digits.
- Reach frequently called numbers by dialing only two digits instead of seven.
- Have incoming calls routed to another phone when the original called line is busy.
- Dial a code which causes all subsequent incoming calls to be automatically transferred to any other number.

The information gained from the Morris experiment will be used to set up regular commercial electronic telephone central exchanges. It is expected that the first one will be in action by 1965. END

MAKE MORE MONEY

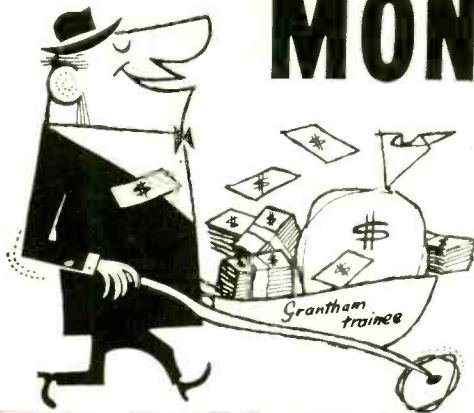

Through HOME STUDY

Grantham training is the easy way to learn more quickly—to prepare more thoroughly—for F. C. C. examinations. And your first class license is the quick, easy way to prove to your employer that you are worth more money.

This correspondence course is directed toward two major objectives—(1) to *teach* you a great deal about electronics, and (2) to prepare you to *pass* all of the F. C. C. examinations required for a first class commercial operator's license. We teach you step by step and have you practice with FCC-type tests which you send to the school for grading and comment. You prepare for your F. C. C. examinations under the watchful direction of an instructor who is especially qualified in this field.

TRAIN FOR ELECTRONICS . . .

In RESIDENT CLASSES

Grantham *resident* schools are located in four major cities—Hollywood, Seattle, Kansas City, and Washington, D. C. Regularly scheduled classes in F. C. C. license preparation are offered at all locations. New *day* classes begin every three months, and new *evening* classes begin four times a year. The day classes meet 5 days a week and prepare you for a first class F. C. C. license in 12 weeks. The evening classes meet 3 nights a week and prepare you for a first class license in 20 weeks. For more information about the Grantham resident schools, indicate in the coupon the city of your choice and then mail the coupon to the School's home office in Hollywood, Calif. Free details will be mailed to you promptly.

GET your first class commercial F. C. C. LICENSE

To get ahead in electronics—first, you need the proper training; then, you need “proof” of your knowledge. Your first class commercial F. C. C. license is a “diploma” in communications electronics, awarded by the U. S. Government when you pass certain examinations. This diploma is recognized by employers. Grantham School of Electronics specializes in preparing you to *earn* this diploma.

Grantham training is offered in resident classes or by correspondence. Our **free** booklet gives complete details. If you are interested in preparing for your F. C. C. license, mail the coupon below to the School's **home office** at 1505 N. Western Ave., Hollywood 27, California—the address given in the coupon—and our free booklet will be mailed to you promptly. No charge—no obligation.

Get your First Class Commercial F. C. C. License by training at .

GRANTHAM SCHOOL OF ELECTRONICS

HOLLYWOOD

SEATTLE

KANSAS CITY

WASHINGTON

This booklet **FREE!**

This free booklet gives details of our training and explains what an F. C. C. license can do for your future. Send for your copy today.

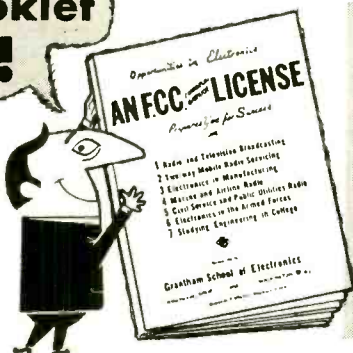

for **FREE** Booklet **CLIP COUPON** and mail in envelope or paste on postal card.

for **FREE** Booklet **CLIP COUPON** and mail in envelope or paste on postal card.



To: **GRANTHAM SCHOOL OF ELECTRONICS**
1505 N. Western Ave., Hollywood 27, Calif.

Please send me your free booklet telling how I can get my commercial F. C. C. license quickly. I understand there is no obligation and no salesman will call.

Name _____ Age _____

Address _____

City _____ State _____

I am interested in: Home Study, Kansas City classes, 14A
 Hollywood classes, Seattle classes, Washington classes



83 YX 929. Stereo Tape Record-Play Preamp Kit. \$79.95 (less case)

One of the many great Knight-Kit stereo component kits. Professional quality; superb performance with virtually any tape transport; separate dual-channel recording and playback preamps; permits tape monitoring, sound-on-sound and echo effects. Packed with quality features for every possible stereo and monophonic function...



83 YX 928. FM-AM Hi-Fi Tuner Kit. \$49.95

Typical Knight-Kit hi-fi value—incomparable at the price. With AFC, tuned RF stage on FM, multiplex jack. Straight FM tuner kit also available at \$38.95. For deluxe Stereo FM-AM and FM tuner kits, see the Allied catalog...



83 YX 927. 20-Watt Stereo Hi-Fi Amplifier Kit. \$39.95

Biggest bargain in quality Stereo hi-fi. Has special clutch-type dual-concentric level control; simplified control facilities; DC preamp filaments. Similarly styled 32-Watt Stereo Amplifier Kit with full frequency center channel available at a low, low \$59.95...



83 YU 934. Deluxe 70-Watt Stereo Hi-Fi Amplifier Kit. \$119.95

Super-power to drive any of today's speakers, a do-it-yourself stereo masterpiece, featuring: special "blend" control; full-range center channel; tape-source monitor; dual phasing switches; Stereo paralleling switch. For deluxe 40-watt Stereo amplifier at only \$76.95, and 60-watt Stereo amplifier, see the Allied catalog...

Simply

these and 59

knight
A PRODUCT

a pleasure to build...

The most satisfying do-it-yourself experience awaits you when you build a Knight-Kit! You'll marvel at the sheer ease of assembly, absolutely assured by exclusive "show-how" manuals, wall-sized picture diagrams, step-by-step do-and-check instructions, pre-cut wire, "visi-packed" parts and an engineering perfection that eliminates guesswork. You'll get perfect results. You'll enjoy with pride a true custom-built electronic product, professionally engineered and styled—the best you can own. And to top off your pleasure, you'll save substantially at the unbeatable Knight-Kit price...

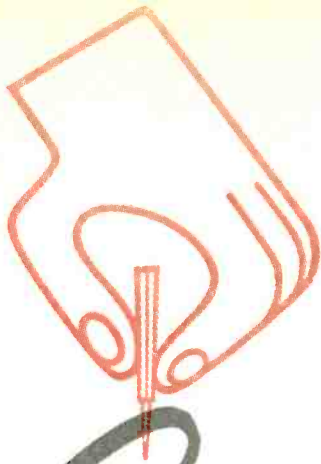

83 YX 712-2. Superhet Citizen's Band Transceiver Kit. \$79.95

Dual-conversion for highest sensitivity and selectivity; crystal-controlled operation on any 2 channels, plus manual tuning. Another Knight-Kit Citizen's Band Transceiver is available at an amazing low \$39.95—see the Allied catalog for full details...

Great!
other money-saving

-kits[®]

OF ALLIED RADIO

and you own the best

money back guarantee

Every Knight-Kit is unconditionally guaranteed to meet our published specifications for performance or your purchase price is refunded in full.

only \$2 down

It's easy to buy any Knight-Kit: only \$2 down on orders up to \$50; \$5 down up to \$200; \$10 down over \$200—up to 24 months to pay.

Featured

IN THIS VALUE-PACKED 1961
444-PAGE ALLIED CATALOG

Send coupon today for the 1961 Allied electronics catalog (the world's biggest), featuring the complete Knight-Kit line. See the best in electronic kits—save on *everything* in Electronics. Send for your **FREE** copy now!

sold exclusively by

ALLIED RADIO
pioneer in electronic kit development

our 40th year



also available
in Canada



83 YX 258. 4-Band "Span Master"® Receiver Kit. \$25.95

Fabulous performer for world-wide reception; thrilling shortwave adventures, plus fine Broadcast; band-switching, 540 KC to 30 MC; with cabinet. For additional receiver kits, radio-intercom, clock-radio, transistor radios, intercom systems, electronic labs and other great hobbyist Knight-Kits, see the Allied catalog...

83 Y 125. Electronic VTVM Kit. \$25.75

High sensitivity general-purpose VTVM; 11 meg input resistance; balanced-bridge circuit; 4½" meter. One of many fine instrument kits including 5" scopes, AC VTVM, tube checkers, signal tracer, audio generator, sweep generator, and others, described in detail in the Allied catalog...



send coupon today!

ALLIED RADIO, Dept. 8-A1
100 N. Western Ave., Chicago 80, Ill.

Send Free 1961 Allied Catalog No. 200

Name _____
PLEASE PRINT

Address _____

City _____ Zone _____ State _____



Latest Issue of
TUNG-SOL TIPS
tells you what you should know about
MULTIVIBRATOR CIRCUITS

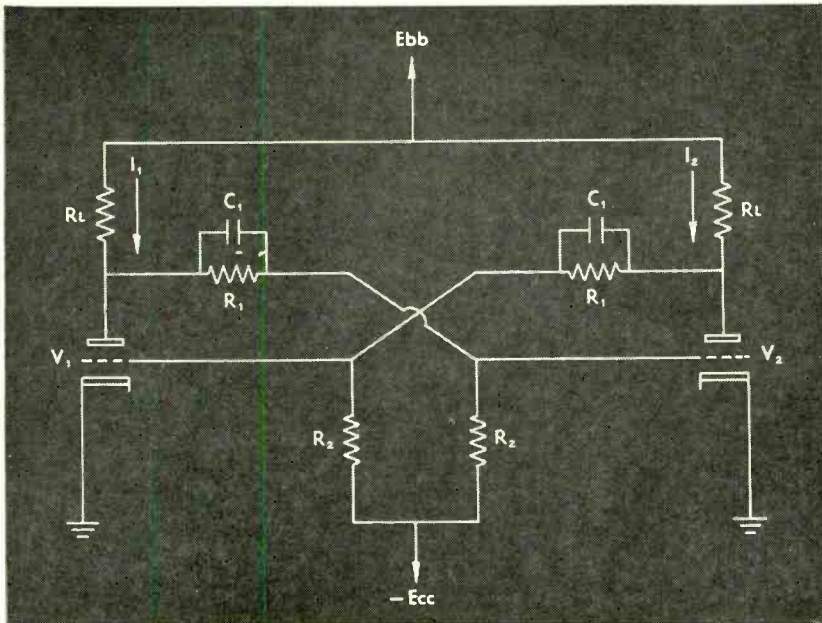

HERE is a typical multivibrator circuit. It's just one of several which perform many basic functions in computers and electronic counters and which find wide use as waveform generators. For the serviceman planning to expand his business to industrial equipment servicing, a thorough knowledge of these devices is a "must".

To give you this fundamental grounding in multivibrators, Tung-Sol has devoted the latest issue of its monthly series, *Tung-Sol Tips*, to a vigorous, down-to-earth treatment of these important circuits.

In issue #13, you'll find a comprehensive, fast-reading analysis of all the multivibrator circuits which you can expect to find in your industrial work. These include: the bistable multi, the cathode coupled binary, monostable; astable and high speed multivibrators.

The operation and application of each is carefully defined. Many circuit diagrams are included to round out your understanding.

There's more! The author has also included a special section that gives you maintenance and servicing clues that you can put to practical use immediately.

Don't miss out on this really important issue of *Tung-Sol Tips*. It's yours merely for the asking. Just drop into your Tung-Sol distributor. Or write directly. Tung-Sol Electric Inc., Newark 4, N. J.



SALES OFFICES: ATLANTA, GA.; COLUMBUS, OHIO; CULVER CITY, CALIF.; DALLAS, TEXAS; DENVER, COLO.; DETROIT, MICH.; IRVINGTON, N. J.; MELROSE PARK, ILL.; NEWARK, N. J.; PHILADELPHIA, PA.; SEATTLE, WASH. CANADA: TORONTO, ONT.

Correspondence



THE CONANT CHECKER

Editor:

My electrolytic capacitor checker story (October 1960 issue) is drawing some correspondence from those who want an extended range to measure larger capacitance values.

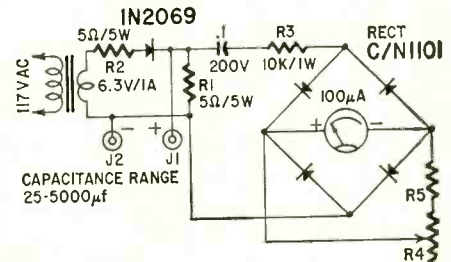

Therefore, I have devised the variation shown in the sketch so a high-capacitance range can be made readily available through switching.

With the values shown, I got a range of 25-5,000 μf which is good for all capacitors rated 6 volts or more.

Changing R1 to 2 ohms and reducing the value of R3 would give a range to 10,000 μf at down to 3 volts.

H. B. CONANT

Lincoln, Neb.

UNDERWATER STEREO

Dear Editor:

In your October 1960 issue you ran an item on underwater stereo, stating that this was the first time it was done. However, please note the enclosed clipping from the *Atlanta Journal & Constitution* of June 12, 1960, describing a system we had installed. [The newspaper story describes a stereo system installed in a pool. It uses two waterproofed speakers to fill the water with sound—sound that cannot be heard unless you are under the water.]

L. E. GLENN

Baker Audio Associates
 Atlanta 9, Ga.

[Our apologies. Guess this makes you first with underwater stereo with a date of June 12, 1960. Or is there someone else with a still earlier installation?—*Editor*]

DISAGREES WITH THE MAJOR

Dear Editor:

I just picked up my copy of the November 1960 issue at the newsstand and my eye caught the letter from Major William Price concerning the "Philadelphia Plan."

To me, this is just another round of crying by a few individuals who have set themselves up as service technicians

Here's The Offer No Other Radio-TV School DARES MAKE!

LEARN AT HOME in Spare Time!

YOU DO MANY PRACTICAL JOBS with the kits we send you. That's right, you PRACTICE what we TEACH! You build a Signal Generator, AC-DC Power Pack, and AC-DC Superheterodyne Radio Receiver and top quality 21 inch TV Set. EARN AS YOU LEARN with the famous RTS 30 Day Income Plan. Full instructions provided. NO HIGH SCHOOL DIPLOMA NECESSARY. This is a COMPLETE course which starts with basic subjects and gradually advances to Radio-TV. . . . ALL FOR A PRICE YOU CAN AFFORD!

*THE ONLY VERTICAL MULTI-CHASSIS 21" TV KIT OFFERED BY ANY RADIO-TV SCHOOL

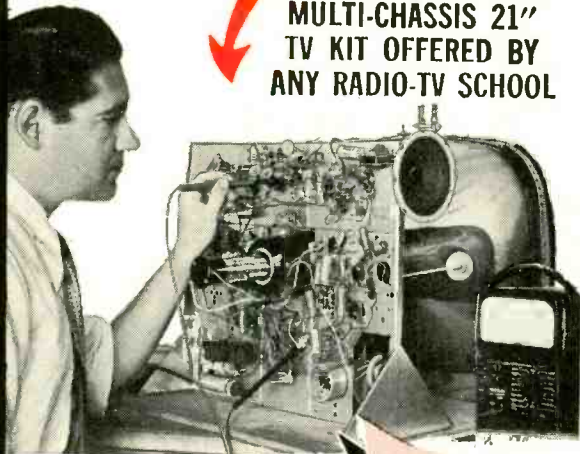

YOU BUILD THESE AND OTHER UNITS!

COMPLETE COLOR TV INSTRUCTION INCLUDED!



Each student is entitled to unlimited consultation service. All questions are answered promptly and completely by highly specialized instructors

*Tubes Excluded

RTS' Membership in The Association of Home Study Schools is your assurance of Reliability, Integrity and Quality of Training.

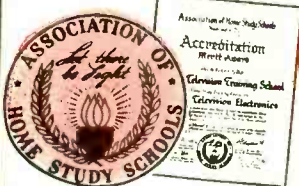

RADIO-TELEVISION TRAINING SCHOOL

815 E ROSECRANS AVENUE
LOS ANGELES 59, CALIFORNIA

L 101D

Est. 1922

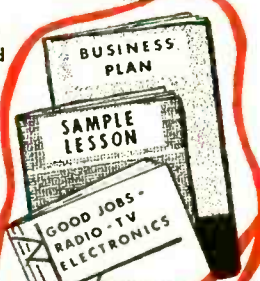

Rush Coupon for FREE FACTS!

RTS Will Train You at a Price You Can Afford and When You Are a Qualified Graduate Will Help You Open a Service Shop of Your Own and Supply You With Every Bit of Equipment You Need to Get Started - Plus an Inventory of Parts and Necessary Supplies.

ALL FINANCED WITHOUT INTEREST OR CARRYING CHARGES!!

You Also Receive . . . Advertising Help and Material, Shop Plans, Business Systems, Letterheads, Calling Cards and Much More!

Here's What Two of Many Business Plan Shop Owners Have to Say!

This business takes in between \$1500 and \$2000 a month. I've had to hire help to keep up with it.

CULLEN W. IRBY
Corpus Christi, Texas

The school lives up to its promises 100%. RTS does not lose interest in its students once they graduate.

HAROLD R. STANLAKE
Perry, Michigan

DON'T LOSE OUT — FIND OUT!

RADIO TELEVISION TRAINING SCHOOL, Dept. RE-11
815 E. Rosecrans Ave. Los Angeles 59, Calif.

Rush me full information by return mail. (Please Print)

NAME _____ AGE _____

STREET _____

CITY _____ ZONE _____ STATE _____

NO SALESMAN WILL CALL ON YOU!

UNMATCHED FOR CONVENIENCE . . .

DUAL HEAT SOLDERING GUN

FOR ONLY
\$7.95
LIST
Model 8200K



. . . and best of all, it's a

Weller®

Here from Weller, long time leader in the soldering field, is the most practical convenience feature ever offered in a soldering tool.

WELLER DUAL HEAT FEATURE saves time, gives greater convenience and greatly increases tip life. A touch of your finger on the Triggermatic control switches heat to high (125 watts) or low (90 watts) as your job requires. It adapts instantly to varying needs, and you use high heat only when necessary.

HIGH EFFICIENCY WELLERTIP utilizes copper for superior heat transfer and soldering efficiency, plus iron plating for durability. Flat cross-section design gives added strength and rigidity.

MODERN DESIGN with sturdy plastic housing that resists hard knocks. Compact "feel" and comfortable balance aid precision soldering. Like all other Weller guns, this new model features instant heat, and a spotlight illuminates your work.



KIT INCLUDED

In addition to the Dual Heat Soldering Gun you get:

- Nylon Flux Brush
- Soldering Aid for opening old joints, twisting wires
- All-purpose Solder

Other dual heat models available—\$12.95 and \$16.25 —up to 275 watts.

and have found that they are not technically capable of making a reasonable profit in the radio and TV service business.

Therefore, they have cried, "Organize, eliminate the part-timer, destroy service competition, then we can steal the public blind with our service charge." I do not mean to imply that the majority of our service technicians are not qualified. Most of them are! However, so are most of the part-timers. I work for Collins Radio's Microwave Div. and think nothing of having more than 7,000 tubes in one system.

But let's stick to TV service. I have been forced to limit my practice to old-age pensioners and those who have been out-and-out gypped by local "screwdriver mechanics." When I replace a tube or other part, it goes into a paper sack which my customer receives when he gets his set back. How many of you full-timers do this?

Part-timers have survived legal and verbal attacks. You can't get rid of us, so why not forget the Philadelphia plan and let us develop new ways to speed TV service. We have the time to experiment a little now and then. We can be a big help to you by taking on your dogs and low-profit jobs.

Let's not try to eliminate part-timers or full-timers. Let's all join together to eliminate dishonesty and incompetence in TV service. The Philadelphia plan is not the way to do it.

HAROLD E. YODER

Garland, Tex.

[Most technicians are not out to get rid of part-timers. They simply want the part-timer to compete on a fairer basis—in other words, pay taxes and know what he is doing. In any state that has a licensing law, part-timers are not prevented from becoming licensed technicians. The qualification for getting a license is based on technical knowledge and skill, not on how many hours a day you work as a TV repair technician.—Editor]

THE RIGHT CURE?

Dear Editor:

In the December, 1958, issue (page 116), Louis Sherman suggested a drastic modification to restore vertical amplitude on a Muntz model M32. The loss of deflection is obviously due to the failure of some other component in the vertical section, and altering the oscillator plate load by such a large amount to increase drive is only obscuring the real cause of the trouble.

Would it not be advisable to add an editorial comment regarding the practice of modifying the design of a circuit to cure a fault?

R. H. SHAW

Middlesex, England

[It certainly would be advisable. Circuit modifications to restore proper operation should only be made as a last resort—when no sign of any circuit defect can be located. For example, if the decrease in vertical deflection had been caused by a leaky capacitor and was compensated for by increasing drive, it would only be a matter of

WELLER ELECTRIC CORP. • 601 Stone's Crossing Rd., Easton, Pa.



OMNIDIRECTIONAL

ELECTRO-VOICE MODELS 636 AND 630 eliminate critical placement . . . assure remarkable fidelity. Omnidirectional from all points.

For truly uniform microphone response—for slim-trim case styling—for complete application versatility, the Electro-Voice Model 636 Dynamic is unsurpassed. Designed especially for public address and general purpose applications, the Model 636 blends easily, unobtrusively into PA stagings, eliminating placement problems and improving audience enjoyment. The baton design provides a convenient, easy-to-handle shape for hand carrying. This modern, streamlined model measures only $1\frac{1}{8}$ inches in diameter, yet provides output levels equal to microphones four times as large. *Other Features:* Exclusive E-V Acoustalloy diaphragm. Adaptable to either high or low impedance inputs; convenient ON-OFF switch for instant control; uniform response from 60 to 15,000 cps; wire mesh grille to minimize wind and breath blasts; tiltable through 90° arc toward sound source. List price (less stand). Satin Chromium Finish—\$72.50; Gold Finish—\$77.50.

Omnidirectional also describes the performance of the popular Electro-Voice Model 630 Dynamic Microphone. Designed by the same top acoustical engineering talent that developed the slim Model 636, this versatile microphone also provides optimum performance for an unusually wide range of professional, commercial, and personal applications. An exceptionally rugged instrument, the Model 630 may be mounted on a floor or desk stand or it may be hand held. List Price (less stand) \$52.50.

Complete specifications available upon request. For a trial demonstration of either of these fine, omnidirectional microphones, visit your Electro-Voice dealer—today.



MODEL 630

Electro-Voice[®]

Commercial Products Division
ELECTRO-VOICE, INC.
Dept. 1-E Buchanan, Michigan

Complete BASIC Electronic Training

(TELEVISION—RADIO—COMMUNICATIONS—INDUSTRIAL)

....written so you can understand it!
....and priced right!

These two big books bring you the most important training of all—because it is basic! They keep you from making the all too common mistake of trying to get ahead in Electronics without a clear and complete understanding of the fundamentals that make it "tick." Backed by this training, you'll read technical articles with new understanding. You'll approach technical problems without guesswork. And you'll be well prepared for whatever electronic specialization appeals to you most—television, radio, hi-fi, communications, electronics, service, technical industrial work and all the rest!

First, the big BASIC ELECTRICITY manual gives you a full working knowledge of the principles, components, circuits, equipment, instruments, measurements, etc., on which all Electronics is based. Then the BASIC ELECTRONICS manual teaches you just how these are applied.

Set-up diagrams, practical problem solutions, and almost 900 illustrations help make everything perfectly clear. Nothing is omitted or condensed. Complicated subjects are explained so clearly you can understand them—even without previous technical training.

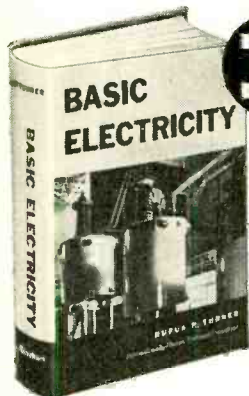

1

BASIC ELECTRICITY

Practical training that really helps you understand things!

The real key to success in Electronics is to get your complete background in *Electricity* FIRST. Then you'll begin substituting real "know how" for guesswork! That's why this 396-page guide to BASIC ELECTRICITY is invaluable to beginners—and equally helpful to more experienced men whose background in the all-essential electrical fundamentals is not entirely clear. This big manual with its more than 300 pictures, charts and diagrams is a down-to-earth guide to underlying principles, their practical uses, their problems and solutions. Includes: Currents; Circuits; Electro-magnetism; Phase Relations; Instrumentation; Measurements; Power Factor; Motors; Generators; Controls; Batteries; Tubes; Transistors; Amplifiers; Sound Reproduction and dozens of related subjects. Price only \$6.25 separately—or see Money-saving Offer in coupon.

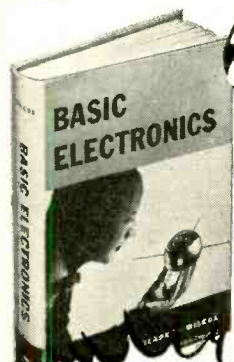

2

BASIC ELECTRONICS

The new book that makes complicated electronic subjects easy to learn!

Just out! BASIC ELECTRONICS manual with its 402 profusely illustrated pages brings you a full and complete understanding of the components, circuits, equipment and applications that represent the basic factors of practically everything with which you must deal in electronic work of any kind. Best of all, it's written so you can understand it! Over 550 illustrations explain practically all kinds of basic circuits, and their applications. Each topic begins with the simpler devices and progresses logically and clearly to the more complex. Topics include: Fundamentals; Tubes and Semiconductors; Sensory Devices; Load Devices; Basic Circuits; Rectifier Applications; Instantaneous, Timing and Sequence Controls; Amplifiers; Receivers; Oscillator Uses . . . and dozens more. A "must" training guide for those who really want to get ahead! Price only \$6.25 separately—but see money-saving offer.

10-DAY MONEY BACK GUARANTEE

SAVE
\$150!

Get both books for only \$11.00... have a complete BASIC training library at your fingertips!

Dept. RE-11 Technical Division,
HOLT, RINEHART and WINSTON, INC.
383 Madison Ave., New York 17, N.Y.

Send following manuals for 10-day FREE EXAMINATION. I will then promptly remit price indicated (plus postage) or return books postpaid and owe nothing.

BASIC ELECTRICITY (Price \$6.25) BASIC ELECTRONICS (Price \$6.25)

MONEY-SAVING COMBINATION. Send both of above manuals at only \$11.00 for the two. (You save \$1.50)

SAVE: Send money with order and we pay postage. Same 10-day return privilege with money promptly refunded.

Name _____

Address _____

City, Zone, State _____

OUTSIDE U.S.A.—Either book \$6.75, both for \$12. Cash with order but 10-day return privilege with money refunded.

time before the leakage increased enough to reduce the picture size once again.—Editor]

I LIKE REVERBERATION!

Dear Editor:

With reference to "And Now . . . Reverberation" on page 43 of the August issue, I've long felt that proper reverberation in stereo playback was at least as important as easily exploitable directional effects for an illusion of realism.

For the audiophile with an elaborate system it would be desirable, I believe, for the reverberated sound to be played back over separate amplifiers and speakers grouped down the length of the listening room on either walls or ceiling. Aeolian-Skinner of Boston did this for "dead" churches a few years ago, using a multiple-head tape delay system at 7½ ips. I've read of a system demonstrated by Phillips of Holland that was said to be most realistic. Then, too, Telefunken makes a system with magnetic heads placed around the rim of a rotating disk which is coated with a magnetic oxide. (To eliminate wear, the head is separated from the oxide an extremely fine distance.)

Most such tape systems are just too expensive for the audiophile, even one who has an elaborate system.

The problem is devising some means of achieving multiple time delays, feeding the delays simultaneously to auxiliary speakers to get the reverberation "off" the sound wall and back into the reverberation system at a lower level for proper die-away.

One major criticism directed against modern concert halls is that their reverberation period is too short and that they are too "bright"—that is, bass dies away at the same rate that treble does. A proper reverberation device should cause treble to die away at the "proper" greater rate than bass and at the same time must add no coloration to the reverberated sound by emphasizing certain frequencies in the mid-range as one would suspect a mechanical delay line might do.

Obviously, a prefabricated duplicate of Boston Symphony Hall available to the audiophile for a mere \$29.95 would be the best solution. But even in this era of plastics this seems a bit remote.

E. D. HOAGLAN

Omaha, Neb.

NO ANSWER

Dear Editor:

Slightly more than two months ago I answered a prominent computer manufacturer's advertisement that appeared in your magazine. This company advertised openings for field engineers. I sent a resume of my schooling and experience in electronics but to date the letter has not even been acknowledged. I had expected to receive at the very least a brief note telling me whether I possessed the necessary qualifications for such a position.

In questioning other job seekers I found a number of them had had the same such one-sided correspondence with similar companies.

Another outstanding product by the **HIDDEN 500*** who plan for your future:



TYPE TE LITTL-LYTIC[®] CAPACITORS



Transistors revolutionized the industry. And to make the most of their inherent advantages, they called for an entirely new group of components. Here, Sprague Research was the first to answer the call with the smallest truly reliable dry electrolytic made for transistor circuits—the Littl-Lytic. This reasonably priced capacitor is the most reliable subminiature you can buy for transistorized radios, hearing aids, wireless microphones, pocket wire recorders, and other miniature electronic equipment.

The remarkable reliability of Littl-Lytic is the result of a new manufacturing technique in which *all the terminal connections are welded*. Units are hermetically sealed and metal encased . . . *with no pressure joints . . . there are no "open circuits" with the passage of time*. Leakage current is extremely low as the result of the use of high purity foil and ultra-stable formation techniques. Sprague's catalog replacement ratings are the most comprehensive in the industry. They assure you of exact replacements to meet your day-to-day service requirements.

Littl-Lytic is a typical example of how Sprague Research keeps its products up-to-the-minute. Reliable components mean reliable service work—your business keeps pace with the electronic industry when you use Sprague.

*The "Hidden 500" are Sprague's 500 experienced researchers who staff the largest research organization in the electronic component industry and who back up the efforts of some 6,000 Sprague employees working in 14 manufacturing operations—four at North Adams, Mass.; Bennington and Barre, Vt.; Concord and Nashua, N.H.; Lansing, N.C.; Grafton, Wis.; Visalia, Calif.; two at Ponce, Puerto Rico; and Milan, Italy.

don't be vague . . . insist on

SPRAGUE[®]

world's largest capacitor manufacturer

An open letter to George W. Riggle

QUAM-NICHOLS Co
MANUFACTURERS OF
LOUDSPEAKERS AND TELEVISION
MARQUETTE ROAD AND PRAIRIE
CHICAGO 37, ILLINOIS

Mr. George W. Riggle
Ace Radio & Television
Service
Jacksonville, Florida



Dear Mr. Riggle:

I have just received a report from our laboratory on the Quam speaker you recently sent back to us.

You are absolutely right; this speaker, which you installed more than 25 years ago, is still in perfect operating condition.

As proud as we are to have this evidence of the quality of materials and workmanship of Quam speakers, we are prouder still that you took the time and trouble to tell us about it.

It's nice to know we have such good friends in the service profession—men like yourself, dedicated to quality, dedicated to thirty year, not thirty day, installations. It affirms our policy of manufacturing only the finest possible product.

Very Cordially,
QUAM-NICHOLS COMPANY

Helen S. Quam
Helen S. Quam

P.S. We, also, agree with you that an ad with a picture of this unit would speak "loud" for Quam.

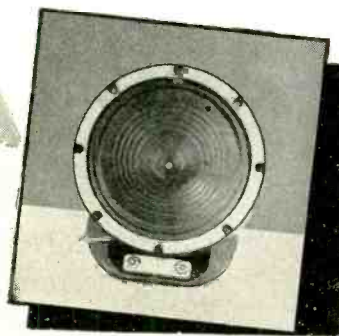

UNRETOUCHED PHOTOGRAPH

QUAM-NICHOLS COMPANY 238 East Marquette Road
Chicago, Illinois



What! me a writer?

Why not?—If you've got a pet project, design, circuit, or technique you'd like to tell the world about, RADIO-ELECTRONICS will consider publishing it. Write for an AUTHOR'S GUIDE.

FRED SHUNAMAN
Radio-Electronics
154 West 14th St., New York 11, N.Y.

I would like to pose a question to these companies. If you advertise for men, is it too much trouble to send a reply to those who took the time to read and answer your ad? I can see two good reasons for such a reply, the first being common courtesy. Second, the people in charge of hiring personnel are getting paid to do this job.

LAWRENCE H. MILLER
San Francisco, Calif.

[A few postcards would seem to be a justifiable investment in good will.
—Editor]

APPLICATION OF TECHNICAL KNOWLEDGE

Dear Editor:

I, like many other service technicians, have received adverse comments from time to time concerning charges for labor in a TV repair bill. To solve my problem I no longer show the word labor, yet I itemize everything that has gone into the set, including my time. In a separate item on the statement I show the following (which connotes, but never specifically mentions labor) —Application of Technical Knowledge —followed by the appropriate labor charge.

The customer's usual retort is, "I never thought of it before in that light."

DAN R. BROWNING
Decatur, Ga.

[An excellent approach. Nothing is hidden or falsified, yet the customer is impressed with the fact that labor, in this type of work, takes knowledge, hard learned. Any other readers have an approach of their own? We'd like to hear about it if you do.—Editor]

EFFECTS ON INVENTORS

Dear Editor:

While reading the June, 1960, issue, I came across the article "Another Forgotten Inventor." As the title suggests, this is not the first time something like this has occurred.

These happenings are not just a blow to the inventor, they affect the entire nation. First, the nation loses the usefulness of the invention (or the art is greatly delayed, as in this case). Secondly, and in my opinion by far the more important effect, this action greatly dampens the incentive of great minds. A man who has the ability to develop something like this can develop other things equally as great, or greater.

Then there is the effect that circumstances like this have on other inventors and their decisions. I personally know that this effect is far-reaching.

With incidents like this, it is no wonder that the press is frequently mentioning the scientific advancement of other nations.

THOMAS L. BARTHOLOMEW
Washington 10, D. C.

NOTE TO READERS

If you have built a RADIO-ELECTRONICS item—amplifier, test instrument, light detector, etc., let us know about it and include a photo or two. We will select and use the best ones in this column each month.—Editor

END

Learn RADIO, TELEVISION AND ELECTRONICS by Practicing at Home in Your Spare Time

At No Extra Cost you get specially developed Electronic Training Kits for practical experience. Shop and laboratory practice at home make learning easier, interesting, faster. You do not need a high school diploma or previous experience.

Increasing Demand for Trained Men

This is the Electronics age. Men with Electronic know-how are in demand. They enjoy high pay and growing opportunities for advancement. Satellites, Radar, Automation in Industry, Missiles, Rockets, Planes, Stereo, TV, Radio, Two

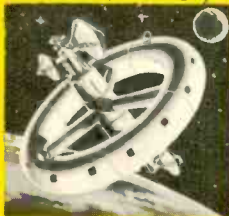

Way Communications for transportation are a few of the fantastic developments in the fast growing Electronics industry. If you are not completely satisfied with your work; if you are doubtful about your future, investigate Electronics.

High Pay, Prestige, Bright Future

What branch of Electronics interests you? Thousands of successful NRI graduates prove that NRI's learn-by-practice method is the way to success. You start in your chosen career way ahead of the man who only learns from books. You do not need to give up your job. You do not need to go away to school. You learn at home, get practical knowledge from training kits NRI provides.

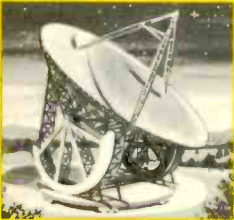

Train With the Leader

NRI is the world's oldest and largest home study Electronics school. You benefit from the experience NRI has gained from training men for 45 years. NRI offers you proven courses of home study in Electronics; Principles, Practices and Maintenance—Radio Television Communications—Radio Television Servicing.

Start Soon to Earn More

Soon after enrolling NRI shows you how to apply your knowledge to earn extra money doing Electronics repairs or servicing Radio and Television sets for friends and neighbors. Take the first step toward success now. Find out what NRI offers you. Mail the postage-free card. No obligation. Cost of NRI training is low. Monthly payment plan available. NATIONAL RADIO INSTITUTE, Washington 16, D.C.

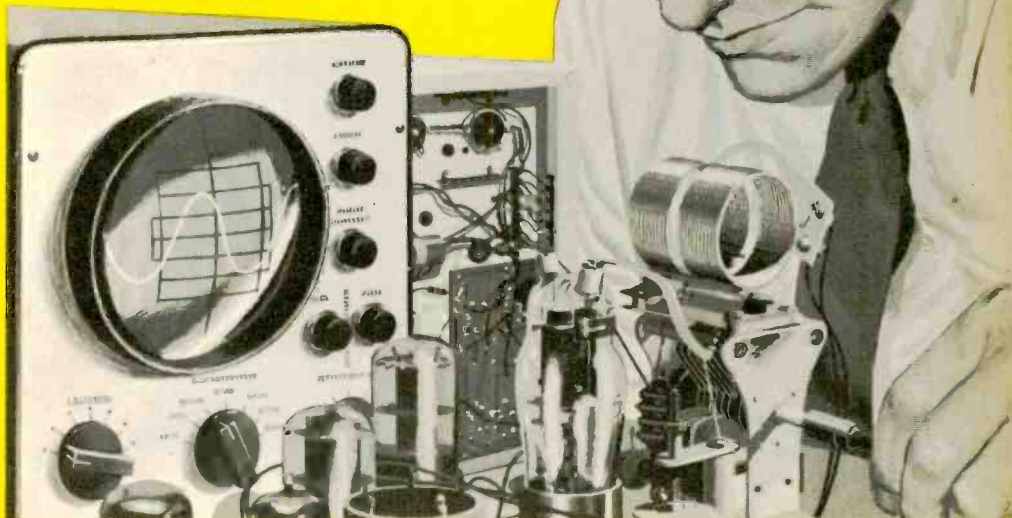

NRI Has Trained Thousands for Success



"I get over twice the salary I made before enrolling. NRI training gave me a thorough understanding." H. ATKINSON, Austin, Tex.

"I started with station CJIC, now in charge of sound effects for CBC. NRI opened doors to greater opportunity for me." F. TUDOR, Toronto, Ontario

"Averaged \$150 a month spare time before I graduated. Now have my own full time business and employ 2 men." F. W. COX, Hollywood, Cal.

NEW COURSE IN ELECTRONICS TURN PAGE

Cut Out and Mail—No Stamp Needed

64-PAGE CATALOG FREE

No Salesman will call. (Please PRINT) Z

Name _____ Age _____

Address _____

City _____ Zone _____ State _____

OLDEST & LARGEST HOME STUDY RADIO-TV SCHOOL
National Radio Institute
WASHINGTON 16, D. C.

ACCREDITED MEMBER NATIONAL HOME STUDY COUNCIL

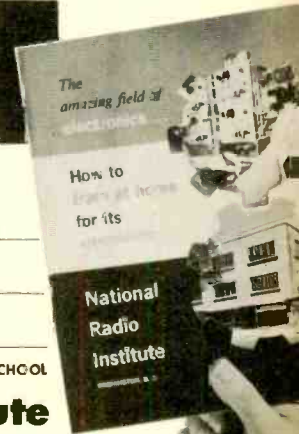



JOB COUNSELORS ADVISE LEARN ELECTRONICS

NEW Home Study Course in **ELECTRONICS** Principles-Practices-Maintenance **NOW READY**

This is the Electronic Age. Electronic equipment is already being used to count and control flow of liquids, solids, gases. Electronics is employed to search for oil, make surveys, control traffic, machine complex parts and in atomic installations. Military uses of Electronics are great and expanding rapidly. In business, Automation with Electronics plays an important part, prepares payrolls, calculates engineering formulas.

Learn More to Earn More

Now, to meet the growing demand for trained Electronic Technicians NRI has developed a comprehensive, complete course in Electronics Principles, Practices, Maintenance. This training stresses fundamentals. It is a course specially prepared for beginners and for Technicians. You get both theory and practical experience in an interesting, exciting way.

Ten Special Training Kits Give Practical Experience

You get practical experience with Thyatron Tube circuits, Multivibrators, build a D'Arsonval type Vacuum Tube Voltmeter (Kit 2); work and experiment with pentode tubes, selenium resistors, oscillators, transistors, magnetic amplifiers; and get practical experience in telemetry circuits as used in earth satellites, digital and analog computers (Kit 9).

NRI — Oldest and Largest School

Wishing for success won't bring success. You must act. Get FREE 64-page Catalog from America's oldest and largest home study Electronic-Radio-Television school. It gives facts, opportunities in Industrial and Military Electronics careers, also shows what you learn, tells about NRI's other courses in Radio Television Servicing and Radio Television Communications. Monthly payments plan. Mail Postage Free Card for 64-page Catalog.

NATIONAL RADIO INSTITUTE, Washington 16, D.C.



PRACTICE WITH
17" TV RECEIVER

PRACTICE WITH
LOW POWER TRANSMITTER

PRACTICE WITH ULTRA
HIGH FREQUENCY OSCILLATOR

SPECIAL TRAINING KITS NO EXTRA COST

PRACTICE WITH
D'ARSONVAL TYPE VOLTMETER

PRACTICE WITH
AC-DC RECEIVER

SEE OTHER SIDE

FIRST CLASS

Permit No. 20-R

(Sec. 34.9, P. L. & R.)

Washington, D.C.

BUSINESS REPLY CARD

No Postage Stamp Necessary if Mailed in the United States

POSTAGE WILL BE PAID BY

National Radio Institute

3939 Wisconsin Avenue

Washington 16, D.C.

**POSTAGE FREE CARD
MAIL NOW**

DESIGNED

AS YOU WOULD DESIGN IF YOU WERE AN ELECTRONICS ENGINEER...

Praised by the experts as Best Buys...

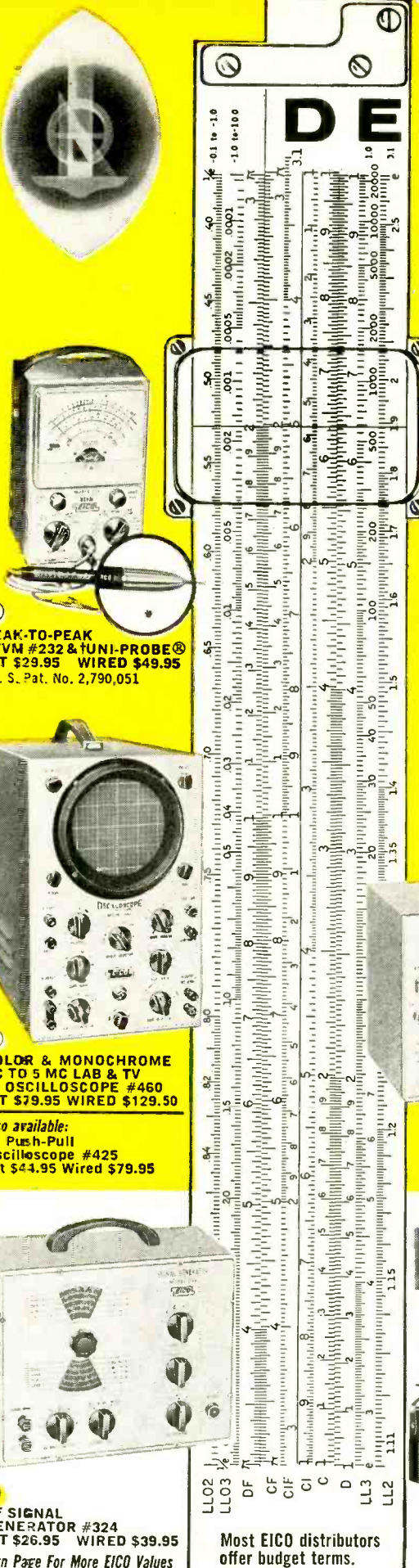

A PEAK-TO-PEAK VTVM #232 & UNI-PROBE® KIT \$29.95 WIRED \$49.95
U. S. Pat. No. 2,790,051



B COLOR & MONOCHROME DC TO 5 MC LAB & TV 5" OSCILLOSCOPE #460 KIT \$79.95 WIRED \$129.50

Also available:
5" Push-Pull Oscilloscope #425 Kit \$44.95 Wired \$79.95

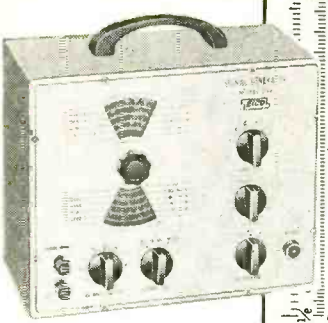

C RF SIGNAL GENERATOR #324 KIT \$26.95 WIRED \$39.95
Turn Page For More EICO Values

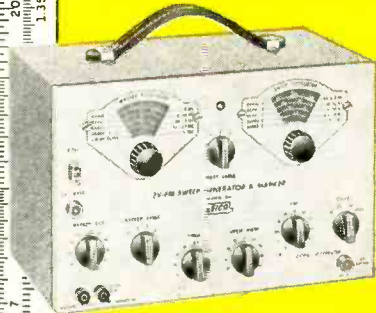

D TV-FM SWEEP GENERATOR & MARKER #368 KIT \$69.95 WIRED \$119.95

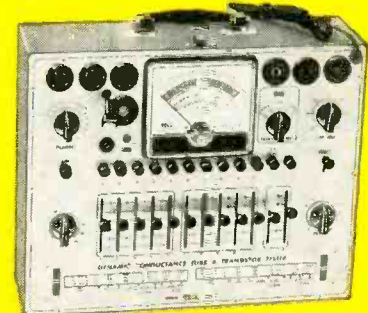

E DYNAMIC CONDUCTANCE TUBE & TRANSISTOR TESTER #666 KIT \$69.95 WIRED \$109.95
Complete with steel cover and handle



All Transistor Portable RA-6 Kit \$29.95 Wired \$49.95 less battery



Power & Bias Supply for Transistorized Eqpt. #1020 Kit \$19.95 Wired \$27.95



DeLuxe Multi-Signal Tracer #147 Kit \$24.95 Wired \$39.95



Tube Tester #625 Kit \$34.95 Wired \$49.95 Pix Tube Test Adapter \$4.50

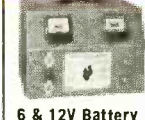

6 & 12V Battery Eliminator & Charger #1050 Kit \$29.95 Wired \$38.95 #1060 Kit \$38.95 Wired \$47.95

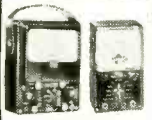

V-O-M #565 Kit \$24.95 Wired \$29.95 V-O-M #536 Kit \$12.90 Wired \$14.90



R-C Bridge & R-C-L Comparator #950B Kit \$19.95 Wired \$29.95

Most EICO distributors offer budget terms.

EICO 33-00 Northern Blvd., L. I. C. 1, N. Y. G-1
 Show me HOW TO SAVE 50% on Test Instruments
 Hi-Fi Ham Gear. Send me FREE Catalog, name of neighborhood dealer. Send free Short Course for Novice License.

Name.....
 Address.....
 City.....Zone.....State.....

© 1961 EICO 33-00 N Blvd., L. I. C. 1, N. Y. Add 5% in the West

EXPORT: Roburn Agencies, Inc., 431 Greenwich St., New York 13, N.Y.

*dedicated
to
perfection*

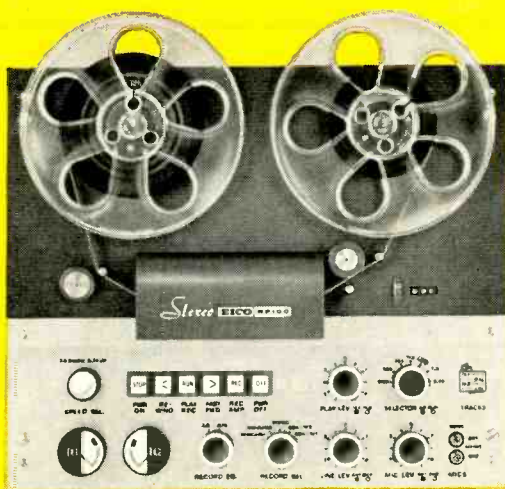

4-TRACK STEREO TAPE DECK

MODEL RP-100W

Completely assembled, wired and tested.
\$395.00

MODEL RP-100K

Semi-kit includes a completely assembled and tested transport, electronics in kit form.
\$289.95

Perfected 4-track stereo/mono recording, 4 & 2 track playback. True high fidelity transistor electronics, individual for record & playback, plus separate record & playback heads permitting off-the-tape monitor. 2 recording level meters, mixing, mic & level controls, switched sound-on-sound recording. Electrodynamically braked supply & take-up reel motors; hysteresis synchronous capstan motor. Individual solenoids for pinch-roller & tape lifters. All-electric, interlocked push-button transport control & interlocked safety "record" pushbutton. Precision tape guidance & sweep loading — no pressure pads. No slurring or tape bounce problems. Digital turns counter. Vertical or horizontal mounting. Modular plug-in construction. An original, exclusive EICO product designed & manufactured in U. S. A. (patents pending).

NEW MEDALIST LINE

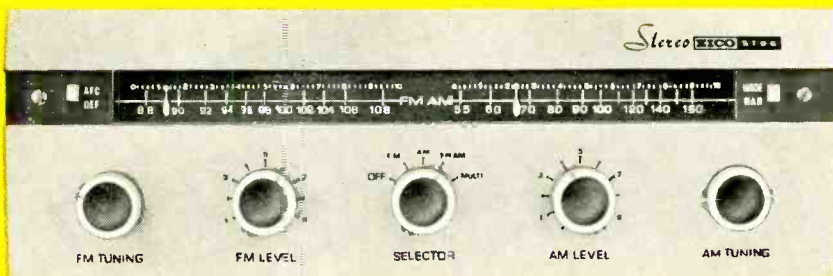

FM-AM STEREO TUNER ST96

Kit \$89.95 Includes Metal Cover and FET Wired \$129.95

FM and AM stereo tuners on one compact chassis. Easy-to-assemble: prewired, prealigned RF and IF stages for AM and FM. Exclusive precision prewired EYE-TRONIC® tuning on both AM and FM.

FM TUNER

Switched AFC (Automatic Frequency Control). Sensitivity: 1.5uv for 20db quieting. Frequency Response: 20-15,000 cps ± 1db.

AM TUNER

Switched "wide" and "narrow" bandpass. High Q filter eliminates 10 kc whistle. Sensitivity: 3uv for 1.0V output at 20db S/N ratio. Frequency Response: 20-9,000 cps ("wide"); 20-4,500 cps ("narrow").

OF EICO STEREO

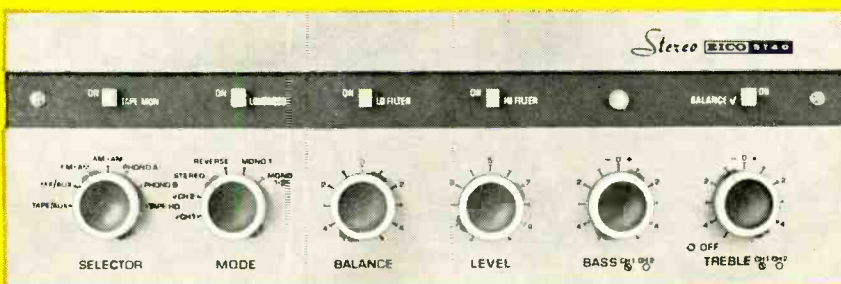

70-WATT INTEGRATED STEREO AMPLIFIER ST70

Kit \$94.95 Includes Metal Cover Wired \$144.95

40-WATT INTEGRATED STEREO AMPLIFIER ST40

Kit \$79.95 Includes Metal Cover Wired \$124.95

BOTH AMPLIFIERS: Complete stereo centers plus two excellent power amplifiers. Accept, control, and amplify signals from any stereo or mono source.

ST70: Cathode-coupled phase inverter circuitry preceded by a direct-coupled voltage amplifier. Harmonic Distortion: less than 1% from 25-20,000 cps within 1db of 70 watts. Frequency Response: ± 1/2 db 10-50,000 cps.

ST40: Highly stable Williamson-type power amplifiers. Harmonic Distortion: less than 1% from 40-20,000 cps within 1 db of 40 watts. Frequency Response: ± 1/2 db 12-25,000 cps.

Over 2 MILLION EICO instruments in use.
Most EICO Dealers offer budget terms.

There's an EICO for your every stereo/mono need. Send for FREE catalog.

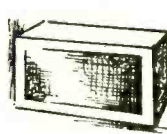
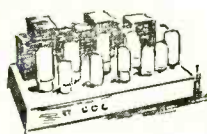

Listen to the EICO Hour, WABC-FM, N. Y. 95.5 MC, Mon.-Fri., 7:15-8 P.M. © 1961 by EICO, 33-00 N. Blvd., L. I. C. 1, N. Y.

EXPORT: Roburn Agencies, Inc., 431 Greenwich St., New York 13, N.Y.



EICO, 3300 N. Blvd., L.I.C. 1, N. Y. C-1
 Send free 32-page catalog & dealer's name
 Send new 36-page Guidebook to HI-FI for which I enclose 25¢ for postage & handling.
 Name
 Address
 City Zone State

Add 5% in West. Turn Page For More EICO Values.

“UNDERSEA RADAR”

. . . *Technically Impossible TV Programs Still Plague our Screens* . . .

LAST November one of our greatest television critics, John C. Crosby, who also is the nation's best-known syndicated radio and television columnist, voluntarily changed his 14-year-old job in disgust. His parting barb at TV: “This great medium of information and education is totally dedicated to utter vacuity.” He could also have added its other qualities: misinformation and general confusion.

As a recent glaring example of deliberate misinforming of the American public, let us cite a well known CBS network program, “Sea Hunt,” of Oct. 29 last, starring Lloyd Bridges as the intrepid skin diver. It is produced by Ziv-United Artists, Inc.

We wish to be charitable here in not divulging all of the most improbable and infantile story of this particular episode as concocted by its naïve scriptwriter. We are concerned only with the technical, or rather electronic, implausibilities of the lyrics—or should we call them liarics?

We follow Lloyd Bridges in fascination as he explores the bottom of the shallow sea, carrying in front of him—believe it or not—a *portable radar!* With bated breath we watch as the foxy Hollywoodpeckers switch to a closeup of the radar screen, showing us not the usual radar blips, mind you, but a screen filled with oblique, heavy white dotted lines! Bridges immediately knows that something terrible is going on, so he hotfoots it to the Navy in Washington, which of course has been busy underwater too, so nobody wants to talk to him, since they already have gotten wind of the undersea peril.

Back at his undersea radar hunt, he dives once more to find out what the enemy is up to. Sure enough, he soon locates a subsea “radar jammer” that breaches our “national defenses.” He immediately gives battle to the jammer's lone guard, who, stupid boy that he is, touches the jammer and is knocked out by radar! He drags him to his surface boat where a convenient Navy man in full high-brass uniform helps Bridges bring the unconscious enemy radar-keeper aboard.

So much for the silly and technically impossible, plot. No wonder the Navy would be interested in undersea radar, as who wouldn't be? Our Government, we feel certain, would gladly pay many mil-

lions of dollars for a workable undersea radar—the one thing needed to track enemy submarines. Today we must rely on sound waves, that is, our audio sonar gear, which is not very efficient and does not reach very far—less than 15 miles under water.*

Unfortunately, radar today is completely useless under water, particularly sea water. High-frequency radio waves do not travel under water, any more than light waves do. Within a very short distance in the water—particularly highly conductive salty sea water—radar waves are completely absorbed. Even *above* sea water, radar becomes almost useless over short distances. This is because of the so-called “return” of the high-frequency waves. Over long distances radar of course is very efficient.

With the bewildering array of new scientific wonders and inventions of the present century, the public finds that it simply cannot keep abreast of the myriad of new technical achievements.

Television—itself a seven-day wonder—is potentially one of the greatest all-time conveyers of information and education. Yet many of its irresponsible entrepreneurs unfortunately use TV as a commercial football to sell and exploit their sometimes shoddy wares first, being concerned with the programs secondarily and incidentally.

It would seem to be elementary that *every* program should be viséd for its technical accuracy and plausibility. Alas, Madison Avenue does not follow such a logical rule. The program is treated first and last as “entertainment”—and may the devil take the hindmost.

When a program such as the “Sea Hunt” under discussion is played “straight”, and deliberately misinforms millions of youngsters and grownups by televising technical impossibilities as facts, incalculable damage is done to the public. One cannot condemn the originators of such programs too severely for their irresponsibility when we realize that a modest \$50 bill would pay for the services of a competent technical adviser whose duty it would be to read the script *before* taping it. It would pay big dividends and TV would greatly gain in stature.—H.G.

*A new sonar just announced will reach 30 miles.

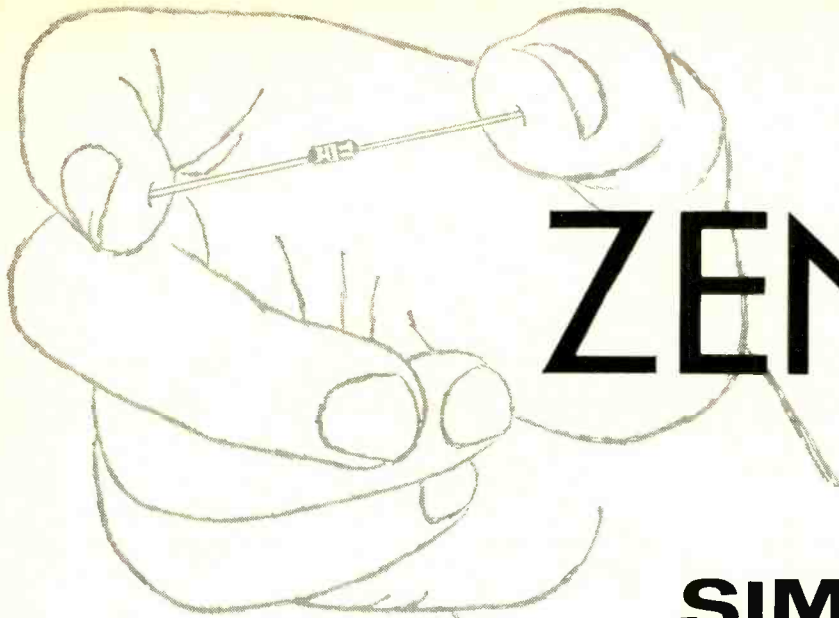

ZENER

DIODES

SIMPLIFIED

Zeners can do a number of jobs better than can any present device.

By DONALD L. STONER

ENGINEERS and service technicians are constantly being showered with new electronic components, many of which are too costly to ever appear in mass-produced equipment. One exception is the Zener diode. These interesting devices were introduced some time ago, but only recently have they become available to the budget-conscious experimenter.

This amazing member of the diode family is the solid-state equivalent of a voltage-regulator tube. But the Zener diode takes over where the V-R tube stops (about 75 volts) and is available in steps down to 3.9 volts.

In many respects, the Zener diode is also similar to the silicon rectifier cell. Such rectifiers are rated according to their current-handling ability and peak inverse voltage (or piv) the total or peak voltage appearing across the diode junction when it is reverse-biased (negative anode). If this peak rating is exceeded, the effects may be disastrous. If sufficient current flows to overload the diode in the reverse direction, a multiplication or avalanche takes place within it. Designed to handle only a few watts of power in the forward direction, it is subjected to many times its rating by the excessive reverse current. When this happens, the silicon wafer is overheated and the crystal structure destroys itself. A device damaged in this manner shows a low resistance in either direction and is no longer useful as a rectifier.

It is a common fallacy that exceeding the piv will ruin the diode. You can prove this is an "old wives' tale" and

incidentally make a handy piv checker by constructing the circuit in Fig. 1. The series resistance prevents excessive current flow in the silicon rectifier cell during reverse bias periods. The power transformer can be any type that will put out about 800 volts. The picture displayed on the oscilloscope is shown in the accompanying photograph. You can determine the piv by either calibrating the base line of the oscilloscope or measuring it on the meter. If the meter is used for measurements, it will be necessary to multiply the reading by 1.414 to determine the peak value.

Zener diodes

When forward-biased (positive anode), the Zener diode behaves much like the silicon rectifier cell just described. Once the barrier potential (0.6 volt approximately) has been overcome, the junction resistance drops to a low value and the diode conducts large amounts of current. In the reverse-bias direction (negative anode), only a tiny amount of current can flow. However, as the reverse voltage is increased, a point will be reached where avalanche or breakdown occurs. When avalanche breakdown is reached, the normally high back resistance drops to a low value and the junction current is limited by the circuit resistance. As the voltage is increased beyond the breakdown point, the diode current increases proportionately but the junction voltage remains essentially constant as shown

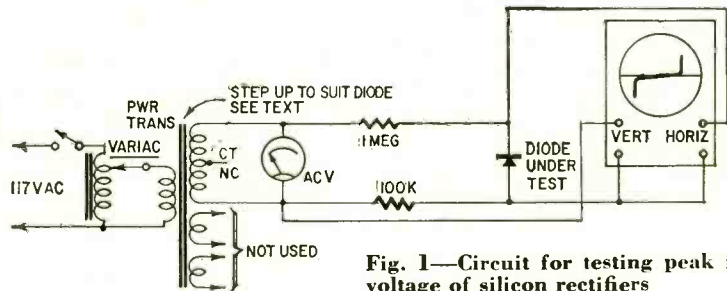
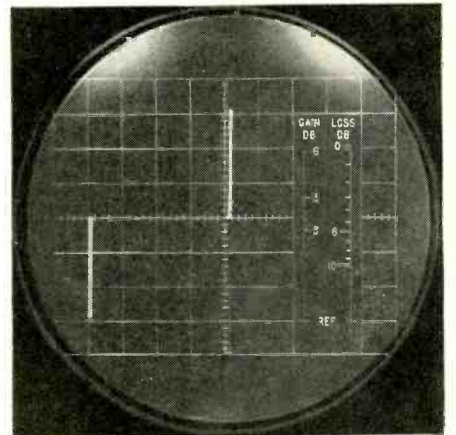

Fig. 1—Circuit for testing peak inverse voltage of silicon rectifiers



Typical Zener oscillogram for the equipment shown in Fig. 1.

in Fig. 2. Although we might say that the piv has been "exceeded," the diode is made large enough to dissipate the generated heat without damaging the junction.

Let's see how this effect can be used in a practical application. Fig. 3 shows a common method of connecting a Zener diode in a regulator circuit. The diode, in shunt with the load, draws current through resistor R, which is in series with the load. The total current through R is the sum of the Zener and load currents. If the unregulated input voltage increases, the current through both the Zener element and the load will increase. Simultaneously, however, the

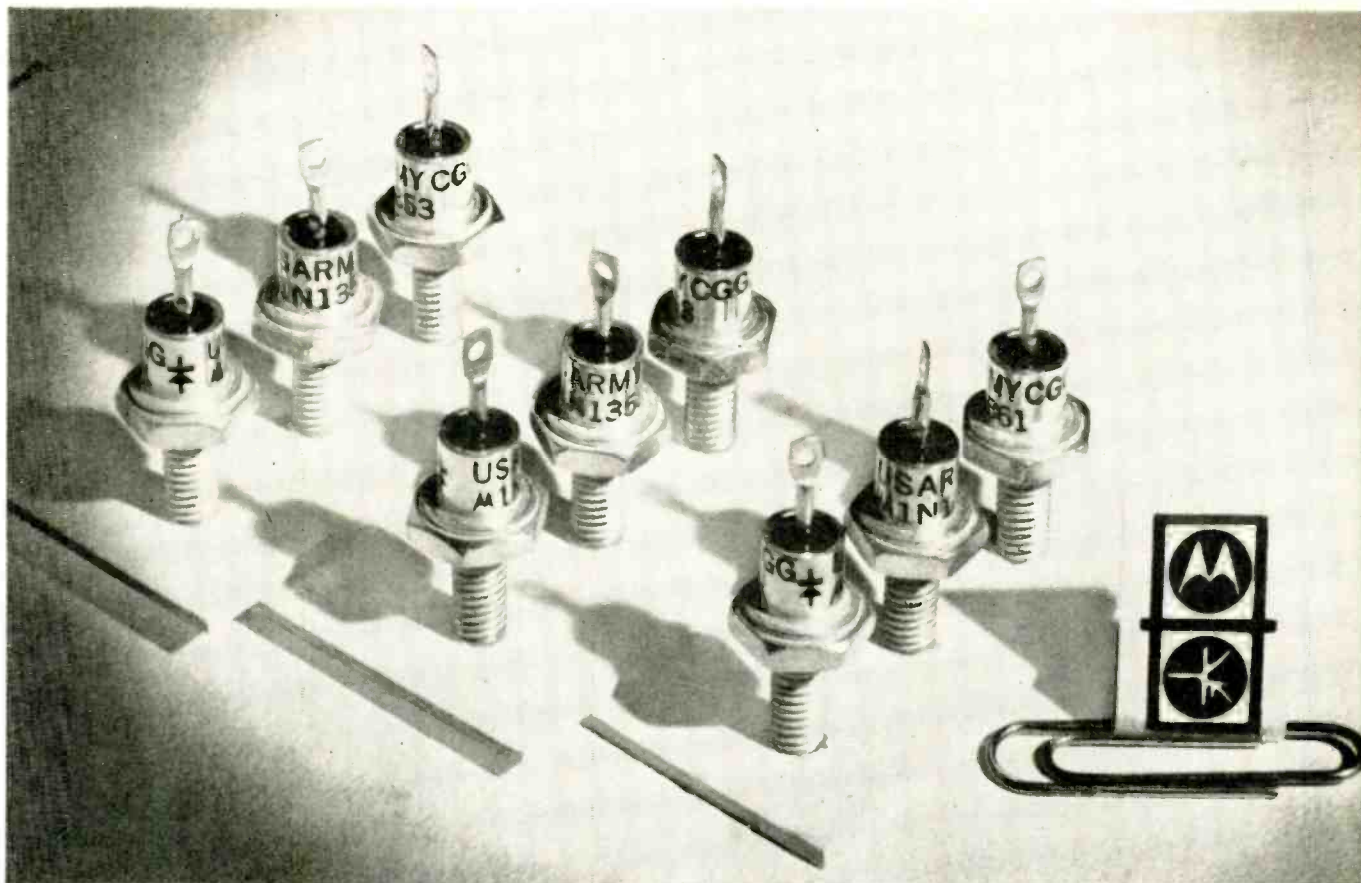

Motorola

Zener diodes for military uses solve many electronic design problems.

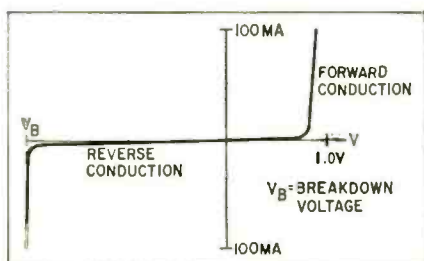

Fig. 2—Current and voltage characteristics of typical Zener diode regulator.

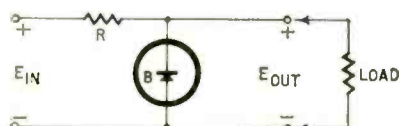

Fig. 3—Basic Zener diode regulator...

diode resistance decreases and the junction current increases, thereby adjusting the voltage drop across resistor R. Load variations have a similar effect on the diode regulator. As the load current increases, or decreases, the Zener shunt element will draw less or more current respectively. The net result is substantially a constant output voltage across the load.

The ability to regulate voltage or load changes is determined by the temperature coefficient and the dynamic impedance of the diode. A change in junction temperature can shift the diode operating point. The dynamic impedance is something like a bleeder resistor connected across a power supply. The lower the dynamic resistance,

the better the regulation. Temperature affects the Zener diode least in units around 5.6 volts. The dynamic impedance is reduced in larger diode sizes.

The only unknown in Fig. 3 is the correct value for resistor R. The value can be determined experimentally by substituting a rheostat for R and setting it so the Zener diode draws 20% of its maximum current rating (the customary operating point for a Zener diode).

The exact value can be calculated more accurately by using the formula:

$$R = \frac{E_{in} - E_z}{I_z + I_L}$$

To apply this formula, let's work out a typical Zener regulation problem. Assume you have a transistorized variable-frequency oscillator which operates in an automobile and must be regulated. The oscillator draws only 10 ma; thus even the smallest Zener units will be usable. We know that oscillator operation is satisfactory with a 9-volt battery. Therefore a Zener unit near this voltage is selected. A short consultation with the semiconductor catalog shows that an 8.2-volt 750-milliwatt, 1N1511, made by International Rectifier Corp., should do the job nicely.

Once the diode ratings are known, we can calculate the value of R. The automobile battery (E_{in}) will be approximately 14 volts (maximum) and E_z is 8.2 volts. The maximum Zener current (always given in the diode characteristics) is 90 ma, and therefore the normal operating point would be 18 ma (see above). All the numbers

required to fill in the formula are now known and it solves like this:

$$R = \frac{14 - 8.2}{.018 + .01}$$

$$R = 207 \text{ ohms}$$

Either a 200- or a 220-ohm resistor may be used for R and the Zener current will be slightly above or below the nominal operating point, but well within the diode ratings.

The wattage of R can be determined easily, since we know 5.8 volts will be dropped across it and 28 ma, will flow through it. Multiplying these figures shows that a 1/2-watt resistor is more than adequate.

The Zener diode is also useful in ac regulator circuits. In this application, it is necessary to connect two units "back to back." Remember, earlier it was stated that when forward-biased the diode would conduct much the same as a silicon rectifier cell. Since this is the case, the diode would appear as a short circuit across the load during positive alterations. The design considerations for ac are somewhat more complex than dc due to the waveform. Interested readers may peruse the subject in the *Zener Diode Handbook*.¹

Reference elements

A reference element is a group of Zener diodes with ultra-stable voltage regulation over wide temperature ranges. It is useful in computers, ultra-stable power supplies or in any application that requires the accuracy of a standard cell.

One of the most popular reference elements is the 1N430 diode. It is found

in military and quality commercial equipment. Inside the 1N430 you would find three series-connected Zener diodes, one operating in the reverse direction and having a *positive* temperature coefficient. The other two diodes are forward-biased and have a *negative* coefficient. The matching technique results in a near-perfect cancellation of voltage drift caused by temperature changes. The 1N430 specifications state that it will hold the reference voltage within $\pm .001\%$ per degree C over a range of -55° to $+100^\circ\text{C}$. Thus the reference voltage will not vary more than $\pm .0063$ volt (6.3 mv) over the operating range.

When supplied with a suitably regulated source of voltage, the 1N430 is usable as a secondary standard cell for meter and test equipment calibration. A circuit with near-perfect voltage stability is shown in Fig. 4. In industrial

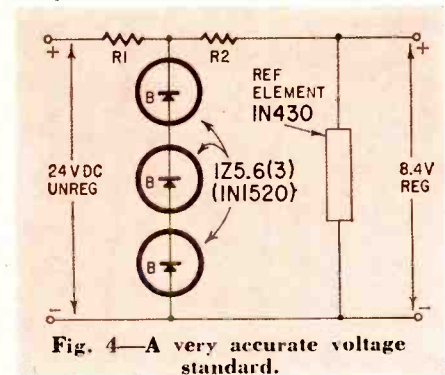

Fig. 4—A very accurate voltage standard.

equipment, where the temperature seldom exceeds $+55^\circ\text{C}$ (130°F), a stability of at least $\pm .0005\%/^\circ\text{C}$ could be expected!

Regulated power supplies

A Zener diode may be used as the reference in regulated power supplies. In this application the output voltage is compared to the Zener voltage and corrections are made if necessary.

One of the simplest circuits is shown in Fig. 5. The Zener diode determines the base bias in the emitter-follower transistor stage. If the load voltage decreases, the bias between emitter and

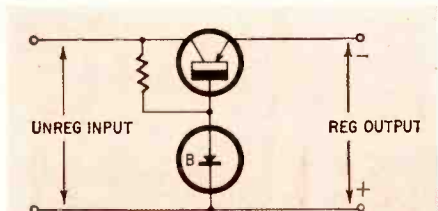

Fig. 5—Simple regulated power supply.

base is increased. This increases conduction in the transistor and returns the load voltage to its nominal value. Approximately one-tenth of the load current flows through the Zener diode. Thus a 1-watt diode and transistor could be used to replace a 10-watt Zener diode.

Although Zener diodes are not usually associated with high-voltage supplies, they may be used with transistors that have a high collector-to-emitter breakdown rating. Such a transistor

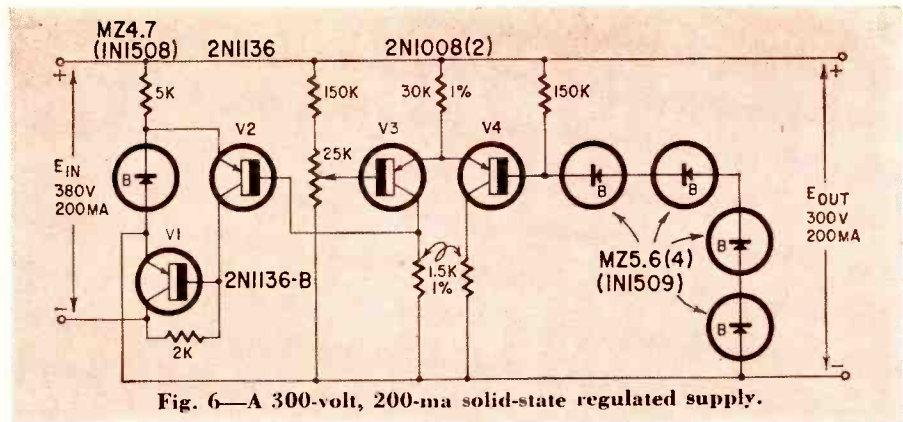

Fig. 6—A 300-volt, 200-ma solid-state regulated supply.

is the Bendix 2N1136-B, which has an E_{CB} of 80 volts and 60 watts dissipation. This transistor is used as the series element in the negative lead of a high-voltage regulated supply shown in Fig. 6. The difference between the input and output voltage is 80 volts with minimum load conditions. At the 200-ma maximum power supply rating, the transistor dissipates something less than 16 watts. In operation, an increase in the load current causes a decrease in the bias of V2 through the parallel-emitter pair (V3, V4). The action of V2, in turn, increases the bias on V1, decreasing its resistance and thereby returning the output voltage to its nominal value. A decrease in load current reverses the action, maintaining the output voltage at its correct value.

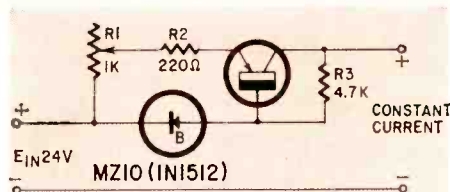

Fig. 7—Constant-current regulated supply. Values shown are for 10 ma maximum load current.

Zener diodes are also used in *constant-current* power supplies. Like constant-voltage supplies, current regulators can become highly complex. A simple circuit is shown in Fig. 7 and is optimized for 10 ma. It is handy when working with low-dissipation transistors. If the transistor should become overbiased or enter the thermal runaway region, this supply will prevent the collector current from exceeding 10 ma.

In this configuration two circuit paths exist. One is through the regular diode in series with the bias resistor. Current also flows through R1, R2 and the transistor. Any change in the current through R3 causes a change in base bias. The transistor, in turn, changes resistance to correct the current flow. The net result is that for every change in the R3 path there is an equal and opposite change in the transistor junction resistance.

Other applications

Although we have been speaking of Zener diodes in power-regulation applications, they actually have dozens of other uses. For example, think of the

Zener diode as a "special" resistor which always has a fixed voltage drop across it. If a Zener diode is inserted in the cathode circuit of a push-pull audio amplifier or modulator, as in Fig. 8, it will develop a fixed bias and establish a "rock-solid" operating point. (No bypass capacitor is needed, since the diode's impedance is very low.) This may not be particularly important in class-A and -AB1 amplifiers but the scheme is very useful in class-B circuits where the cathode current varies as much as 10 to 1. Even with such wide variations, the bias will remain at a fixed value.

The Zener diode in the cathode is also useful in class-C amplifiers. This type of amplifier usually receives its bias from signal rectification and grid current. If the source of signal fails the tube is protected in some manner, its dissipation will be exceeded and it will be destroyed in a short time.

If a tube with a plate dissipation of 100 watts were to be protected (as an example), a Zener diode could be used for protective bias. It is only necessary to determine the amount of bias needed to hold down the dissipation at a given plate voltage. This

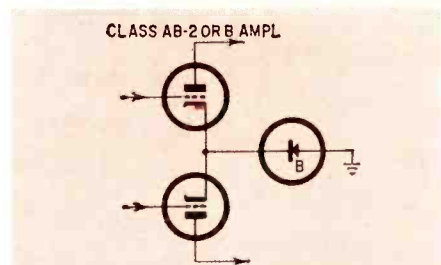

Fig. 8—Zener-diode biased audio stage.

figure may be easily determined from the tube characteristic curves. The Zener diode may also be used in the emitter circuit of a transistor to establish a stable operating point.

The Zener diode may not look like a coupling capacitor, but it can be used for one. Let's say you are cascading two common-emitter amplifier stages. If a Zener diode with a breakdown rating equal to the driver-stage collector voltage is used, a small current will be passed to bias the driven stage. Changes in collector voltage will change the bias on the driven stage directly. In effect, you have a dc amplifier with-



International Rectifier USN-1N430 silicon reference element.



Miniature voltage reference pack contains all components shown in Fig. 4.

out complex power-supply and voltage-divider connections. In addition, the diode has no reactance and therefore cannot affect frequency response.

Earlier it was stated that two diodes connected "back to back" would regulate both halves of an ac cycle. An examination of the waveform will show that the peaks are clipped to reduce the rms voltage. This process also increases the average level, which brings to mind an application as an audio speech clipper. Such a circuit is shown in Fig. 9. The effectiveness or "talk power" of a radio-telephone transmitter can be greatly increased by using a peak or speech clipper to raise the average modulation level. The energy content is increased, but the transmitter is not modulated beyond 100%.

The speech amplifier, part of which is shown in Fig. 9, develops approximately 30 volts of audio from a dynamic microphone. A small portion of this signal is applied to a pair of Zener diodes which clip any signal peak exceeding 3.9 volts. The harmonics produced by the clipping action are attenuated by the low-pass filter, consisting of L1, C1 and C2. The desired amount of audio signal is fed to the modulator by adjustment of R2.

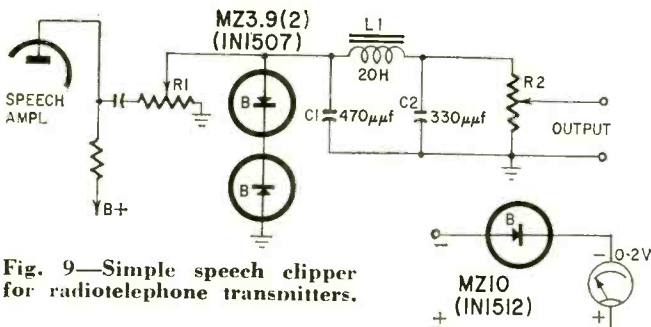

Fig. 9—Simple speech clipper for radiotelephone transmitters.

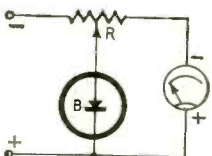

Fig. 10—Zener diode as simple meter protector.

The clipper need not be removed from the equipment to eliminate its effect on the voice energy. Simply turn R2 to its maximum clockwise position and control the audio level with R1. The Zener voltage will not be exceeded and clipping cannot occur. The amount of clipping can be regulated by reducing the setting of R2 and advancing R1.

Zener diodes are also useful in protection circuits to prevent damage due to arcing or transients. For example, have you ever connected a battery across an inductance, and then received a shock when one lead was removed? Even though the battery cannot store enough potential to shock you, the back emf due to the collapsing field of the coil will develop several hundred volts.

This effect is particularly troublesome when transistors are used to drive relays. When the transistor ceases to conduct, the back emf from the coil may be strong enough to punch through the transistor junction, thereby destroying it. A 3.9-volt Zener diode connected across the relay coil will conduct whenever that voltage is exceeded, thereby protecting the transistor.

The same problem, in a slightly different form, exists in transistorized power converters and class-B ampli-

fiers. Even though the transistors used in this type of equipment are rated for many times the supply voltage, they often go bad due to shorted or punched-through transistors. Auxiliary equipment used on the same battery lines may feed transients (due to back emf, as above) into the equipment. Again, Zener diodes connected between collector and emitter will provide complete transient protection.

Meter movements are also easily damaged due to overload. Fig. 10 shows the circuit for a voltmeter which cannot be damaged, even if you try! The resistance of the potentiometer (R) is selected to make the basic milliammeter read the right voltage at full scale. The Zener diode, which may be any convenient size, is connected to the arm. To set up the instrument, full voltage is applied to the input, making the meter read full scale. Then the potentiometer is adjusted until the meter indication just starts to drop. Now if the input voltage is increased further (which would normally pin the meter), the pointer will move up slightly, then come to a halt as the Zener diode conducts. Naturally readings below full scale will not permit the diode to conduct.

Speaking of meters, the Zener diode is also useful as a meter-scale expander. Let's say you need a meter which will accurately indicate 13 volts, for automobile regulator adjustment. If a 12-volt Zener diode is connected in series with a 2-volt dc meter, as shown in Fig. 11, it will show 12.0 volts at zero on the scale and 14 volts where 2 volts would normally be read.

Zener diodes possess many advantages over other forms of regulation devices. They are mechanically and electrically rugged and do not have the shelf life problems of batteries. Their low cost (50 cents and up) make them attractive to both the engineer and experimenter. END

REFERENCES

- 1International Rectifier Corp. Zener Diode Handbook.
- 2Bendix Aviation, Semiconductor Div., application report.

Fig. 11—This meter expander suppresses the low end readings completely. Values shown are for a 12- to 14-volt meter.



Zeniack, a 10-watt Zener diode substitution box made by International Rectifier.

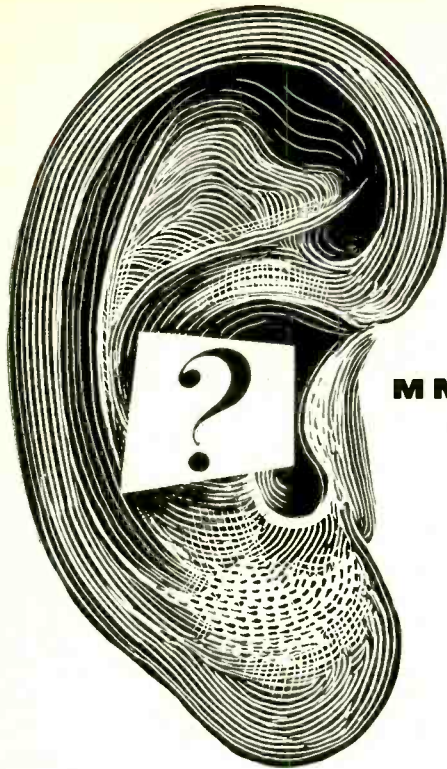

PUZZLED

MMMMMMMMMMMMMMMMMMMM

ABOUT HUM?

There are several causes and cures for induced hum in audio systems

By **NORMAN H. CROWHURST**

PERIODICALLY someone calls or writes in about a hum problem. By now hum is a familiar story to many of us, but it can be very puzzling the first time you run into it. Each piece of equipment is OK by itself but, when you assemble the system, a real lulu of a hum comes out of nowhere.

The real secret to tracing it rests in understanding the basic ways in which hum—or any other spurious induction, sometimes it's not hum but noise, pickup of a local AM station or something—can be induced.

Both components and connecting leads need protection against hum, in a form usually called shielding. And this is where one source of confusion arises. The requirements for shielding against different kinds of induction are quite different.

Induction can be magnetic, electro-magnetic or electric. (The latter is commonly called electrostatic, but this is an obvious misnomer when you think about it. If the electric charge were static, it would not bother you. It's the changing charges that induce trouble.) Each requires its own treatment.

Magnetic induction

Magnetic induction comes from the magnetic cores of power and audio transformers, filter chokes and motors. It induces spurious "signal" in a magnetic component—phonograph pickup, input transformer or tape playback head. This induction may become apparent only when the system is assembled and the offending part(s) brought into proximity—maybe the power transformer and the phono pickup, for example.

This induction can often be minimized by careful orientation—mounting

the components so the magnetic field is neutral at the point of pickup. But this is possible only if both components are stationary. A phono pickup has to move across the record and so cannot be at a magnetic-field neutral point at all times.

The alternative is magnetic shielding, either of the pickup or the radiating component, or both. Magnetic shielding material (such as Mumetal) is very expensive and not effective against very strong fields. So it is not practical to shield a large power transformer. Instead, its magnetic radiation can be considerably reduced by operating at a lower magnetic flux density. This is done by having more turns on all windings (primary and secondaries). Naturally, this means using a transformer wound specifically for the purpose. This is not something that can be done with an existing transformer.

Using an aluminum chassis instead of a steel one is another help in reducing magnetic hum. Since steel is a magnetic material, it carries the leakage flux, causing more trouble. An aluminum (or any other nonmagnetic) chassis doesn't "help" the hum radiation in this way.

It is always good practice to keep low-level input circuits (of any impedance) well away from power transformers and other hum-radiating components. This is usually taken care of in chassis layout, but it can be forgotten when assembling a system. Sometimes low-level wiring is run round the inside of a cabinet, close to the power transformer on a chassis, forgetting the power transformer is there.

Magnetic shielding on the pickup or playback head will quite effectively reduce hum pickup *that is low to begin with* (Fig. 1). The mistake is some-

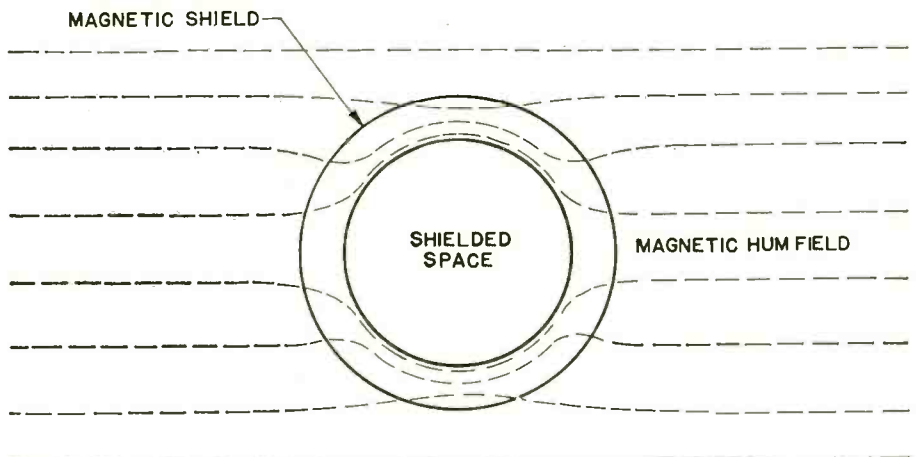

Fig. 1—Lines of magnetic force will not penetrate a magnetic shield providing that the field is not too intense.

times made of thinking that, since a shield is 50 or 90 db (or whatever figure is given) effective, the hum *must* disappear. But these values usually depend on a hum that is small initially (in terms of magnetic flux). That is why it is wise to use an aluminum chassis and keep the components well spaced.

Very often, too, the hum-reduction figure quoted for a shield was obtained in a symmetrical test field. Practical hum fields are *not* symmetrical and a shield that gives 50 db reduction in a test field may produce less than 20 db reduction in practical operation. (Some in fact make the hum worse!)

Electromagnetic induction is the bane of low-level *low-impedance* circuits. It can best be thought of as a *current* induction, although academically this is not accurate. Use of balanced lines (ungrounded or with a center-tap ground) was the classic remedy.

A low-impedance circuit needs a low-resistance "return" path. The secret of eliminating the *effects* of this induction lies in making sure that any induction is equal in both connections. The induced signals neutralize or cancel each other. A coaxial conductor or a tightly twisted one assures this. A concentric (coaxial) cable must have a high-conductivity outer sleeve making very good contact between its strands. The best cables use a tight, tinned copper braid or twist with inert insulation (insulation that will not oxidize or corrode). The outside insulation must, of course, prevent the outer conducting sleeve from accidentally contacting other circuits.

There *must* be only one ground connection to such a low-impedance connector. In a moving-coil pickup, for example, the coil circuit should be grounded at only one point and a ground for its case or pickup must be run separately. This is to avoid having any ground current flow through the low-level low-impedance circuit, causing unwanted induction.

Electromagnetic induction can cause a small hum voltage to be developed across a pickup coil, as in Fig. 2-a. This can be stepped up by the input transformer to a new value which may be 40 times as high as the original voltage. It can usually be minimized by using a high-impedance pickup (or microphone)

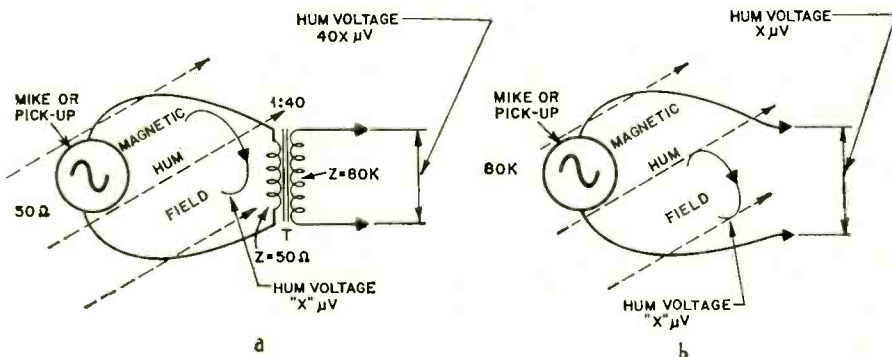

Fig. 2-a—The induced hum voltage is stepped up by T to 40 times its original value; b—when a high-impedance pickup is used, transformer T and its unwanted effects are eliminated.

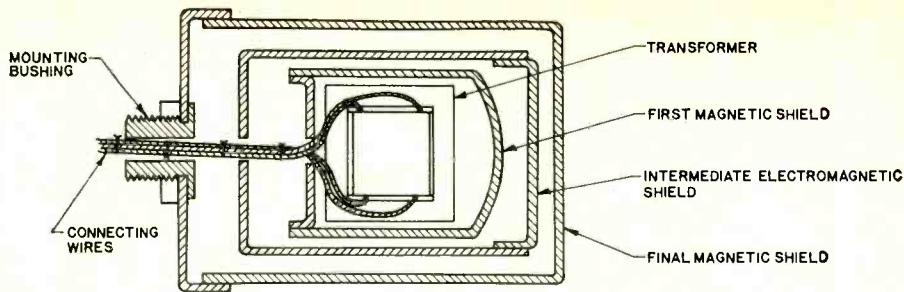

Fig. 3—In some instances, a combination of magnetic and electromagnetic shields must be used.

so that no transformer is required (Fig. 2-b).

"Electrostatic" effects

Electric (electrostatic) induction becomes more troublesome with higher circuit impedances. It radiates from high-voltage circuits. The remedy is somewhat simpler than for the other forms—an interposed, grounded shield. For medium-impedance circuits, requiring protection against both electromagnetic and electric induction, a twin twisted and shielded connector is best.

The twin twisting takes care of possible electromagnetic induction. Few shieldings are adequate for this, unless they are used as part of a concentric cable. Then the shielding, which is connected to ground at one end only, takes care of the electric induction.

So the best cable depends on circuit impedance and the kind of induction to which the circuit is liable. But entire circuits, such as filters, sometimes need shielding to keep out unwanted pickup too. For this there are the same three forms of shielding. As well as being effective against different forms of induction, they are effective over characteristic frequency ranges.

Magnetic shields

A magnetic shield (using Mumetal or other special magnetic material) must have high initial permeability, with very low hysteresis or eddy losses. This combination of requirements means that there is an optimum thickness. If more shielding is required, several concentric shields are better than one thick one.

Even with the best possible material (Mumetal or Hy-mu 80), a magnetic shield is limited to fairly low-flux-density magnetic inductions, is most effective at lower frequencies (not more than 200 to 300 cycles) and produces not more than 20-30 db reduction per shield. Good magnetic contact between parts and seamless construction in the direction where the strongest field is encountered help to make a magnetic shield most effective.

Electromagnetic shields

The essential feature of the magnetic shield is high permeability and high resistivity (or low conductivity); the electromagnetic shield should be non-magnetic and of maximum conductivity. For the same reason, good electrical contact between parts and seamless construction are necessary. Good materials are aluminum or copper.

The electromagnetic shield works by allowing the interfering field to induce currents in the shield, which in turn produce another field that neutralizes the original field inside and augments it outside. The important part is the inside neutralizing action. This is dependent on the conductivity of the shields consisting of Mumetal and copper (Fig. 3).

Since it is the *changing* of the interfering field that induces the currents, this type of shield becomes more effective as frequency increases. For this reason, electromagnetic and magnetic shields can complement one another. Alternating magnetic and electromagnetic shields yield a maximum effective shielding over the full frequency range. This may take the form of alternate shields consisting of Mumetal and copper (Fig. 3).

Electric shields

All that is necessary for a good electric shield is to enclose the shielded area in a metallic or conducting "cage" and to ground the cage. For this, a good ground is needed, but often a connection of several ohms can be considered good. The resistance of a ground connection is always relative. The ground connection for a couple of class-B output tubes must be really low, otherwise operation will be seriously impaired. But electric shielding is used for high-impedance circuits and when you measure circuit impedances in megohms, several hundred ohms is low.

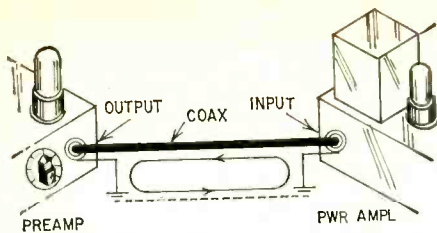

Fig. 4—Example of a ground loop.

The importance of the size of holes in an electric shield is also relative. In a miniature cable with thin insulation, the space between the braid crossings or mesh can be large enough to degrade its effectiveness for electric shielding. A wraparound shield would be more effective because of its more complete coverage, even though it might be slightly inductive, which does not matter for this purpose.

On the other hand, an electric shield with considerable space from the inside of the shield to the circuit to be shielded, can have holes 1/16 or even 1/8 inch in diameter, without deteriorating its electric shielding properties. In fact, perforated metal can be used to allow adequate ventilation.

Ground loops

And what is the story on ground loops? This is closely related to the matter of induction and its cure is similar. Its effect may be an unwanted hum or instability (in the form of oscillation). There are two basic forms of "bad-grounding" trouble, apart from the simple one of no ground at all. Several amplifiers exhibiting a "ticky"

hum were found to be operating with the heater line completely ungrounded. A good ground connection eliminated the tick.

One form of bad grounding does not involve a loop. It happens because the ground is connected in the wrong place, or because one particular connection to the ground bus (or chassis if no bus is used) goes to the wrong place. This results in a common-impedance coupling in the ground connection which may exaggerate an inductive high-frequency (ticky) hum or cause instability.

See that all grounds from each stage are grouped together. When you come to a doubtful one, try connecting it to different points to see which minimizes the effect.

The other is the often mentioned (and almost equally often not understood) ground loop—not one ground path, but two. Two grounds from the same point can cause trouble in one of two ways:

The complete ground connection forms a loop (Fig. 4) and the 60-cycle field present in any building (with that supply frequency) induces currents in the loop that cause hum in the associated circuits. Opening the loop will stop this. But the loop needs to be opened in such a way as to avoid something from being grounded to the wrong place.

It may be necessary to open the ground at the best or the most convenient place and then move some ground connection from one point to another. Work it out on the basis of having the grounds from each stage grouped together and tied in sequence

of stages through the system. This should eliminate the trouble.

The other way a ground loop can cause trouble is by allowing ground current to follow an "unauthorized" path. For stable hum-free operation, all power-supply filter capacitors should be at one end of an amplifier ground bus. The last stage should connect directly to this. Then each stage preceding it should have its ground connected progressively farther away (along the bus) until the first stage. The input ground should go to the first-stage ground and the chassis be grounded to the same point.

Perhaps this procedure has been followed in each of several pieces of equipment. Each has its input grounded to chassis. The units are then connected together and their chassis also make contact. This means their inputs are connected together by chassis contact and each input is connected to an earlier amplifier's output. So now we have ground loops. Follow the above-mentioned principle through the system (by the most convenient method by changing grounds) and any trouble will disappear.

Notice, however, that ground loops do not always cause trouble. Some amplifiers are designed well enough so that connecting their input and output grounds together has not the slightest effect, either on hum or stability. In such equipment, you can clip a lead from any ground point to any other without producing a ground loop effect. So, as we said before, handling these cases is a matter of knowing the "ground" rules. END

TRANSISTORS IN PARALLEL-T

By A. H. TAYLOR

In the diagram, R1, R2, C1, C2, R3, C3 form a null network which balances for one frequency if its elements are in the right proportions. Although more general balance conditions are possible, in practice usually $R1 = R2 = 2R3$, $C1 = C2 = 0.5C3$, and the balance frequency is $f = \frac{1}{2}\pi R1C1$. The negative feedback from collector to base of transistor V is high and gain low except at this balance frequency.

If R3 is reduced or C3 increased slightly from the balance setting, the feedback becomes slightly positive at a slightly different frequency. Gain and selectivity are greatly increased and the amplifier can be made to oscillate if transistor gain is high enough. Positive feedback can also be applied without detuning by taking it in the right polarity from the secondary of the output transformer as shown by the dotted lines, making R8 higher or lower according to whether we want a broad amplifier, a sharp amplifier or an oscillator.

Parallel-T tube amplifiers usually have several stages, but a single transistor stage can have equivalent Q of 100 or more without unwanted oscillation. Only expensive special toroid coils tune this sharply in L-C circuits at audio frequencies. Supply-voltage variation or moderate output loading has

little effect on the frequency of a parallel-T oscillator. Its amplitude is quite sensitive to supply-voltage variations when the feedback is kept low for good waveform; therefore, the oscillator can be amplitude-modulated easily.

A parallel-T network having $R1 = R2 = 27,000$ ohms and $R3 = 13,500$ ohms operates satisfactorily with a variety of transistors, including the 2N35, 2N107, 2N213, 2N270, 2N382. Typical values of the other components:

C1, C2, C3 depend on frequency, see formula given.

C4 large enough so that $X_{C4} < R4$ at operating frequency.

C5 large enough so that $X_{C5} \ll (R1 + R2)$ at any frequency passed by C4.

C7 bypass for R7 at working frequency.

R4 is more than or equal to 10,000 ohms unless signal source impedance is more than or equal to 10,000 ohms.

R5 = 10,000 ohms
R6 = 2,200 ohms for 1.8-ma I_c in a
R7 = 1,000 ohms | 2N213 on 12-volt supply.

NOTE: If the transformer has appreciable primary resistance and R1 and R2 are not varied for tuning, R5, C5, R7 and C7 may be omitted. With 2,500 ohms dc resistance in the transformer primary and R6 = 2,200 ohms, a 2N213 draws 2 ma from a 12-volt supply.

For good selectivity, the transformer must load the amplifier lightly, i.e., reflect a high impedance to it. About 100,000 ohms to 1,000 ohms (Lafayette TR-97 or equivalent) is suitable for driving a low-powered common-emitter stage, and this or 100,000 ohms to 100 ohms (Burstein-Applebee 18B658 or equivalent) will do for an oscillator with R8 between 2,000 and 20,000 ohms, depending on the transistor and transformer used. If R8 is low, increase R6 or use a blocking capacitor. END

References

- H. H. Scott, "A New Type of Selective Circuit and Some Applications," *Proc. IRE*, Feb. 1938, page 224.
- L. C. Cowles, "The Parallel-T Resistance-Capacitance Network," *Proc. IRE*, Dec. 1952, page 1712. Cowles gives a big bibliography including a Bureau of Standards circular with design curves.

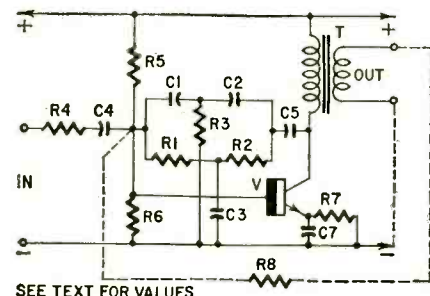

SEE TEXT FOR VALUES

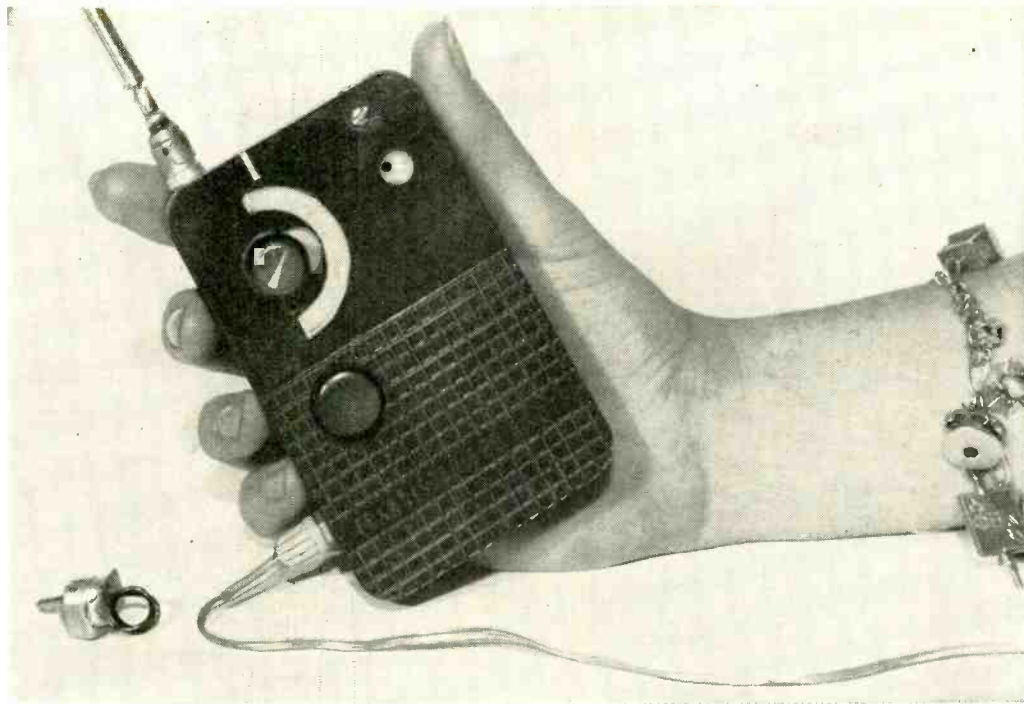

By I. QUEEN
EDITORIAL ASSOCIATE

Receiver exterior. Upper knob is for tuning and lower knob controls regeneration.

Pocket VHF Receiver

PICK UP FIRE AND POLICE CALLS, AN AERONAUTICAL BAND AND THE 27-MC CITIZENS BAND WITH THIS SUPERREGENERATIVE SET

THE superregenerative receiver is a logical choice when high sensitivity at high frequencies is needed in a simple set. This one can go up to 200 mc and is small enough to fit in your pocket. With little effort (and perhaps higher voltage) you should be able to push the upper limit still higher.

A novel plug-in coil system is used. Each coil is soldered to a phono plug (see photo). With two coils, I cover the range from 110 to 165 mc. All parts except the transistor are inexpensive. It is a type 2N1143 by Texas Instruments which sells for around \$12 (latest catalog price). In this set it

loafs while doing an efficient job with only 4 volts at 0.5 ma. To work it at 30 mc, you need less than 1.5 volts. The 2N1143 has a cutoff above 400 mc.

The circuit (Fig. 1) needs little comment. When no external coil is plugged into J2, the collector tank is L2 and is wound for 26 to 30 mc (which covers the interesting Citizens and ham bands). When a coil is plugged in and shunts it, the frequency is raised accordingly. With a two-turn coil (L3), I pick up 140 to 165 mc. With three turns (L4), the range is 110 to 140 (approximately). Both coils are made of No. 16 enameled wire on 1/4-inch diam-

eter forms, turns being spread as required. Plugging in an earpiece at J3 completes the battery circuit. J3 is a modified miniature closed-circuit jack. Fig. 2-a shows the circuit of the original jack. The center contact should be bent down until it is in the position shown in Fig. 2-b. When the plug is inserted, the two upper contacts short together and power is supplied to V1 and the base of V2. The earpiece forms a current path for V2's collector. Remove the earpiece when changing coils.

For best reception, R1 is set to the highest value at which superregeneration occurs. At 30 mc, nearly maximum resistance is best. A collapsible whip antenna plugs into J1.

The band above 110 mc includes many interesting radio services. The one aeronautical band extends from about 108 to 132 mc. Planes and ground stations exchange weather reports, operational data and other messages. Generally the information is brief and routine, but recently I intercepted some real excitement. An aircraft developed landing-gear trouble during flight. For nearly an hour, the tower briefed the pilot on repair while the plane circled the air-

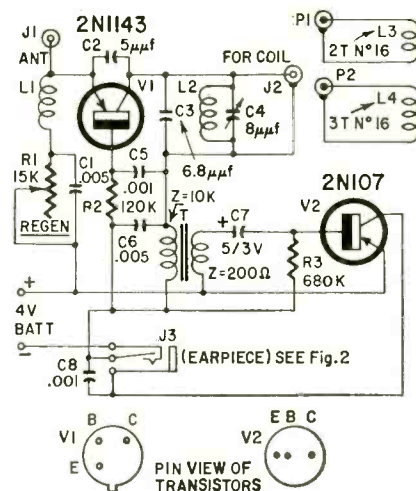

Fig. 1—Schematic of receiver.

- R1—pot. 15,000 ohms
- R2—120,000 ohms, 1/2 watt
- R3—680,000 ohms, 1/2 watt
- C1, 4—.005 μ f, disc ceramic
- C2—5 μ f, disc ceramic
- C3—6.8 μ f, disc ceramic
- C4—variable, 8 μ f max., approx.
- C5, 8—.001 μ f, disc ceramic
- C7—5 μ f, 3 volts, electrolytic
- V1—2N1143
- V2—2N107
- L1—40 turns No. 34 enameled, on 1/2-watt resistor (47,000 ohms or larger)
- L2—25 turns No. 22 enameled, on 1/4-inch polystyrene tube or rod
- L3—2 turns No. 16 enameled, air-wound (1/4-inch diameter) on phono plug
- L4—3 turns No. 16 enameled, air-wound (1/4-inch diameter) on phono plug
- T—primary, 10,000 ohms; secondary 200 ohms (United Transformer Co. SO-3 or equivalent)
- J1, J2—phono jacks
- J3—see text
- P1, P2—phono plugs
- BATT—3 1.25-volt rechargeable nickel-cadmium cells (Eveready No. N32T or equivalent)
- Case, plastic, 4 1/8 x 2 3/8 x 1 1/8 inches (Lafayette MS-302 or equivalent)
- Earpiece, 1,500 ohms (dc) with plug (Lafayette MS-260 or equivalent)
- Perforated phenolic board for chassis
- Miscellaneous hardware, knobs and sockets

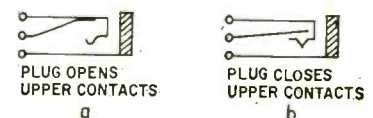
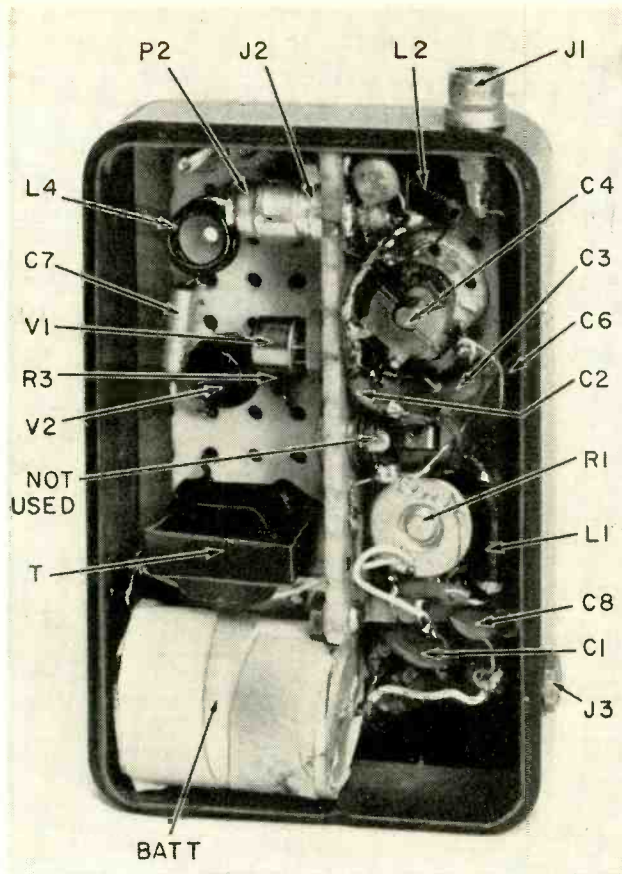

Fig. 2—J3, a—before modification; and b—after modification.

BASS-REFLEX

speaker enclosures



Interior of receiver.

A BASS-REFLEX speaker enclosure is often recommended because the tuning effect of its port subdues the resonance peak and spreads the speaker resonance over a wider band of frequencies than does an enclosure without a port.

The enclosures described here were designed by Quam-Nichols for Quam speakers, but will work well with many other units.

The enclosure should be made of 3/4-inch plywood or some similar heavy, well seasoned wood. Assemble with screws, not nails, and glue all edges to insure a completely rigid baffle. Use glue blocks or some other type of bracing at the inside corners. Make the back removable by fastening it only with screws placed about 4 to 5 inches apart along all four edges.

port. After an apparently satisfactory repair, the tower wished him "Good luck" and the plane landed.

Near 155 mc I pick up local fire headquarters announcing alarms and contacting the chief at the scene of fires. Progress reports are made from the scene back to headquarters. A short time ago an odd incident occurred. Hearing fire apparatus coming down my street, I rushed for the pocket receiver. The engines stopped a few houses away. It turned out to be a small fire according to the progress reports I heard. Replies from headquarters were audible not only from my set, but also from the speaker mounted on the fire engine (as a sort of echo).

One ham band extends from 144 to 148 mc. I have heard stations up to several miles away. The range increases greatly as you gain height.

All parts are mounted on a 2 x 3-inch perforated board, except for J1 and 3. A small "shelf" about 1/2 inch wide holds J2 and transistor V1. The photo shows another earpiece jack on this shelf, but it is not needed. I use it for experimenting and measurement. J1 is at the top of the box, (Lafayette part, No. MS-302) J3 at the side.

As mentioned, you need only 1.5 volts

or so for 30 mc and about 4 volts up to 175 mc. There seems to be little on the market in the way of a tiny 4-volt battery, so I use three rechargeable cells soldered together. You can also use small penlight cells.

For the coils use phono plugs that have metal grips. One end of the wire goes inside the pin, the other to the metal grip.

Centering the 30-mc band requires some care. Use about 32 turns of No. 26 enameled wire on a 1/4-inch polystyrene rod or tube. Remove one or two turns at a time until you have centered the band (26 to 30 mc) within the range of the capacitor. This band is good for coast-to-coast reception at certain times and is always good for locals on both the Citizens and ham bands. For very short-distance reception, you may keep the set in your pocket (without antenna) yet hear clearly on the earpiece.

C3 shunts the variable tuning capacitor to reduce the tuning range (makes it easier to tune). If your C4 is too long (to permit closing the box cover), remove one or two plates. On my unit the plate diameter is only 7/16 inch.

For frequencies near 200 mc, increase battery voltage to 6 or 9. END

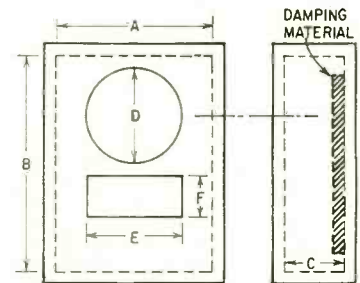

Use some kind of sound-damping material (about 1 inch thick fiber glass or Ozite) to line the baffle. This reduces resonance effects. The grille cloth should be an open-weave material that permits free passage of all frequencies.

Dimensions shown in the table have been developed by the Quam Engineering Dept.

Speaker Size (inches)	Cabinet Dimensions (inches)				Vent Size (inches)	
	A	B	C	D	E	F
15	29	39 1/2	15 3/4	13 1/2	21	7 1/4
12	24 1/2	32 1/2	13 1/4	11	16 1/2	5 1/4
10	20 1/2	27	10	9	12 1/2	4
8	16 3/4	22	9 1/4	7	9 1/4	3

Midget receiver uses two transistors and plug-in coils to cover 26-30, 110-140 and 140-165 mc. Rechargeable batteries make it economical to use.

Unit was tested by a member of the staff of RADIO-ELECTRONICS at a location some 10 miles from International Airport in New York City. Transmissions from the tower and from planes in the air could be easily followed. When set for the 27-mc Citizens band, several local stations were picked up. How far they were from the receiver could not be determined. In all, receiver performance was excellent.

BENCH



TESTED

WHAT'S NEW

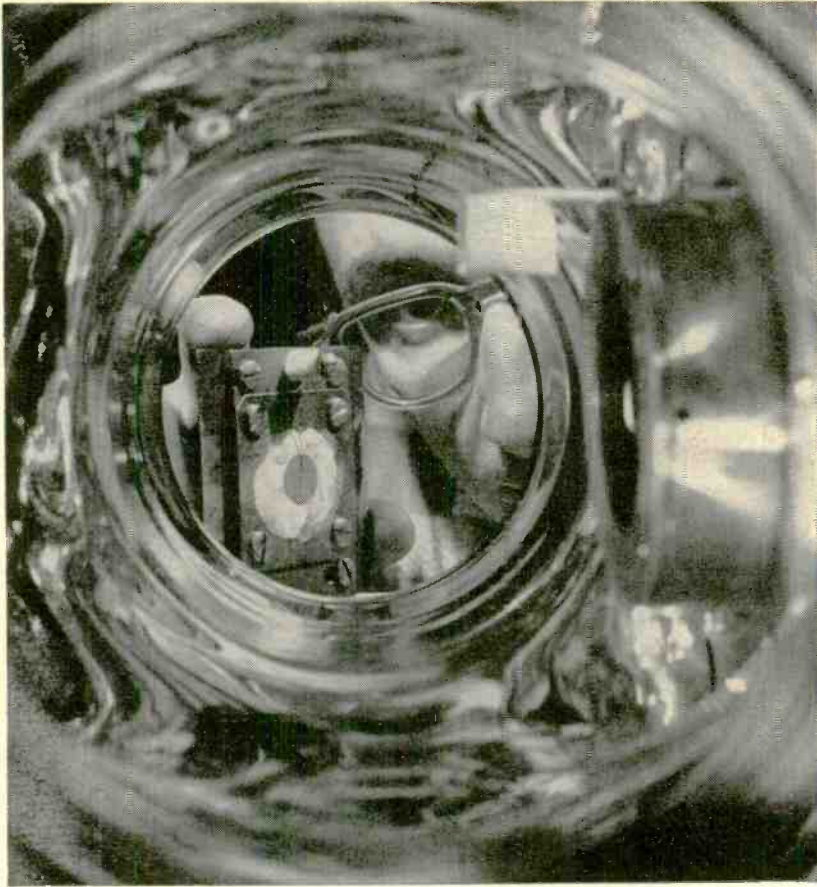

RADIATION-RESISTANT solar cell is being placed into chamber of Van de Graaf particle accelerator to test its atomic endurance. Developed by Army Signal Research and Development Laboratory, Ft. Monmouth, N. J., cell consists of a small disc of specially treated silicon and is mounted on a copper block for the test. This type of cell would be used on space vehicles, where extremes of radiation might be encountered.

METER COIL (quarter-sized, flat printed circuit in center of photo) forms heart of series of very thin panel meters. Combination of nylon bristle pointer and printed-circuit coil prevents even 10,000% overloads from damaging movement. For complete front, side views, July, page 45. Parker Electrical Instrument Co.

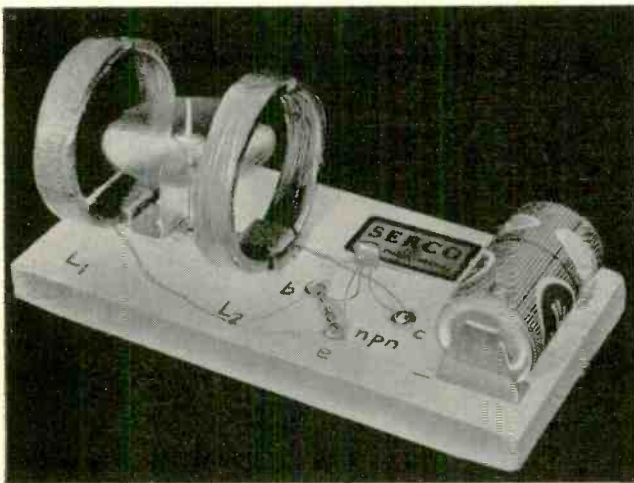
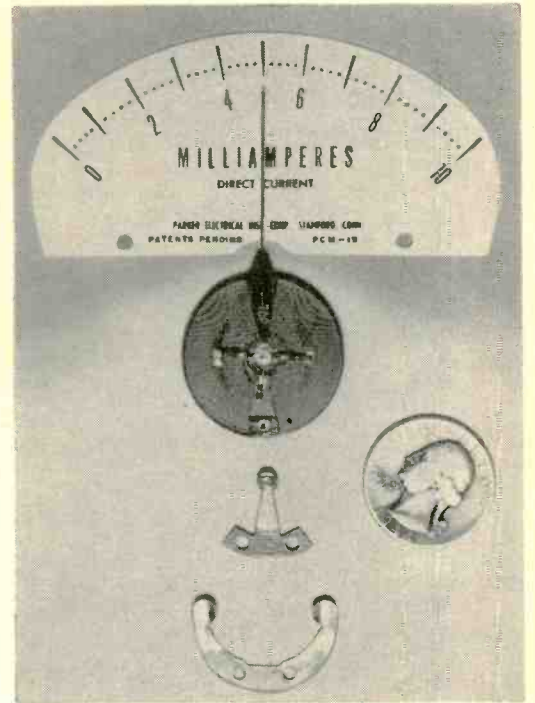

AUTOMOTIVE RECORD PLAYER handles 45-rpm records. One-hand operation—a record is pushed into the slot—designed for safety. All other operations are automatic. After record is played, it automatically slides out of the slot. Produced by Norelco, it operates off 6 or 12 volts. Car radio acts as the amplifier. An RCA automotive changer was described in December 1959, page 54.

ELECTRONIC MOTOR runs on dc, yet needs no brushes or commutator. A switching transistor replaces them in this educational kit made by SER Inc., Waltham, Mass.

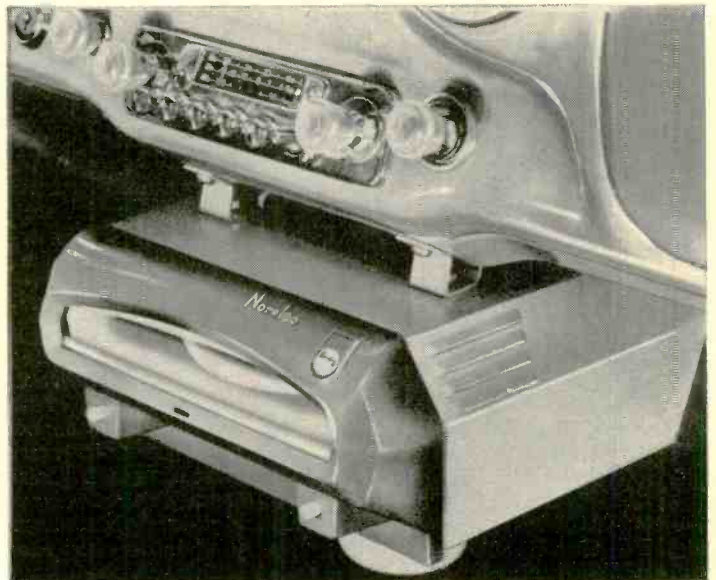

TV

DESIGNS FOR

'61

A look at circuitry and design features of TV sets for 1961 reveals new and interesting circuits and construction methods that simplify servicing

By WAYNE LEMONS

THE gamut of 1961 television design runs from virtually no change to major reworking of 1960 circuits and layouts. The 19- and 23-inch picture tubes are in to stay, replacing the 17- and 21-inch types as the standard of the industry. Almost every manufacturer features wireless remote-control units. The receiving units of the remotes are mostly similar, operating in the vicinity of 40 kc so as to be least affected by the set's horizontal sweep system. The portable hand-held transmitting units are about equally divided between the transistor and "hammer-and-rod" types.

Printed and hand-wired circuitry is exactly in the same ratio as last year.

There seems to be quite an upsurge in the use of the neutralized triode as an rf amplifier in tuners. Proponents of triode design claim as much or more gain than the cascode circuit and less noise. One RCA tuner uses a 6CW4 nuvistor triode that is said to give 30% less noise than other triodes on the high

channels. Pentode mixers are universally used. Oscillator drift has been cut to a minimum so that fine tuning may be set once and practically forgotten. Several tuners have a trimmer for adjusting tuner-oscillator tuning to compensate for capacitance changes due to tube changes etc.

"Cascode" or stacked if amplifiers are more common in 1961, and some new tubes with higher gain have been introduced for if service. The stacked if has the advantages of less current drain from the B-plus supply and better signal-noise ratio because of the regulation of the first if plate supply by the second if. A simplified schematic of the stacked system is shown in Fig. 1. The voltage division across the tubes is maintained, regardless of the respective tube condition, by resistors R1 and R2, which hold the grid voltage of V2 constant. Since the tube currents are in series, it is necessary to apply age only to V1.

There seems to be an increase in sets using high-level contrast-control circuits—meaning the contrast is between the video amplifier plate and the cathode (or grid) of the picture tube. High-level contrast control has the advantage that the gain of the video amplifier stage is not changed and thus the signal level to the sync separators is not affected by the position of the contrast control. Fig. 2 shows one of the simplest high-level contrast-control circuits as used in Dumont chassis 120601-A.

Power supplies are nearly all of the

power-transformer type. Several companies make portables with the transformerless chassis, however, and Sylvania for one uses it in all its lines. Most companies have some sort of circuit protective device in either the transformer primary or secondary circuits, a marked improvement over last year.

We found no Synchroguide horizontal oscillator circuits in anybody's black-and-white design for 1961. The closest is the circuit used last year and this year by RCA (more on that later). The multivibrator with semiconductor diode phase detectors is by far the most popular circuit, and the 6CG7 tube is the modern "standard" multivibrator replacing the 6SN7 of years past. A few companies are using a triode-pentode (6U8, 6EA8, etc.) in a combination reactance tube and Hartley electron-coupled oscillator circuit. Fig. 3 is a circuit of this type used by Zenith.

Vertical sweep circuits are almost all the oscillator-output multivibrator type with a pulse from the output tube coupled back into the input tube to sustain oscillation. One of the simplest (Fig. 4) of these is used in Emerson chassis 120507, -508, -515, -516, -541, -542. Note the similarity to a conventional amplifier circuit except for the feedback circuit enclosed in the dotted lines. In this circuit, as in most of this type, the normal bias developed by the oscillator is tapped off by the vertical linearity control and applied to the grid of the output tube to adjust circuit linearity. As in all these circuits, the controls interact so that setting one may necessitate readjustment of the other two.

High-voltage circuits are about the same as last year with some manufacturers claiming even higher output voltages. About the extreme amount claimed for black-and-white sets is by Zenith—22 kv. The shorter 1G3, 1J3,

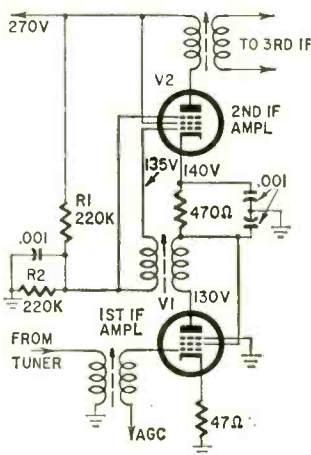

Fig. 1—Simplified stacked if stages. R1 and R2 set bias level for V2.

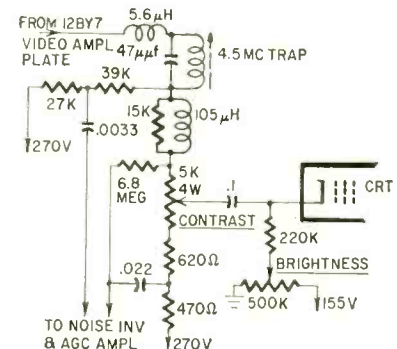

Fig. 2—High-level contrast control used in Du Mont television receivers.

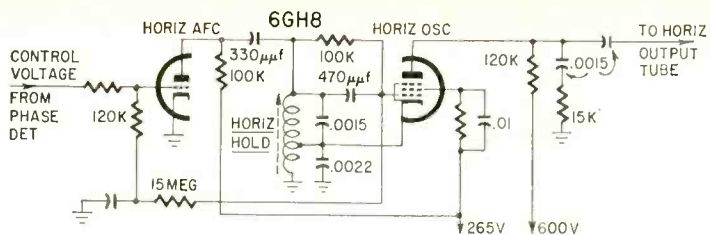

Fig. 3—Simplified diagram of Zenith's horizontal oscillator and control circuit.

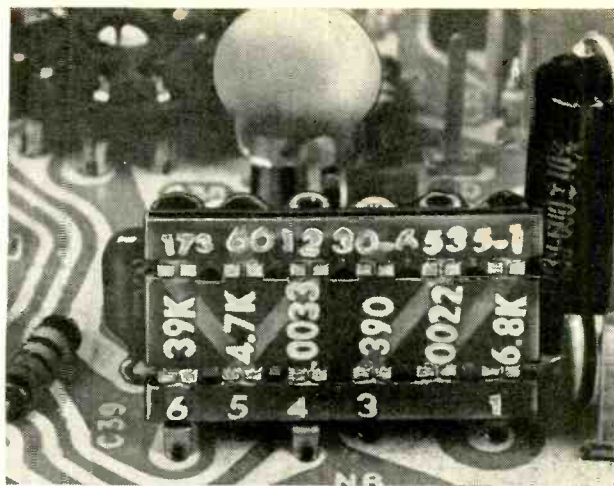

Fig. 5-a—Values of all parts and connections are clearly marked on rear of pack used in several Emerson chassis.

etc. is used instead of the older 1B3 in many chassis. Motorola is using the 3A3 in many of its models again this year. To prevent high-voltage rectifier breakdown, many manufacturers are including a series limiting resistor (5,000 to 10,000 ohms) from the rectifier to the newer high-capacitance picture tubes.

Gated-beam sound detectors are used by most manufacturers, although G-E, DuMont and Hoffman have one or more models using a ratio detector.

Motorola is producing a large-screen (19-inch) transistor TV. (See *RADIO-ELECTRONICS*, September 1960.) It operates 5 to 6 hours on a self-contained, rechargeable silver-cadmium battery. The picture tube has a 12-volt heater. Only one other tube is used, a 1S2 high-voltage rectifier.

Audio amplifiers are pretty well standard with a trend toward the use of the high-sensitivity, higher-power 6BQ5/EL84 as an output tube. Since the stacked if circuit lessens the need for using the audio output tube as a voltage divider, it has just about been discontinued. However, Emerson and G-E use the circuit in some models. The output tube, in this case, is a 6CU5.

RCA is still the only manufacturer of color sets. No major changes in the circuit are evident although the convergence procedure is said to be simplified and the chassis layout changed to provide cooler operation. A new focus circuit eliminates the focus pot as a possible source of trouble.

There are some new if amplifier tubes and vertical oscillator-output tubes, and a new rectifier by Zenith, a 3DG4. More or less, the tube types you'll be seeing in the 1961 models will be familiar.

Serviceability and accessibility

Most manufacturers have improved accessibility and have provided special features to aid the service technician.

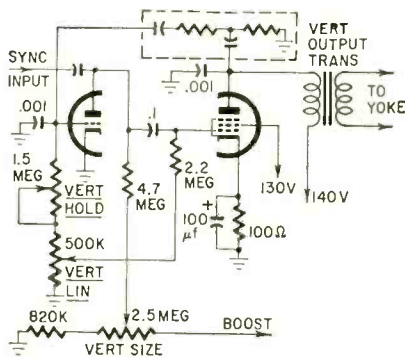

Fig. 4—Emerson's vertical oscillator and output circuit looks like an audio oscillator with positive feedback added.

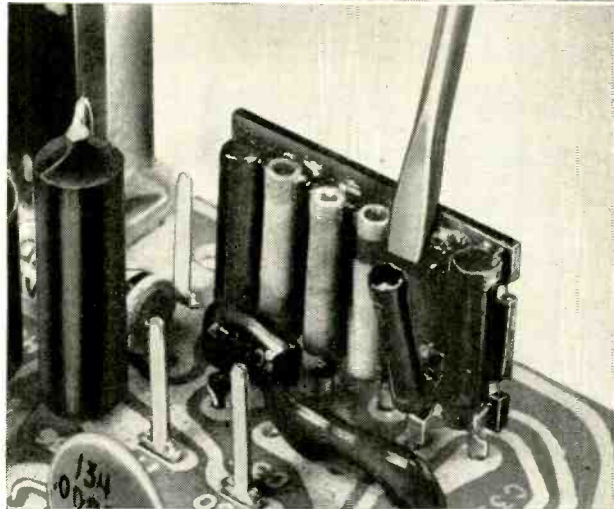

Fig. 5-b—A defective component, once located, can be pried loose with a screwdriver.

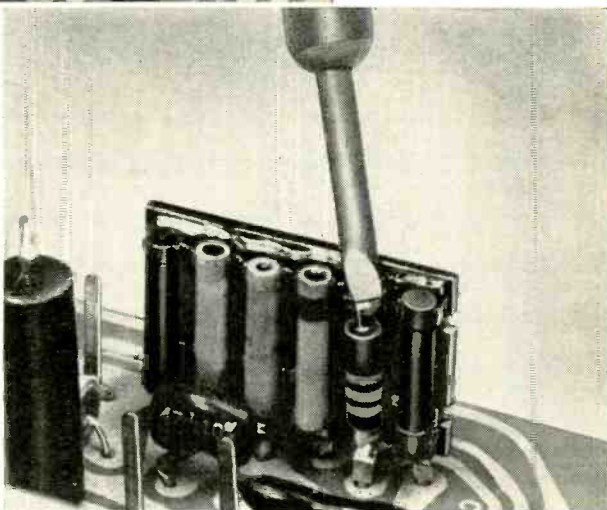

Fig. 5-c—Repair is completed by soldering standard component in pack to replace defective section.

Something new in packaged components is the Philco component pack (Fig. 5). In (a), the reverse side of the pack shows the value of the component and the internal connections. Fig. 5-b shows a screwdriver prying loose the defective component. Installing a replacement with a soldering iron is depicted in (c).

Other features to soothe the sting of servicing are the provisions made by some manufacturers (G-E, Motorola, Sylvania and others) whose tuners are mounted separately from the chassis. They provide for mounting the tuner on the chassis while transporting for service and while servicing.

Unfortunately, with 23-inch tubes, you just don't find them mounted on chassis it seems. Yoke extensions and test picture tubes will be needed as much or more than ever when these sets require chassis work.

Now let's take a look at the major manufacturers in alphabetical order and hit the high points of the 1961 designs.

Admiral

There are virtually no changes from last year in the 1961 chassis—same tubes, same circuits, same etched boards guaranteed for 5 years. A yoke plug on 23-inch models makes them easier to

6CL8 converter-oscillator tube. The 12-position Oak tuner uses a 6EA8. Replacing the antenna transformers in all the new tuners is comparatively easy. The Oak tuner has a hole in the rear so that the antenna input transformer lead can be disconnected easily. Fig. 11 shows the overall oscillator adjustment that can be used to recenter the channels when an oscillator tube is replaced. The U5 chassis has a cascade miniaturized Oak tuner—except for smaller size, the same as last year's U4 tuners.

Only one size of picture tube is used with the U5 chassis—the 23KP4.

As last year, G-E's watchword in the "designer" chassis is accessibility. Almost all repair work can be done without taking the chassis to the shop. This includes even the flyback transformer if you follow the recommended procedure of separating the two halves of the transformer core to permit sliding off the high-voltage rectifier filament winding (Fig. 12). CAUTION: Do not remove the two pieces of tape that are applied to the ends of the core halves!

G-E's two-button remote changes channels and increases volume or mutes the receiver. It will also turn the set off when the tuner is moved to the uhf position (on non-uhf sets). Uhf sets may be set to turn off on any inactive channel but are shipped from the factory with the off position on channel 9. This year's remote volume is in the signal circuit instead of the screen circuit of the audio if as last year.

Mechanically, the 17- and 19-inch models are similar to the 1960 M5, having the tuner and bracket assembly attached to the chassis. The 21- and 23-inch models of this year, however, have the tuner and bracket assembly attached directly to the cabinet front. A ground strap is riveted to the tuner and this should always be attached to the main chassis; otherwise, regeneration and tweets may develop. The tuner bracket assembly may be stowed on the chassis by special hooks provided for this purpose, if it is necessary to remove the chassis for service (Fig. 13).

Bonded safety faceplates are *not* used on the 19- and 23-inch G-E models. A removable safety glass is used instead.

Hoffman chassis 351 to 359

All these models are transformer-powered. All except the 355, which has silicon rectifiers, use 5U4-GB's. All either have circuit breakers or fuses in the primary circuit of the power transformer and either continuous or step type variable focus control. Chassis 354, 357 and 359 have a "Lite Scope," a device for automatically controlling brightness, depending on ambient light conditions. (See "New Automatic TV Brightness Control," RADIO-ELECTRONICS, September 1960, for other details on the Lite Scope circuit.)

All have essentially the same, pretty straightforward, circuitry. They have keyed agc, tube type video and horizontal phase detectors. All except the 354, which has a 6BN8 ratio detector, use 6DT6 gated-beam sound detectors.



Fig. 11 — Tuner in G-E's M6 chassis. The oscillator trimmer is near the output jack.

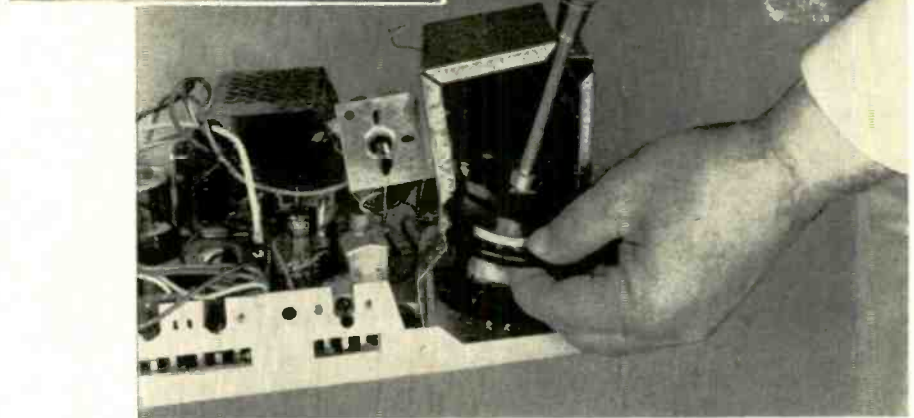

Fig. 12 — Flyback transformer in new G-E sets can be replaced without removing chassis from cabinet or pulling set to shop.

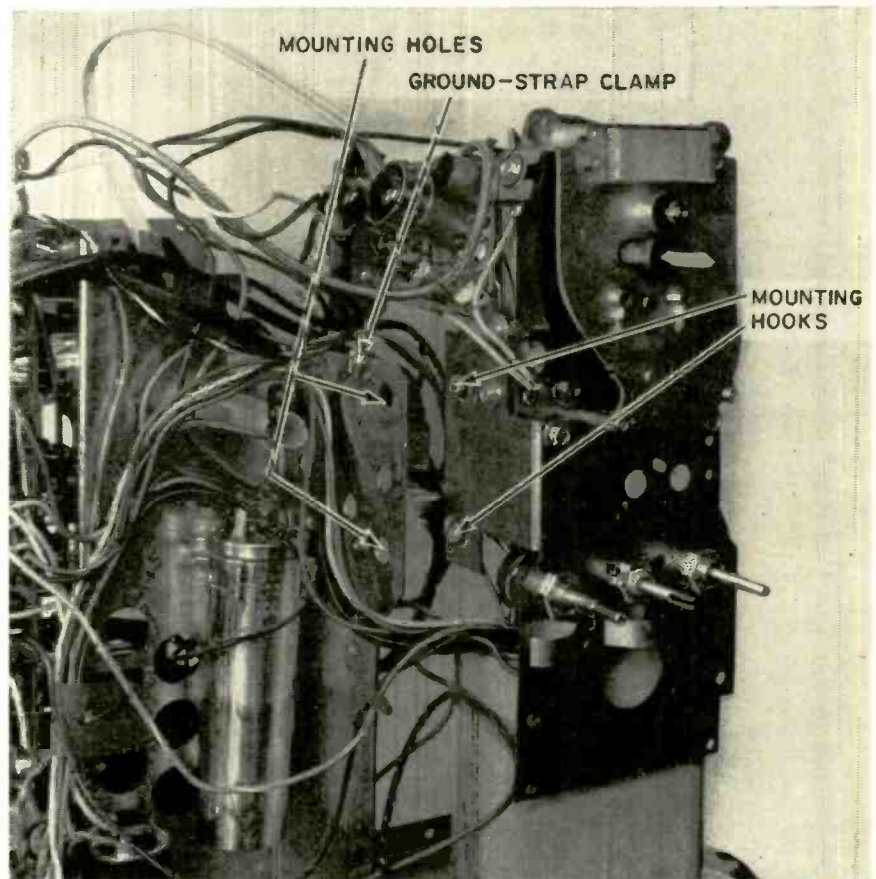

Fig. 13—G-E tuner hooks onto chassis for easy transporting.

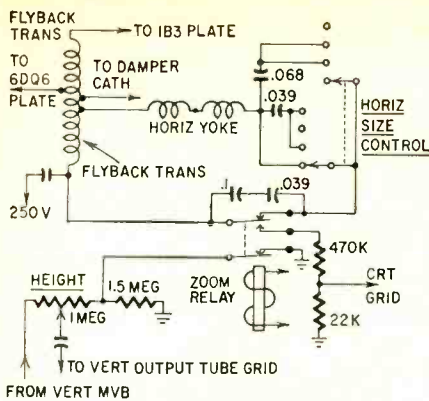

Fig. 14—Hoffman picture-magnifier circuit is controlled by wireless remote.

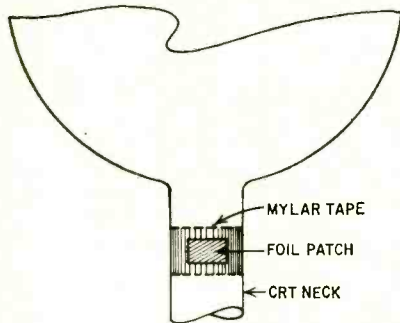

Fig. 15—Foil patch on CRT neck insures optimum horizontal linearity in Hoffman sets. Remove and re-install on replacement CRT's.

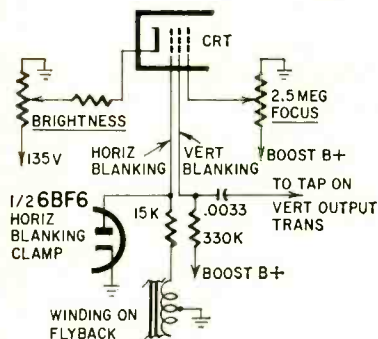

Fig. 16—Magnavox horizontal and vertical blanking circuits.

All use a double-triode direct-coupled sync separator circuit.

Hoffman remotes are similar to other wireless models except for the ZOOM position on some models. This circuit, reminiscent of "enlarging" circuits used when small round tubes were popular, increases the picture size both vertically and horizontally when the ZOOM button is depressed. Pressing the button again returns the picture to normal size. The ZOOM relay circuit is shown in Fig. 14. Note that a contact on the relay applies boost voltage through a bleeder to the grid of the picture tube; this compensates for a loss of brightness when the picture is "zoomed." Note also that the height control varies the signal output from the vertical multivibrator to the vertical output tube instead of varying the voltage on the multivibrator plate. This prevents the oscillator from changing frequency when the picture is magnified.

Hoffman sets using 19- and 23-inch

picture tubes have a foil patch held in place on the neck of the tube by Mylar tape. This foil patch should be installed on a replacement picture tube to provide optimum horizontal linearity (Fig. 15).

Magnavox series 32, 33, 34

These chassis are all similar except that the 32 series has average rather than keyed age. The 33 series is one of the few designs this year that use a vertical blocking oscillator circuit. Series 32 and 34 utilize both vertical and horizontal blanking (Fig. 16). An interesting feature of the horizontal blanking circuit is the clamping-tube diode used to prevent spurious responses in a positive direction from affecting picture-tube brightness. Vertical blanking is applied to the first anode rather than the more conventional method of applying it either to the grid or cathode of the CRT.

These are all power-transformer chassis with 5U4-GB rectifiers. They have 6CG7 horizontal multivibrators with series type semiconductor diode phase detectors. Low voltage (+135) for the if amplifiers is taken from the cathode of the 6DG6/6W6 audio output tube. The 32 series uses a 17DKP4 picture tube, 33 series either a 21DLP4 or 24AUP4, and 34 series either a 19YP4 or 23MP4.

A variable-inductance width coil is used on the 33 and 34 series. There is no width control on the 32 series.

Motorola

In addition to the first big-screen transistor TV, Motorola has added 19- and 23-inch tube sets to its 1961 line. All except 17-inch portables, models

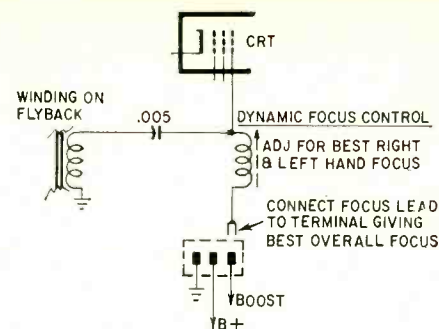

Fig. 17—Motorola uses dynamic focus control.

17P6 and 17T37, are hand-wired chassis, both with and without power transformers. Circuits are similar to 1960 models. Motorola is the only manufacturer using 3A3 high-voltage rectifiers in monochrome sets. (In the 17-inch portable they use a 1S2-A.)

All models use nine-pin "double-ended" damper tubes, either the 6AL3/6AF3 or 12AF3.

All have some method of adjusting the horizontal size; most use a 5,000-ohm pot in the horizontal amplifier screen circuit.

Dynamic focus of the 23GP4 picture tube is provided in the VTS-569 chassis. Dynamic focusing is said to give better focusing on short-neck wide-angle tubes. This is done by controlling the focus voltage in relation to the position of the spot on the screen (Fig. 17). The focus-coil adjustment is made for the best left- and right-hand focus; the tap is set for the best overall focus.

All transformer-powered models use 3BZ6 first and second if tubes in a stacked if circuit. The 3-volt heaters

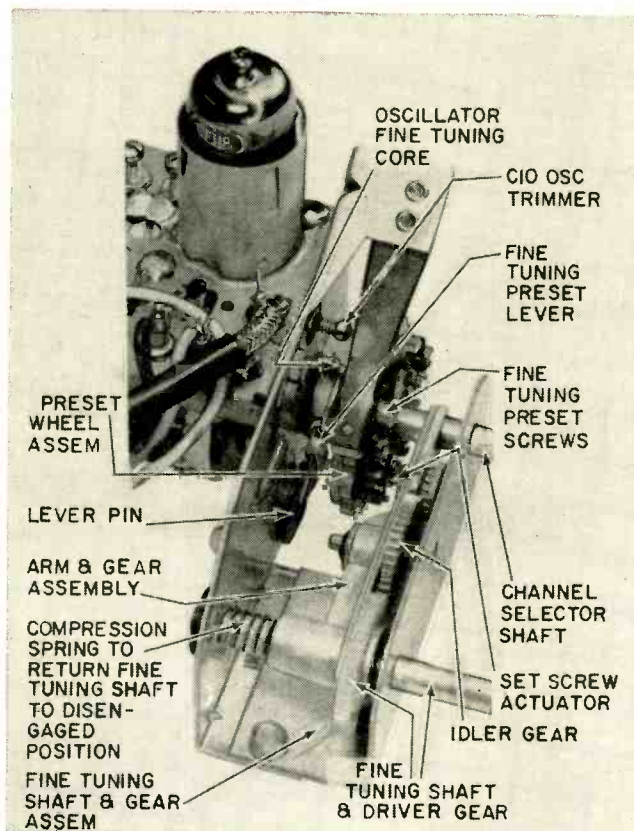

Fig. 18—Motorola fine tuning system. C10, for overall oscillator adjustment, is accessible when channel-selector knob is removed.

are connected in series across the 6-volt heater winding of the power transformer. So, in this case, if you see 3-volt tubes, it doesn't indicate necessarily that the set is a transformerless one.

Tuners on the new Motorolas are smaller and easier to service than earlier counterparts. A complete switch wafer may be replaced with comparative ease. The wafers may be crimped in the retaining bar but they can be released with a pair of long-nose pliers. An overall oscillator adjustment C10 (Fig. 18) is accessible when the channel-selector knob is removed. It may be used to recenter the high channels when a new mixer-oscillator tube is installed. Preset fine-tuning adjustments are provided on most models also.

Philco

Philco has a new tuner this year. It features shorter leads, made possible by recessing the tubes right into the tuner body. It uses a "frame-grid" amplifier tube, the 6ES8, for lower noise and higher gain. (Pin connections for the 6ES8 are the same as for the 6BQ7.) There is an individual oscillator adjustment for each channel in this switch type tuner. To remove the tuner for service, take out the Phillips-head screws from the dial plate and remove it. Then take out the two 1/4-inch hex-head screws that are exposed. Now remove the if link plug and disconnect the power cable plug. Remove the two hex screws supporting the tuner at the rear and slide the tuner out (Fig. 19).

Other features of the 1961 "cool chassis" Philco are the stacked if stages and a new tube, a 6HJ8, third if and video detector. The contrast control is in the cathode of the video output tube, but in reality it doesn't affect the gain of the video amplifier tube to a large extent. It is bypassed by a 100- μ f capacitor. It functions by controlling the bias on the tube which, in turn, controls the bias on the agc keyer. Thus turning up the contrast actually reduces the agc voltage, and the gain of the set is increased (Fig. 20).

A NOISE-ADJ control sets the conducting point of the noise inverter tube (half of a 6EA8). Fig. 21 is the circuit, showing the composite video and inverted noise paths through the circuit. Adjust the noise control as follows:

1. Use a weak signal; remove the antenna if necessary.
2. Shunt the noise control with an 18,000-ohm resistor.
3. Adjust the fine tuning for a slight sound beat in the picture.
4. Adjust the noise control until the picture appears watery—this is caused by the noise inverter passing some inverted sync signal.
5. Back off the noise control slightly until the picture is steady.
6. Remove the shunt resistor.

The reasons may not be apparent at first glance for the 10-megohm resistor from the center arm of the brightness control to the lower end of the grid resistor in the vertical output stage, (Fig. 22) or why the brightness control is in the ground leg of the width

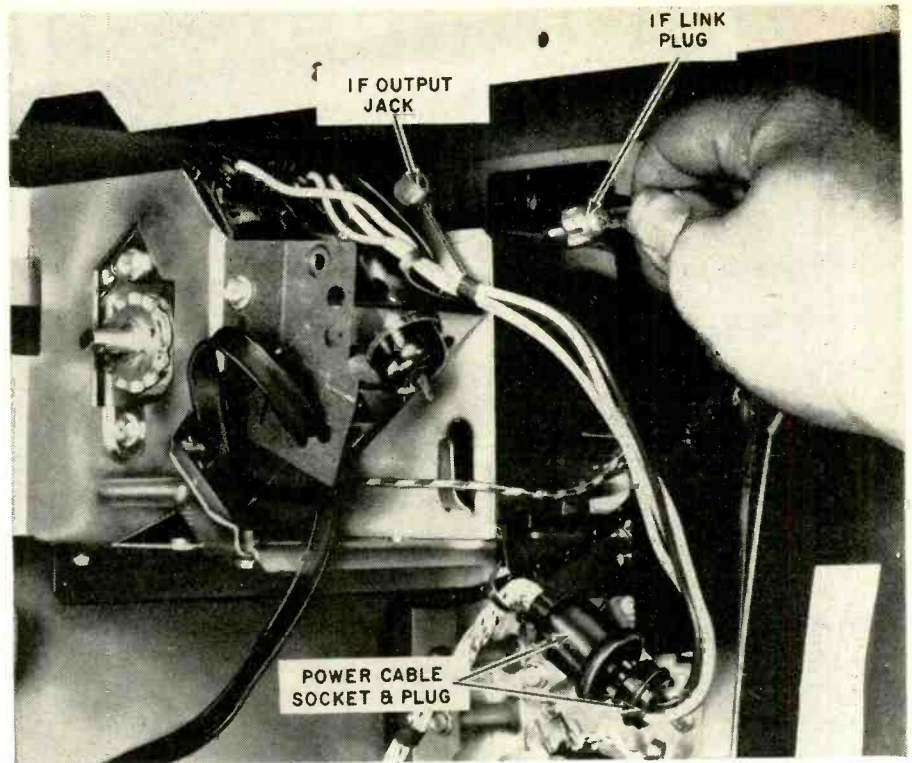

Fig. 19—Removing the Philco tuner.

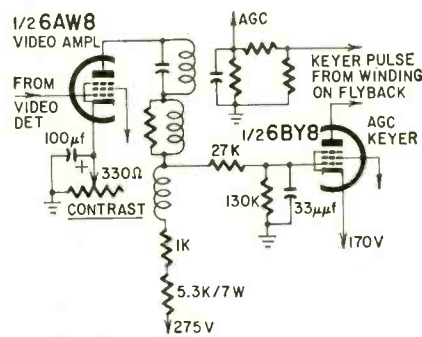

Fig. 20—Philco contrast control varies receiver gain by adjusting bias on the grid of the agc keyer tube.

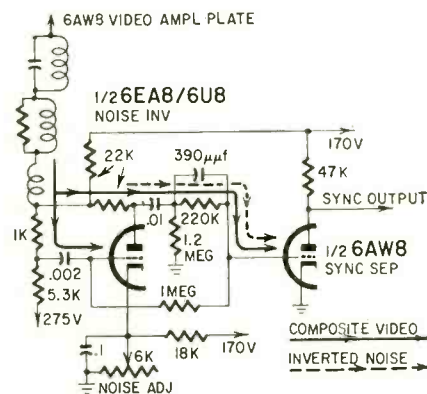

Fig. 21—Philco's noise-inverter circuit.

control. This circuitry makes up a "brightness-size" compensation network. Brightness-size compensation is needed because regulation of a high-voltage system is something less than ideal. When brightness is turned up, the picture tube draws more current. This reduces the high voltage, and the raster size will increase slightly because the electron beam is now easier to sweep.

Vertical compensation is achieved by feeding back a positive voltage to buck the normal negative bias on the vertical output tube. (The negative bias is taken from the grid circuit of the horizontal output tube.) As the brightness is increased (brightness-control arm going toward ground), there is less positive bucking voltage. This lets the grid go more negative and reduces the picture.

The brightness-width compensation would appear to be connected in reverse. As the brightness is increased, there is less shunting action by the 39,000-ohm resistor (R38). This would seem to increase rather than decrease the width because the screen voltage of the horizontal output tube is increased. However, in practice, the high voltage tends to be increased by this action faster than the width is, and compensation results. The brightness-size compensation tracking is said to be good.

This year, as in 1960, all RCA's, including portables, have power transformers. A stacked if system is used and a new tube, 6GM6, is the second if amplifier. This tube has considerably higher gain than its predecessor. Most

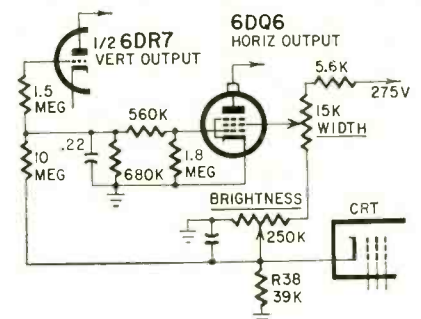

Fig. 22—Brightness and size compensation circuits in Philco sets.

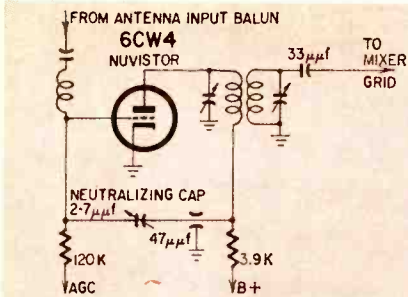

Fig. 23—Simplified circuit shows neutralized nuvistor rf amplifier in RCA tuner.

RCA tuners are of the neutralized triode type, even on color sets. RCA claims that these tuners equal or exceed the gain of cascode types and produce less noise. One model uses the RCA nuvistor triode (6CW4). (See "Nuvistor, New Electronic Tube" in the June, 1959 issue.) Less noise is claimed for this type of construction because the tube can be heated to high temperatures for driving out impurities without damage. Fig. 23 is a simplified circuit of the "New Vista" tuner showing the method of neutralization. The neutralizing capacitor feeds an out-of-phase signal back to the grid to cancel out the grid-plate capacitance of the tube and thus prevent oscillation.

High-level contrast control is used in all models (Fig. 24). A peculiar trouble, which might be diagnosed as a defective picture tube, occurs if the 6,800-ohm resistor (R228) opens. This increases the video amplifier's plate load resistance to above 30,000 ohms, and pictures take on a "milky" look similar to a gassy picture tube.

The horizontal oscillator, sometimes called the "synchromatic," is the same as introduced by RCA last year. (Fig. 25.) A scope is *not* necessary in the setup procedure as it was with its cousin in the Synchrophase. To adjust the sine-wave coil, first short it out with a jumper and then ground the grid of the sync output tube (6EA8). Now adjust the horizontal hold control until the picture is steady or moving slowly sideways. Remove the short from the sine-wave coil and adjust it for a straight-sided picture. Remove the short from the sync circuit. The picture should lock in perfectly. If the adjustment is correct, shorting or unshorting the sine-wave coil (not the oscillator coil) will not cause the picture to go out of sync but merely shift it sideways slightly.

The Synchroguide oscillator in the RCA color sets is shown in Fig. 26. Note the use of phase-detector diodes instead of the pulse-width afc system. The left section of the 6CG7 is the oscillator control. Its plate voltage raises or lowers the oscillator bias to control the oscillator speed.

RCA seems to have the only remote that will completely turn off both the TV set and the remote-receiver amplifier. A pneumatic switch delays the off action for 5 seconds so that the remote operator may pass through the off position (on the tuner) and continue to select channels. However, if the operator delays more than 5 seconds, both

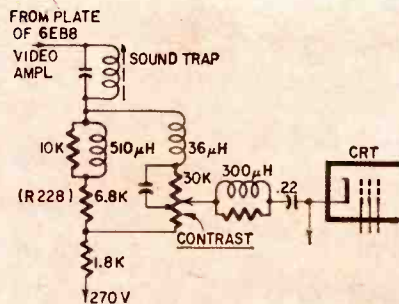

Fig. 24—Contrast control is high-level type in all RCA 1961 chassis.

the set and amplifier will turn off and it is then necessary to turn the set back on manually before the remote can be used again. A standby position is provided also which cuts off both picture and sound but leaves the set and the remote amplifier turned on. RCA remotes have four volume levels instead of three.

All 23-inch sets have tubes with bonded faceplates and stereo input jacks.

Sylvania 550-1, -2, -3, -7, -8, -9

These chassis are transformerless types with three 3BZ6 if's, the first two in this year's popular stacked-if circuitry. A 1N295 shunt video detector is used (Fig. 27). The shunt detector is not used much since most manufacturers seem to prefer a secondary winding on the detector if transformer and place the diode in series with the signal. When no secondary is used, as on these sets, the shunt arrangement is ideal since the diode can act as its own dc return. (A diode will block if not provided with a dc return path around it.)

An 8ET7 duo-diode-pentode is used as a combination video amplifier and horizontal phase detector. A 3CS6 is used as sync separator and noise gate. A 10EG7 is the twin-triode vertical oscillator-output tube.

The transformerless chassis has no protective devices in the heater circuit. However, a circuit breaker is used in series with the silicon-diode voltage-doubler power supply.

Sylvania's wireless remote receiver is unusual in that only one tube is used—a 6AW8. The pentode section is used as the first amplifier, feeding the triode

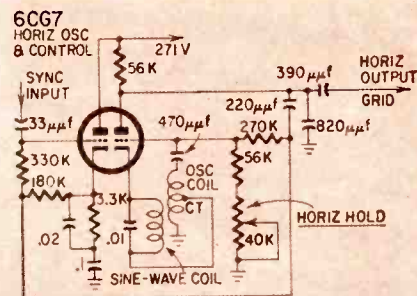

Fig. 25—RCA horizontal oscillator and control circuit.

section. The triode is connected in a reflex circuit which amplifies the remote-transmitted signal and feeds it to a diode voltage-doubler circuit which in turn biases the triode to trip the relay in its plate circuit.

This remote changes channels and turns the set off and on. (Only one button is used—the off-on switch is actuated by the channel selector.) It represents quite a departure in design from most remotes which employ several tubes. Although probably not as selective as some remotes, it has the obvious advantage of being easy on the electric bill when operated continuously, as remotes ordinary are required to do. Full details on this remote control will appear in a full-length story in an early issue.

Fig. 28 shows the 1961 Sylvania mounted in the cabinet. Fig. 29 shows the chassis removed and the tuner and control assembly mounted for transporting to the service shop when necessary.

Westinghouse

Westinghouse has 17- and 19-inch portables for 1961 with transformerless chassis. They have transformer-powered 19- and 23-inch sets. There are no 21-inch sets in the line.

All chassis use the stacked if circuit. Keyed agc is used in the 23-inch sets but all others have average type agc taken from the video detector. All have noise inverters using the triode half of a 6FV8.

Transformer sets have a 3.5-amp slow-blow fuse in the primary circuit of the power transformer. Transformerless sets have no surge protection in

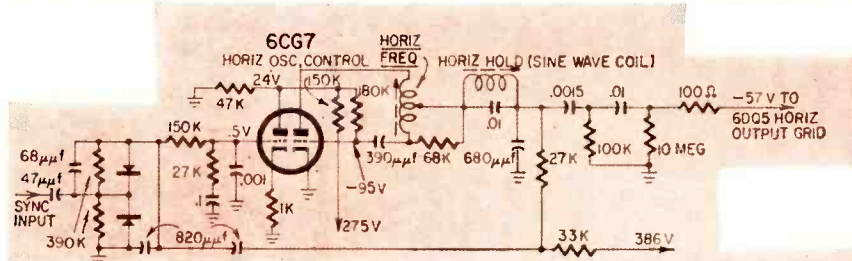

Fig. 26—RCA's color sets use Synchroguide horizontal oscillator with phase detector diodes instead of pulse-width afc system. Plate voltage of left-hand section of tube rises and falls to control oscillator grid bias and frequency.

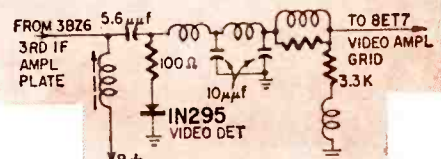

Fig. 27—Sylvania sets have shunt-type video detector circuit.

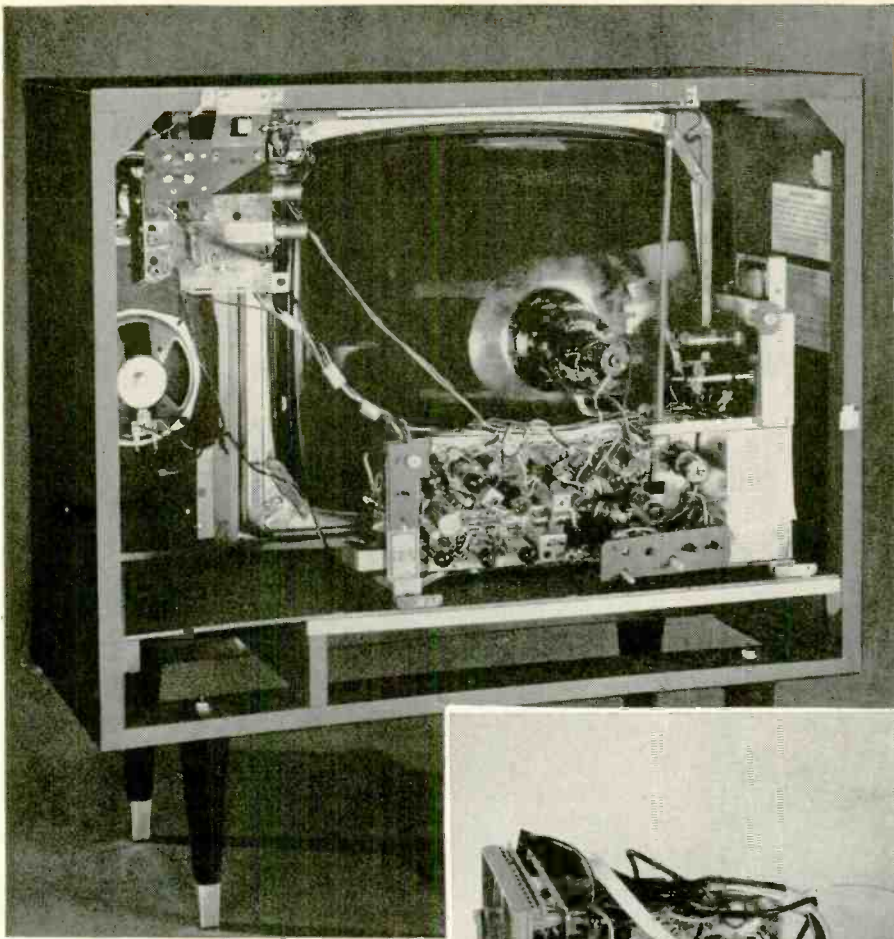
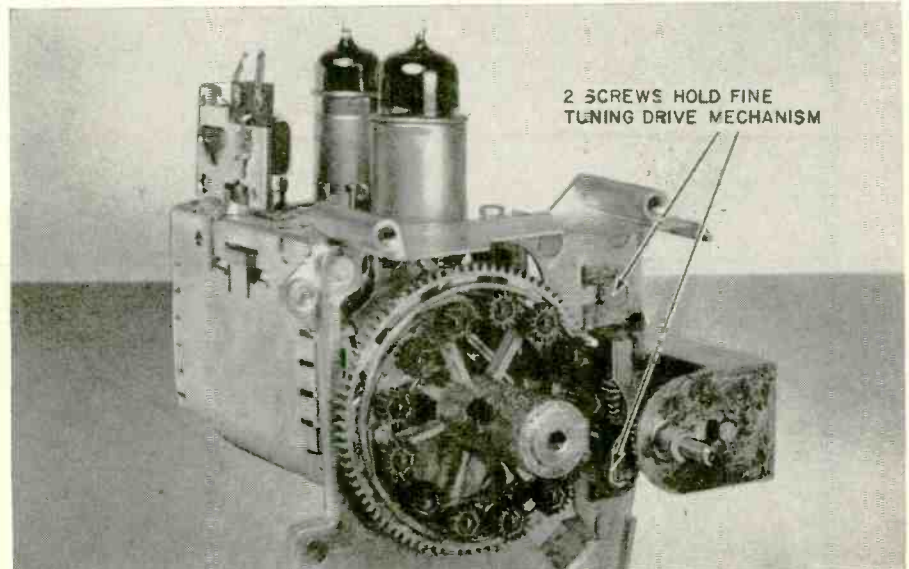
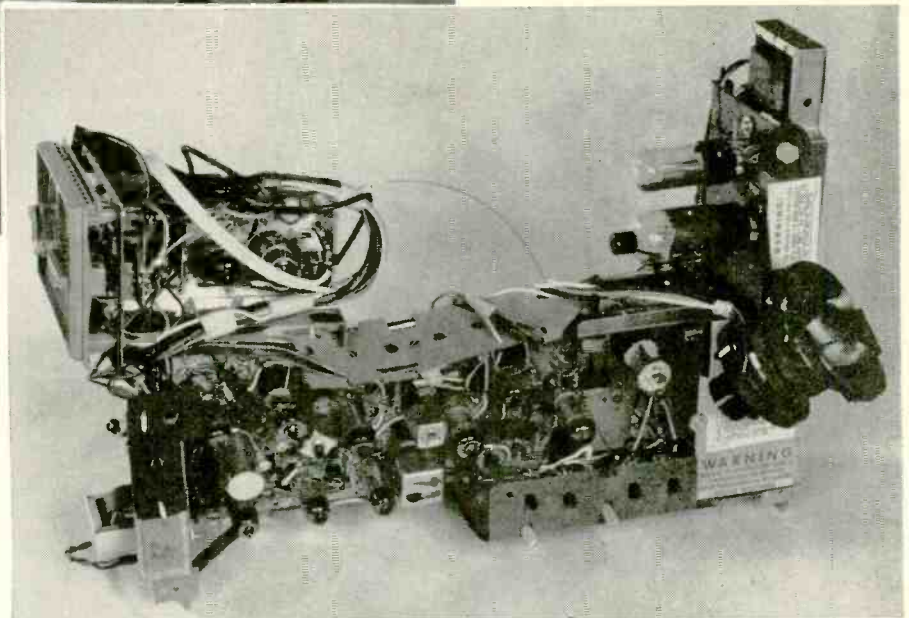

Fig. 28—Sylvania chassis mounted in cabinet.

Fig. 29—Same chassis clipped together for trip to shop for service.



the heater circuit but do have a circuit breaker in series with the voltage-doubler power supply rather than a fusible resistor.

Selenium-diode phase detectors control the horizontal multivibrator. Westinghouse sets have printed circuits and utilize their "See-Matic" board which has all parts symbols, values and connecting points printed right on it. (See "Circuit Boards Are Getting Better" in the December, 1959, issue.)

The portable sets, which incidentally are also built for Montgomery Ward and labeled Airline, can be serviced on the under side by tilting the picture tube out to expose the printed panel.

The fine-tuning gear drive mechanism (Fig. 30) permits individual fine-tuning adjustment for each channel from the front of transformer-powered sets.

Two wireless remotes are available on Westinghouse sets. One is a two-button "hammer-and-rod" type that changes channels in sequence, turns the set off or on and controls the volume in three steps. A four-button remote has a transistorized transmitter that sends modulated and unmodulated signals at 39 and 41 kc. With the four-button remote, volume can be turned either up or down, or channels may be selected in either direction.

Incidentally, on Westinghouse portables you'll find the height and linearity controls under the channel-selector knob.

Zenith

All 1961 Zenith chassis use power

Fig. 30—Westinghouse's "memory" fine-tuning mechanism.

Because of the detailed and extensive coverage of new television trends in this article, we have been unable to print any more television material in this issue. The TV Service Clinic has therefore been omitted. We promise you an extra fat Clinic next month as compensation.

measure V-R TUBE current

THE next time you use voltage-regulator tubes (VR105, VR150, etc.) try this stunt. Instead of connecting the cathode of the bottom tube to ground, insert a 100-ohm ½-watt resistor between cathode and ground. Now you have a method of monitoring the current through the tube (or tubes) without unsoldering leads, pulling out other tubes or anything else. Nor do you have to open any leads and insert a milliammeter. All you do is connect your voltmeter across the 100-ohm resistor and read the voltage. By Ohm's law, if there is 2 volts across the resistor, the current through it is 20 ma. If the voltage is 1.8 the current is 18 ma. Moving the decimal point one place to the right converts the voltage reading to current in mills.

This is a convenient thing to have in a circuit if you make changes later, as it is never necessary to unsolder anything to check current through the V-R tubes. Besides, a stranded wire

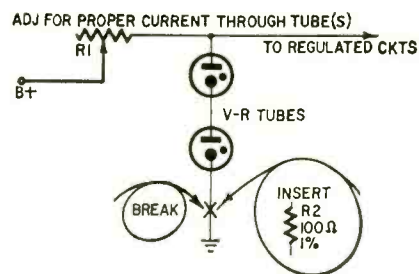

with the usual plastic insulation begins to look a bit shaggy after it has been soldered and unsoldered a time or two. My method is also convenient for setting up the proper operating conditions in the first place. Just connect a voltmeter across the 100-ohm resistor and adjust R1 for the desired current. As a rule, I do this by temporarily hooking up a wirewound potentiometer in place of R1 and adjusting it, then I replace the pot with a fixed resistor of the proper resistance. As often as not, this turns out to be a wirewound adjustable unit to permit changing its value in the event of other circuit changes.

When using the metering resistor, regulation will drop a little from perfection, as a change in current through the 100-ohm resistor varies the circuit voltage by the same amount as the change in voltage across the resistor itself. This will be insignificant except in a very few laboratory applications. The total regulated voltage is also just a little higher than before, but the extra volt or two is not too important, and the simplicity of making measurements and adjustments outweighs the small disadvantages.—*Elmer J. Kaping*

transformers and are hand-wired. All except portables have fuses in the primary circuit of the power transformer. Portables have 700-ma fuses in the center-tap ground-return lead of the power-transformer secondary. All chassis use tube rectifiers. A new rectifier tube, the 3DG4, is used in some chassis. A 5V3 may be used as a replacement if the 3DG4 is unavailable.

Zenith sets for '61 have 17-, 19-, 21- and 23-inch picture tubes. One chassis uses a 23ANP4 CRT with 22 kv on the second anode. In fact, Zenith is the only 1961 set we found that listed as much as 20 kv (on their schematics) measured at the high-voltage rectifier, although some other manufacturers do advertise chassis running up to 23 kv.

Other tube types we noted in the 1961 chassis include a 6CQ4 damper which may be replaced by a 6AX4-GTB, and a 1AU3 high-voltage rectifier similar to the 1J3. A 6EA7 or 6EM7 (interchangeable) is used as vertical oscillator output; a 6GH8, similar to the 6U8 or 6EA8, is used as a horizontal oscillator and control. A 6GN8, similar to the 6AU8 or 6AW8, is used as combination video amplifier and triode sound limiter.

An unusual horizontal retrace-blanking circuit is used in some models (Fig. 31). A blanking pulse taken from a winding on the flyback is fed through a neon lamp to the control grid of the

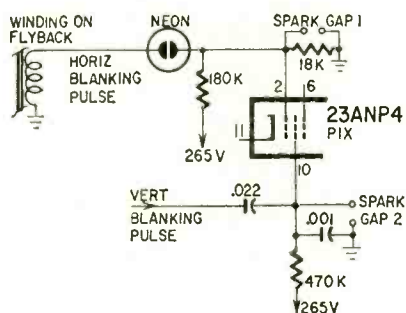

Fig. 31—Zenith's horizontal and vertical blanking circuit. Spark gaps protect other circuits against shorts in CRT.

picture tube. The neon will break down and pass the strong blanking pulse generated during flyback time. However, transients that occur during trace time are blocked because they are not strong enough to ionize the gas. Vertical retrace blanking is applied to the picture tube's first anode.

Spark gaps protect other circuits should a short occur in the picture-tube gun. Spark gap 1 (Fig. 31) slips over pins 1 and 2 of the picture tube. If the picture tube is replaced, it should be installed on the new tube.

The 19-inch Zenith portables have a removable bottom plate, Fig. 32, so that major repairs may be made without pulling the chassis. END

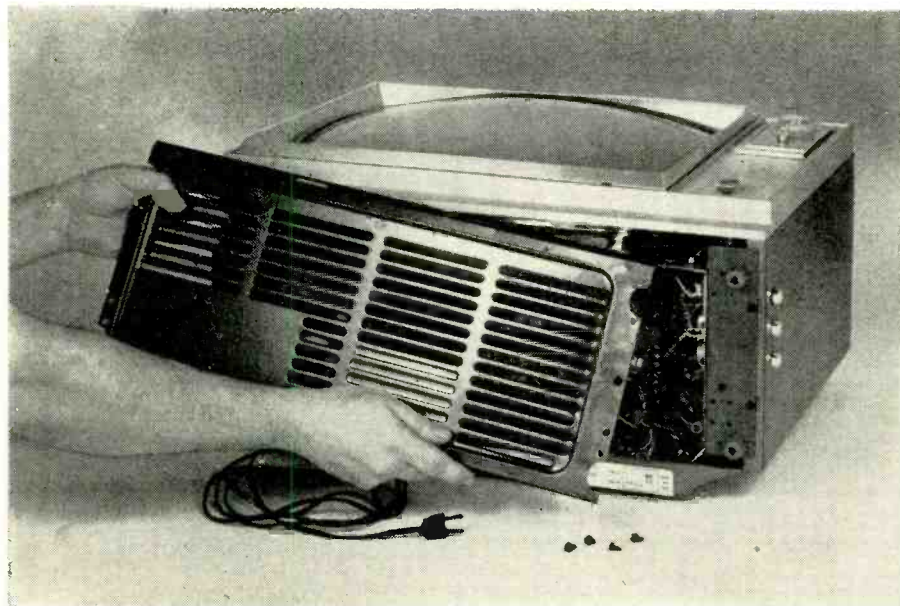

Fig. 32—The "works" in Zenith's 19-inch portables are reached by removing bottom plate.

handie-talkie

COVERS THE 10-METER BAND

Portable unit can be built in sections—transmitter, receiver, modulator, power and control

By
**LEONARD J.
D'AIRO***
K2CDS



SINCE the FCC allocated the 11-meter band to the Citizens Radio Service, many heretofore indifferent citizens have had a sampling of the thrills and excitement of personal communications. Because of this, many Citizens banders have migrated from the Citizens Radio Service to amateur radio, the ultimate in personal communications pleasure. Taking advantage of this increase in the amateur population, many of the major manufacturers of electronic equipment are now producing transmitters and receivers to entice the new and potential radio amateur. Though there are many units to choose from, some persons still prefer to build their own or some are limited financially. Whatever the case may be, this walkie-talkie fills the bill.

* Author, *Servicing Transistor Radios*, Gernsback Library.

Built into a 5 x 3 x 10-inch aluminum chassis that serves as its case, the transceiver is completely self-contained. Transistors are used in the receiver and audio sections and tubes in the transmitter section. Power is supplied by subminiature storage batteries of the type used to power Radio-Sondes sent aloft with weather balloons.

The range of the set, using a 38-inch base-loaded whip antenna, is approximately 10 miles. Using a three-element beam antenna, successful communications have been made over much greater distances.

The transmitter

The unit is not a typical transceiver where one tube is used for both the transmitter and receiver. The transmitter and receiver are separate units, sharing only a common audio system.

This arrangement helps avoid the complex switching often found in single-tube transceivers.

A 6C4 triode is used as a 28-mc oscillator (Fig. 1). It drives a 6AK6 rf power amplifier. Input power to the 6AK6 is about 5 watts. An International Crystal Co. type FM-1 third-overtone crystal is used to fix the operating frequency. This type is used for its small size, its exceptional calibration tolerance (.0025%) and its temperature stability (.005%).

The 6C4 and 6AK6 are used instead of filamentary types like the 3A4 or 3A5 mainly for their power-handling capabilities. Also, because the receiver and audio sections operate at 12 volts, the heaters of these tubes can be connected in series to operate from the same supply. This eliminates the need for a filament dropping resistor, extra batteries or other complex circuitry. A spst toggle switch connected in series with the heater line turns the heaters off when listening only. This reduces battery drain.

The oscillator tank coil is tuned to the high side of the crystal frequency. Oscillations occur because of the feedback provided by the grid-plate capacitance within the 6C4. The output of this stage is coupled to the 6AK6 through a 47- μ f capacitor. The oscillator coil is mounted below the chassis while the final tank coil is mounted above the chassis. This setup prevents spurious oscillations in the final amplifier, since it is operating straight through. It also helps eliminate the need for neutralization. The slightest amount of coupling between the two coils would cause these unwanted oscillations.

Suppressor-grid modulation instead of plate modulation is used on the 6AK6. Since the suppressor grid draws no current, the modulator is not required to furnish any power. Therefore, a voltage amplifier can be used as the modulator, avoiding complex audio circuitry and reducing power drain.

Rf energy from the final tank coil is coupled to the antenna through a three-turn link coil. The cold end of the link goes to ground through a 7-45- μ f ceramic trimmer capacitor. It balances out any capacitive reactance in the antenna circuit. The hot end of the link goes direct to an antenna changeover relay. This is used to minimize rf loss, which would be high if a rotary or other type switch were used for changeover. The relay is in the plate circuit of the oscillator tube. It and R2 form a voltage dropping network to bring the

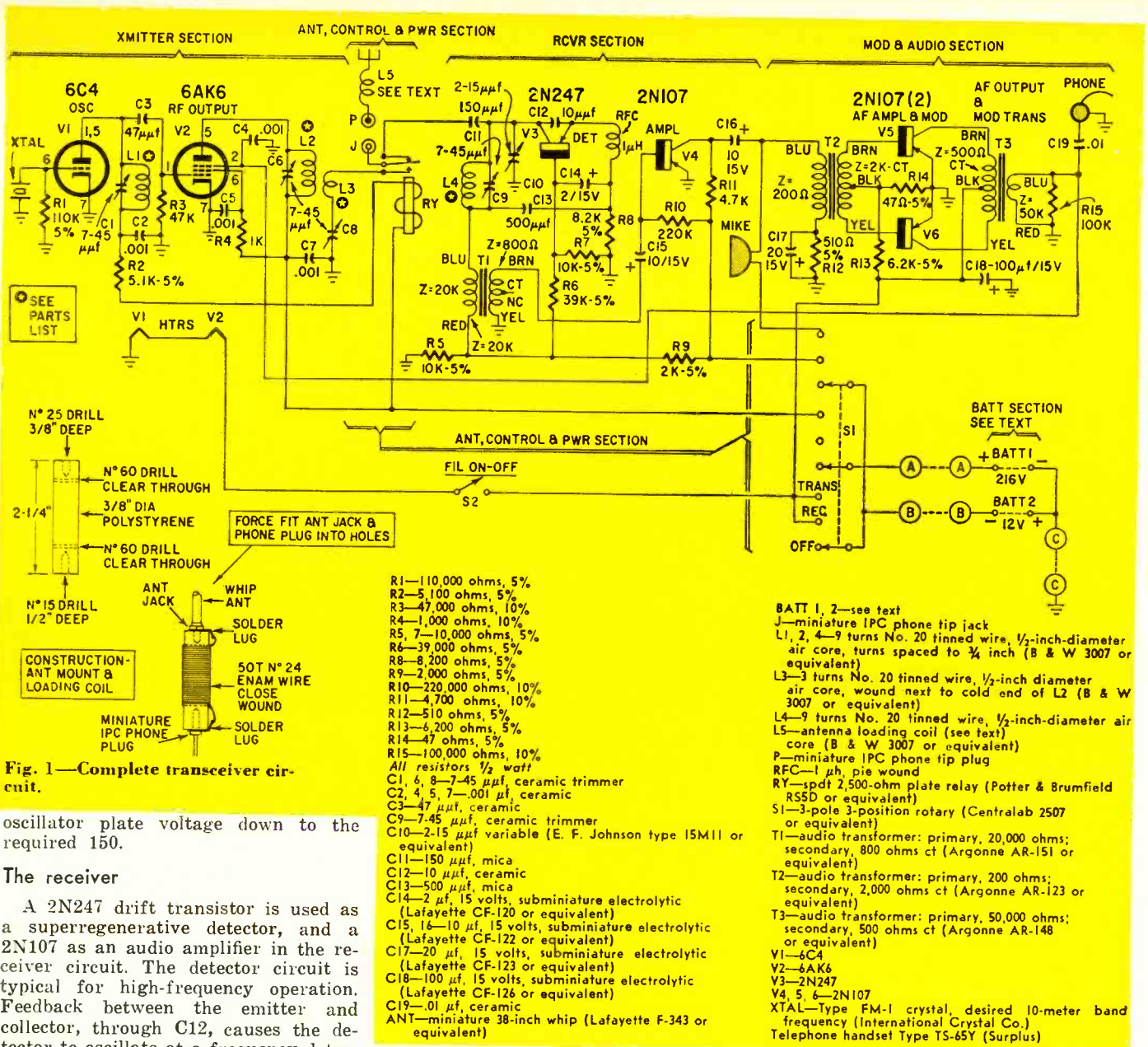

oscillator plate voltage down to the required 150.

The receiver

A 2N247 drift transistor is used as a superregenerative detector, and a 2N107 as an audio amplifier in the receiver circuit. The detector circuit is typical for high-frequency operation. Feedback between the emitter and collector, through C12, causes the detector to oscillate at a frequency determined by capacitors C9 and C10 and coil L4. Although the 10-meter band is 1.7-mc wide, no regeneration control is used because the design of the detector enables it to operate smoothly over this range. The values of the components were chosen for optimum detector operation over this range. If a regeneration control is needed, it can be substituted for R8.

Audio voltage is developed across T1's primary and is coupled to the base of the 2N107 through its secondary. Because the output impedance of the detector collector is high (about 20,000 ohms) and the input impedance of the amplifier is low (500 ohms), transformer coupling must be used for proper impedance matching and maximum transfer of the audio signal. R-C coupling was tried, but the value of C had to be high to get good audio transfer. This had the effect of loading the collector output to a point where the detector became quite insensitive to small signals.

The antenna is coupled through a 150- μ f capacitor to the collector of the



Close up of the Handie-Talkie's front panel.

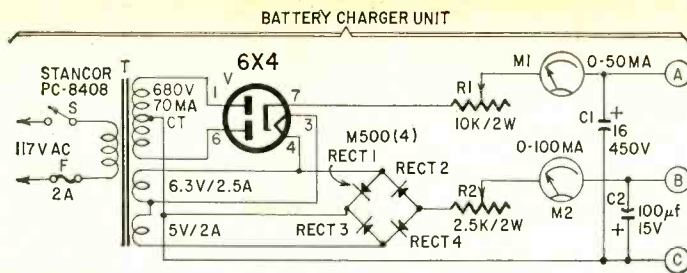

- R1—pot, 10,000 ohms, 2 watts
- R2—pot, 2,500 ohms, 2 watts
- C1—16 μf, 450 volts, electrolytic
- C2—100 μf, 15 volts, electrolytic
- F—2 amps
- M1—0-50 ma
- M2—0-100 ma
- RECT 1, 2, 3, 4—M500 (Sarkes-Tarzian)
- S—spst toggle
- T—power transformer: primary 117 volts; secondary, 680 volts ct, 70 ma; 6.3 volts, 2.5 amps; 5 volts, 2 amps (Stancor PC-8408 or equivalent)
- V—6X4

Fig. 2—Battery recharger for the Handie-Talkie.

2N247. The capacitor reduces the loading effect of the antenna. Capacitor C9 sets the detector's operating frequency while C10 is used for bandspreading.

Receiver sensitivity is better than 2 μV per meter for a 50-mw power output at the earphone. Reradiation from the detector is noticeable only up to about 100 feet because of the lower power at which it operates.

The audio section

Two 2N107's are used in a push-pull class-B audio amplifier circuit. Idling current is 2.5 ma, 1.4 ma of which flows through the base biasing resistors R12 and R13. Under peak audio signal, the amplifier draws up to 25 ma, delivering close to 150 mw of audio power. Although this amount of power is not required to modulate the 6AK6, at least 50 mw of audio is needed to drive the earpiece of the handset to a comfortable listening level.

The modulation transformer, T3, is a miniature driver transformer connected backward. The secondary winding is the primary or collector load. The high-impedance primary is used as the modulation winding. It is loaded with a 100,000-ohm resistor to present a constant load to the 2N107's in the transmit and receive positions. The audio voltage developed across the resistor is more than enough to modulate the 6AK6 and drive the earphone.

Current for the microphone is obtained from the 12-volt battery through an R-C network. The resistor limits current through the microphone and keeps the modulator from being over-driven.

Power and control

A three-pole three-position rotary switch controls the unit (S1). When it is in the OFF position, all power is removed from the circuits. In the REC position, 12 volts is applied to the receiver, modulator and tube heaters. Switch S2 turns the tube heaters off when the receiver is used for listening only. In the TRANS position, power is removed from the receiver only and 216 volts is applied to the plates of the transmitting tubes. Power is continuously applied to the modulator in the REC and TRANS positions since this unit is common to the transmitter and receiver.

As mentioned at the beginning of this article, power is obtained from subminiature storage batteries. Two 6-volt batteries connected in series supply 12 volts for the receiver, modulator, microphone and tube heaters. These batteries can deliver 200 ma continuously for 3 hours. Maximum current drain in the

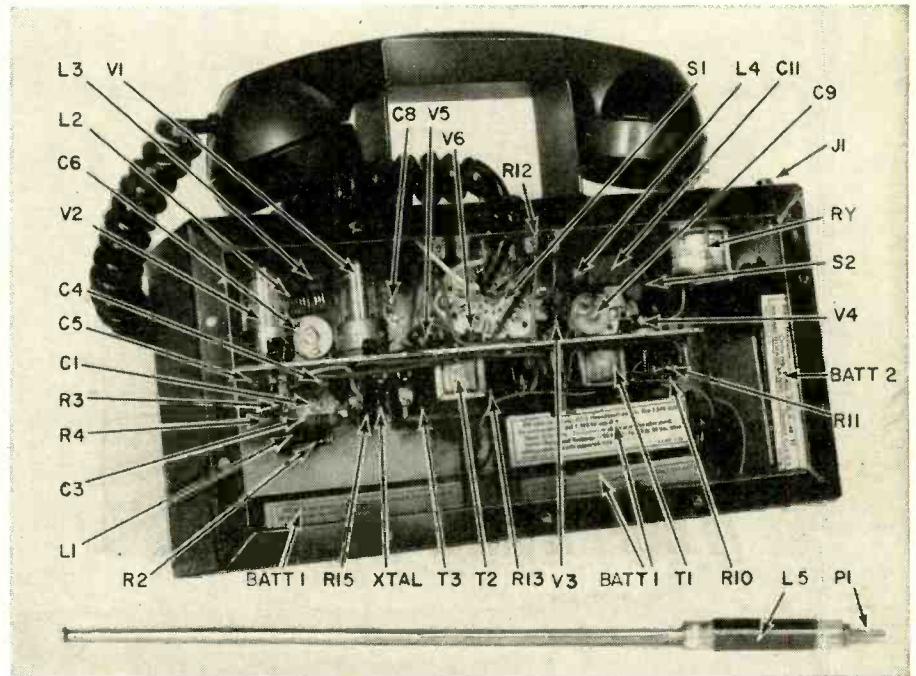

Internal view shows compact parts arrangement.

REC position is 160 ma; in the TRANS position, 175 ma.

Six 36-volt batteries are connected in series to supply 216 volts to the transmitter. Maximum current drain during a transmission is 28 ma. The batteries can deliver 30 ma continuously for 3 hours.

These subminiature storage batteries were chosen for four good reasons:

- ▶ Small size: Each battery measures 3% x 1% x 7/8 inches.
- ▶ Power output in relation to size.
- ▶ Ability to be recharged. This feature alone saves many dollars in battery replacements alone.
- ▶ Their extremely low cost.

The batteries are surplus, but are new and sealed in an airtight metal container. The cost is \$1.50 per set, which includes one 6-volt and three 36-volt batteries (two sets are required). They are available from the C & H Sales Co., 2176 E. Colorado St., Pasadena 8, Calif. (BB 208 Flash AMT). Complete instructions for filling and charging the batteries are included with each set. The acid can be obtained from any local garage.

A battery charger is shown in Fig. 2. When charging the batteries (charge every 10 days, with or without use), remove them from the transceiver case. During the charge, the electrolysis action that occurs causes some of the acid to bubble out and spill over. If the batteries are charged in the case, the acid will corrode the aluminum case and

will damage other parts as well.

Construction

The transmitter, receiver and modulator are all mounted and wired on an 8 x 2 1/2 x 1/2-inch L-shaped aluminum chassis. It is mounted inside the 5 x 10 x 3 case. The transmitter portion, looking from the rear, is mounted on the left side. The modulator is in the center and the receiver toward the right. The transmit-receive switch and tuning capacitor for the receiver are mounted on aluminum brackets which are mounted on the L-shaped chassis on the receiver side. The heater switch hangs free on the extreme right side. This method of assembly allows the whole works to be removed in one unit.

The antenna changeover relay is mounted in the upper right inside corner of the case. Two 1/2 x 3/8-inch ceramic standoffs are used to insulate the relay from the case. The antenna jack is mounted in the same corner.

In wiring the transmitter and receiver sections, all leads, except power leads, should be as short as possible. Bakelite terminals strips can be used wherever necessary to mount components. The 2N247 detector transistor is wired directly into the circuit on top of the chassis. Sockets are used for the 2N107 transistors. All components, except the final tank coil, detector tank coil and controls, are mounted below the chassis. A short length of insulated shielded wire is used to connect the

final tank link to the relay.

The six 36-volt batteries are wired in pairs and are mounted on the bottom of the case. The two 6-volt batteries are mounted upright on the right hand side of the case, below the relay and antenna jack. Brackets are used to secure the 6-volt and two 36-volt batteries in place. The remaining four 36-volt batteries are stacked and held in place by the others.

The antenna is a 38-inch whip which closes down to 9 inches. It is mounted on a $2\frac{1}{4} \times \frac{3}{8}$ -inch polystyrene rod on which loading coil L5 is wound. In constructing the mount (Fig. 1), drill a $\frac{3}{8}$ -inch-deep hole into one end of the rod, using a No. 25 bit. On the other end, use a No. 15 bit to drill a $\frac{1}{2}$ -inch-deep hole. At the bottom of each hole drill another hole at a right angle to it clear through. Use a No. 60 bit. After the holes are drilled, wind 50 turns of No. 24 enameled copper wire on the rod, threading the ends of the wire through the small holes. Force-fit the jack that comes with the antenna into the No. 25 hole. Place a lug between it and the rod. Solder one end of the loading coil to this lug. Force-fit a miniature IPC phone tip plug into the other hole and place a lug between it and the rod. Solder the other end of the coil to this lug. When the mount is completed,

attach the whip and plug it into the antenna jack on the case.

Final adjustments

Set your signal generator for a 400-cycle tone and 30% modulation for aligning the detector. Plug in the antenna assembly and wrap two turns of hookup wire loosely around it. Connect this wire to the signal generator, and set it to 28 mc. With C10 fully meshed (closed), adjust C9 until the signal is heard in the earphone. The detector is now aligned and C10 should cover the entire 10-meter band from 28.0 to 29.7 mc through 180° rotation. If the detector does not oscillate, reduce the value of C11. It should be between 100 and 220 μf . If the detector still fails to oscillate, check the wiring or replace the 2N247. The detector circuit is so designed that it will oscillate even if the antenna is connected direct to the detector tank coil.

After the receiver is working properly, set capacitors C1 and C6 at midpoint. Connect the dc probe of a vtvm to pin 1 of the 6AK6 and apply power. Adjust C1 for maximum negative voltage. You will notice that as soon as you reach a peak in voltage, the circuit will suddenly stop oscillating. This shows that the oscillator is functioning normally. Adjust C1 to a point just before

this cutoff occurs. To make sure that the oscillator is set properly, turn the transmitter on and off a few times. Each time the transmitter is turned on, the oscillator should start. If not, then readjust C1 until it does. At the same time make sure that the relay closes when the oscillator is turned on. If the relay is sluggish, decrease the value of R2 to 3,900 ohms. If the relay snaps loudly, increase the value of R2 to 5,100 ohms.

Next, connect the dummy load (a No. 47 pilot lamp) between the antenna jack and chassis and adjust C6 and C8 for maximum brilliance. Disable the oscillator by shorting pin 6 of the 6C4 to ground. The bulb should go out. If it remains lit, the final amplifier is oscillating. The tank coils should be re-oriented until the stage stops oscillating. A small negative voltage applied to the suppressor grid may help stop this oscillation. The proper value is determined by experimenting.

After the final stage is adjusted, remove the dummy load and insert the antenna. Using a grid-dip oscillator as a field-strength meter, readjust C6 and C8 alternately for maximum rf output. If a grid-dip oscillator is not available, just hang the vtvm's ac lead near the antenna and tune up. The Walkie-Talkie is ready for operation! END

TRANSFORMER IN A LINE PLUG

By MILTON WHITE

COMMERCIAL fittings for connecting small power transformers direct to power lines are not available. Here is a cheap and easy method, using an ordinary line attachment cap and a Muller No. 26 insulator that makes a first-class mounting for transformers with cores that are not more than $\frac{3}{8}$ inch wide, the limit set by the maximum allowable width of the slot (C in Fig. 1).

Cut down a rubber line attachment cap to the form shown in Fig. 1, making the width of slot C a loose fit to the transformer core and the length of the slot at a right angle to the contact prongs (D). Expose the back ends of the screws holding the contact prongs to the body of the attachment cap (not the line connecting screws) by countersinking with a knife (a regular countersink just won't work here). These screws and countersinks are at A and B in Fig. 1. Solder the transformer's pri-

mary leads to the exposed screw ends. Put a thick coat of cement in the slot and set the transformer in place.

Splice the required length of lamp cord to the transformer's secondary leads. Tuck these splices and any slack in the primary leads into the corners formed between the transformer coils and the core. Tie a knot in the lamp cord over the top of the transformer to act as a strain relief.

Grease the outside of a Muller No. 26 insulator with Vaseline, then turn it inside out. Put a coat of cement around the line attachment cap, slip the lamp cord through the insulator (see Fig. 2), then roll the insulator back over the cap and transformer assembly.

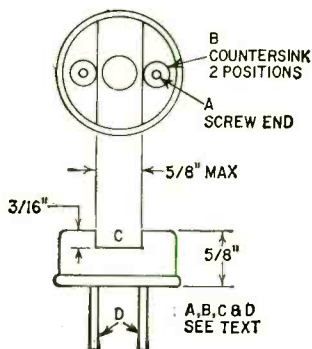

Figure 1



Figure 2

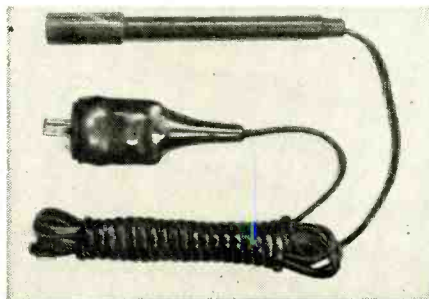

Figure 3

The finished job is shown in Fig. 3, together with an excellent trouble light, a device for which the assembly described is ideal.

Fig. 4 details the construction of the trouble light, except for the position of the single turn of wire. This wire acts as a friction lock for the light shield. It is adjusted along the lamp socket so that the shield locks in the position shown. To lock the shield, pull it forward with a twisting motion. It locks securely, so it cannot be pushed straight back by hand. To release the lock, just reverse the locking action, push the shield back with a twist. END

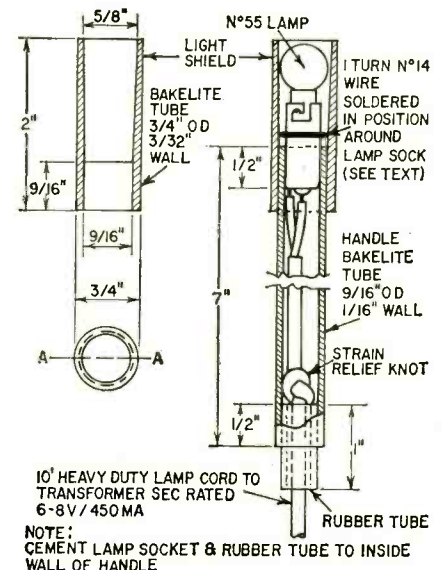

Figure 4

NOTE: CEMENT LAMP SOCKET & RUBBER TUBE TO INSIDE WALL OF HANDLE

and now —

THE TRANSISTORIZED PORTABLE SCOPE

**Using almost no tubes,
this industrial unit can
be powered by an external
ac or dc source, or it can
use built-in batteries**



By TOM JASKI

It seems that we have been waiting a long time for the transistor to fulfill all our hopes and provide us with light, portable devices of all kinds. The portable transistor TV is with us, but not so easy to come by. Now Tektronix breaks another barrier by producing the all-transistor (well, nearly all) portable oscilloscope. "Nearly all" because there are two tubes in the scope, besides the CRT, to do jobs which transistors could not do well enough. One tube is the vertical input amplifier and the other is the high-voltage supply rectifier. However, these two tubes do not materially affect battery life and they certainly do not change the scope's portability.

As a result the scope can compete specification-wise with high-quality tube models. Bandwidth is dc to 5 mc with a rise time of .07 μ sec. Deflection sensitivity is variable from 10 mv to 20 volts per division (cm) in 11 calibrated steps in a 1-2-5 (10 mv, 20 mv, 50 mv, . . .) sequence. Sweep ranges from 0.5 μ sec per division to 0.5 second per division (5 seconds to sweep across the tube face). The sweep circuit has 19 calibrated steps, also in the 1-2-5 sequence.

The scope incorporates a calibrator for precise voltage comparison, weighs 17 pounds complete with batteries and measures 8 $\frac{3}{4}$ x 5 $\frac{3}{4}$ x 16 inches. What more can you ask for!! The model 321 costs approximately \$775 (not including batteries) and rechargeable batteries are available at extra cost. So is a charger, that can be built into the instrument. But 10 size-D flashlight cells will also operate the scope, as will 117 or 220 volts ac, 50 to 800 cycles. This means that the scope can be plugged directly into a 400-cycle aircraft supply. Also 11.5 and 35 volts dc can be used (you can plug the instrument into an automobile, boat, railway, or farm dc power system). Just about as versatile as can be.

This is, of course, part of the beauty of this scope. It can be used on practically any power source or *none at all*, making it useful where before no scope could be operated. Examples are: troubleshooting and repair jobs on boats, small planes, railway work, "on location" and experimental work in inaccessible or difficult places, all kinds of applications where a scope would ordinarily either require carrying a

bulky converter or running a power cord for long distances. Let us see what it takes in the way of circuitry to get this kind of performance.

Circuitry

Fig. 1 shows the block diagram. Tektronix engineers did not get tricky; it is pretty conventional except for the oscillator low-voltage supply, which is built along the lines of the usual scope or portable TV high-voltage supply.

Vertical amplifier

Fig. 2 shows part of the vertical amplifier (and calibrator). This has first a standard attenuator, then the 5718 input amplifier, one of the two tubes used in the scope. This triode, used in a cathode-follower circuit, was used to obtain the high-impedance input, stability (stabilized heater supply) and wide-band response desired. After the 5718 the amplifier consists of alternate emitter followers and amplifiers, using a number of 0C170's. The 0C170 is a European transistor, used because of its high gain, low leakage and high voltage tolerance. It is a drift transistor.

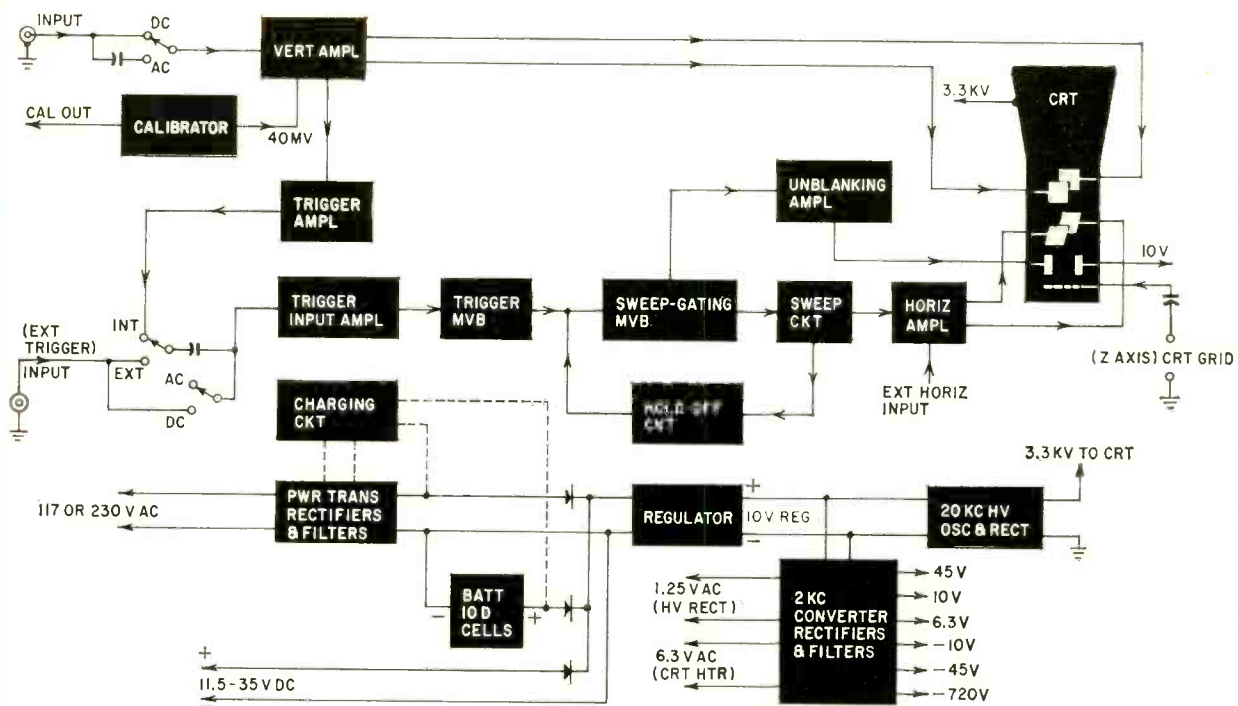

Fig. 1—Block diagram of Tektronix 321 oscilloscope.

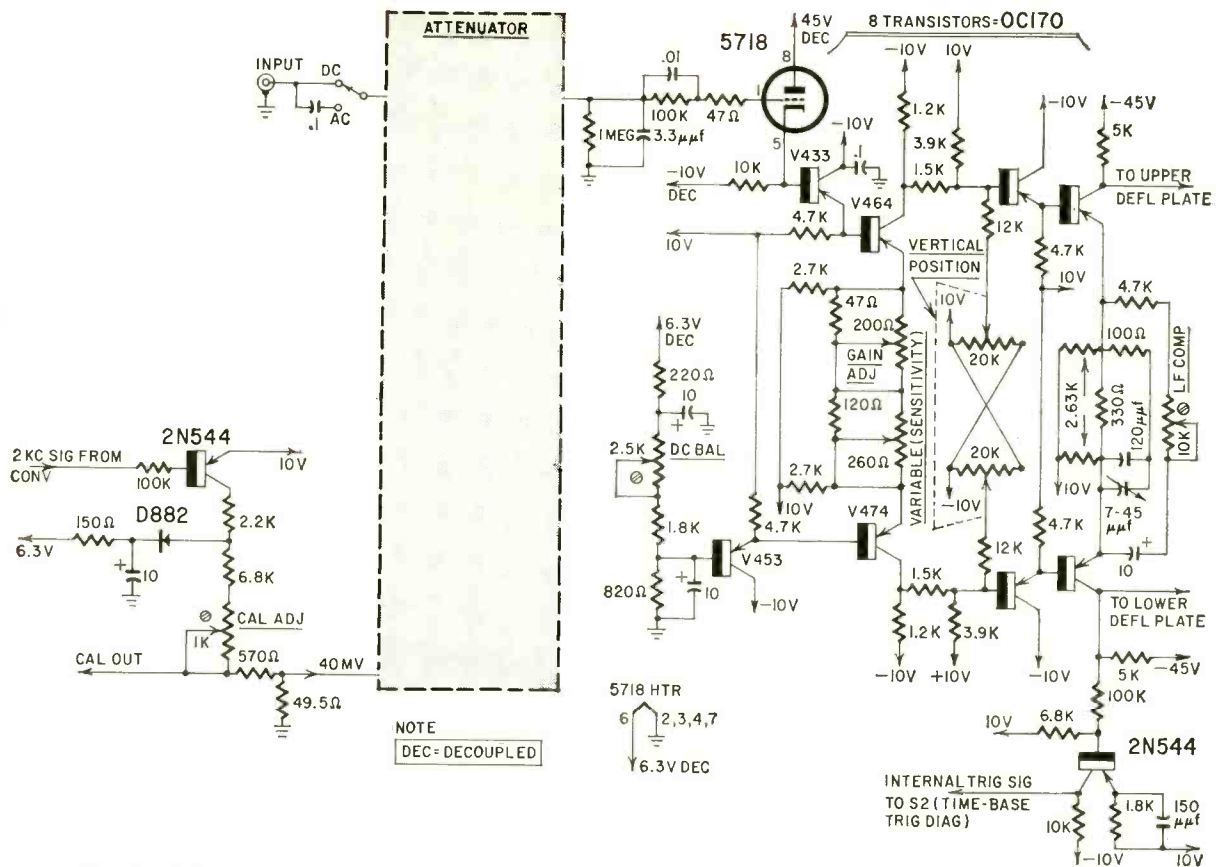

Fig. 2—Schematic of vertical amplifier and calibrator. Step type attenuator has 11 positions.



Because it has its own power supply, the scope may be used in servicing small-plane equipment.

The amplifier is completely balanced to minimize temperature effects and to obtain push-pull deflection. Vertical position is adjusted by changing the bias on the last set of emitter followers. V453 receives no signal. It serves to balance the bias on V474 against that on V464. These last two transistors form a common emitter resistor-coupled stage. The trigger takeoff amplifier is shown on the right, and on the left we see the calibrator. This is an overdriven amplifier which obtains the calibration signal (2 kc) from the converter in the low-voltage power supply.

Horizontal amplifier

The horizontal amplifier is not unusual. It consists of a set of emitter followers and a pair of amplifiers (somewhat similar to the output sections of the vertical amplifier). These are again balanced to obtain push-pull deflection and minimize temperature effects. Horizontal sensitivity is not great (1.5 volts per division maximum). In the emitter-bias circuit of the output stage a switch is used to obtain five-times-normal sweep width by effectively reducing the emitter series resistance.

The trigger amplifier (Fig. 3) is a balanced common-emitter amplifier. It can reverse trigger-signal polarity when desired. The trigger multivibrator, which shapes the trigger for the sweep circuit, is a transistor version of the well known Schmitt circuit. The trigger pulse is applied to the sweep-gating multivibrator (Fig. 4), which is also a Schmitt circuit but with a large voltage differential between the "on" and "off" triggers. This circuit holds the gate open (nonconducting) for the duration of the sweep. The "gate" is the normally conducting (closed) V153, which prevents the timing capacitor from charging.

Sweep circuit

Initially the timing capacitor (C160) is discharged, allowing a positive voltage at the base of emitter follower V163. A negative output from the Schmitt cuts down the conductivity of V153, allowing the capacitor to charge. This creates a voltage drop across the

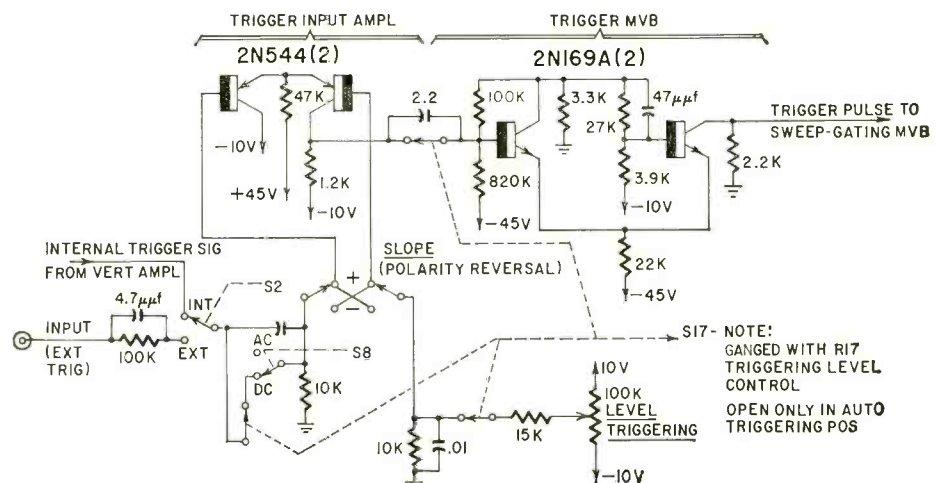

Fig. 3—Trigger-amplifier and multivibrator circuit.

timing resistor (R160), lowering the voltage on the base of V163. V161 amplifies this change in signal, and it is applied to the horizontal amplifier through another follower, V173. But the signal is also applied to the collector of V153 and, when the charging rate of the capacitor increases, V153 will conduct more heavily and thus reduce the charging rate. In this way charging of the capacitor is kept perfectly linear. S160 selects different values for R160 and C160 to get the desired sweep rate.

A portion of the sweep signal is also applied to the base of V183, the holdoff transistor. This transistor is normally conducting, holding C180 (holdoff timing capacitor) discharged. When the sweep signal is applied to V183, the capacitor begins to charge, raising the voltage on the base of V135. The Schmitt circuit changes state and once again can accept trigger pulses. When the gate closes (V153 conducts), timing capacitor C160 discharges through D153.

Unblanking

The cathode-ray tube in this instrument is a special type, containing a second set of horizontal deflection plates (above G1 in Fig. 5). One is connected to 10 volts, the other to the unblanking amplifier. Between sweeps, the unblanking plate is held at -20 volts. The beam is deflected off-screen and is not visible until a positive pulse voltage is applied to the unblanking deflection plate. A special overdriven blanking amplifier (V194, Fig. 4) provides the unblanking voltage with ultra-rapid rise time. V199 is a voltage regulator



Using scope to check out depth indicator.

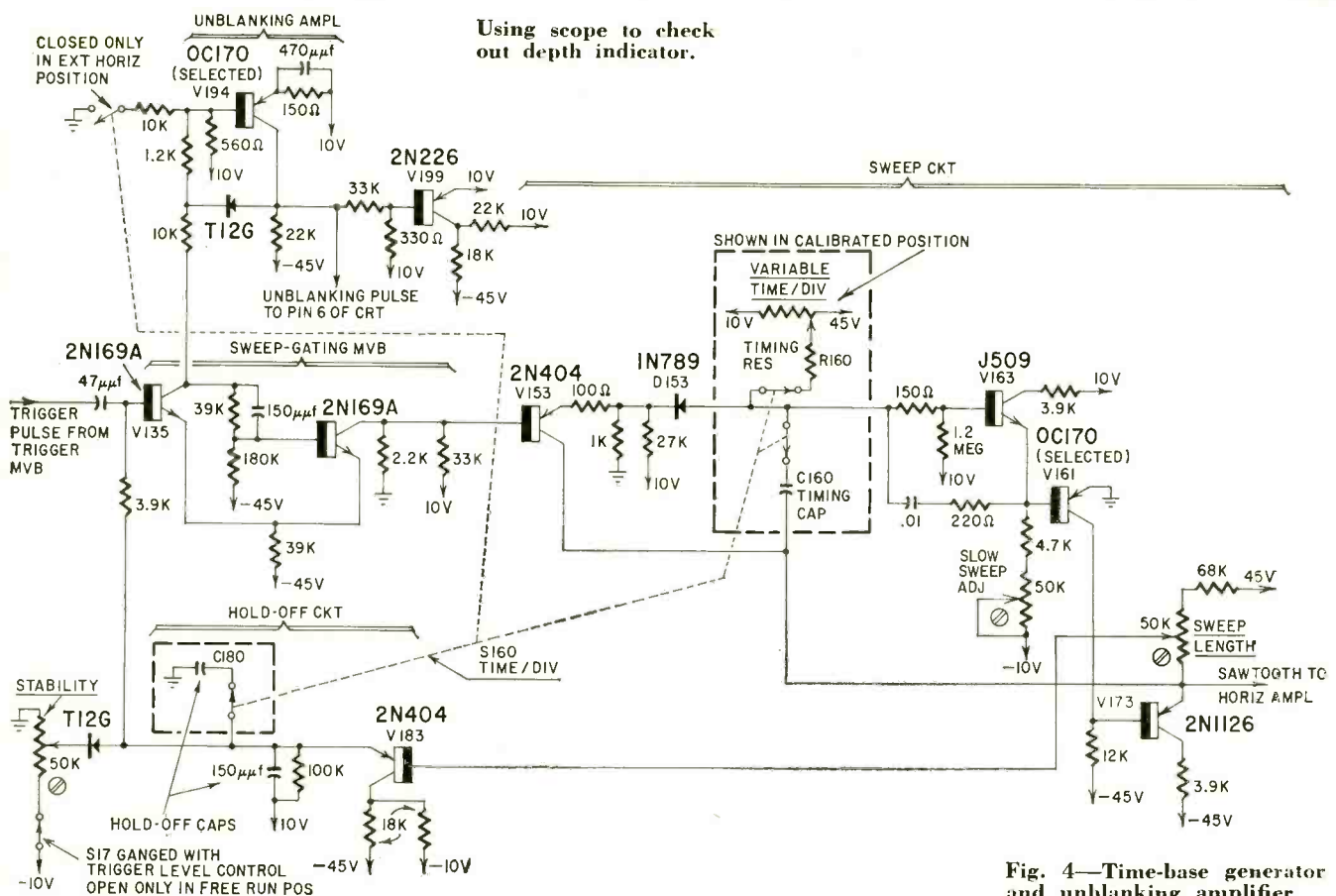

Fig. 4—Time-base generator and unblanking amplifier.

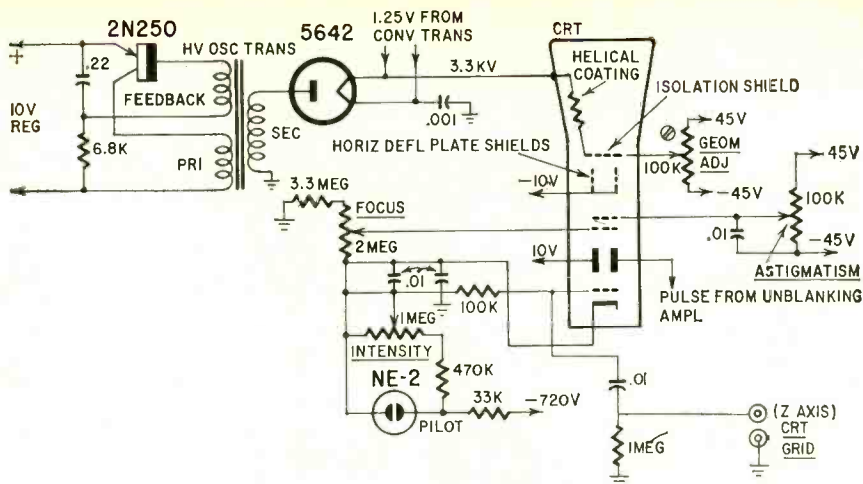

Fig. 5—Connections to cathode-ray tube. 20-kc oscillator and rectifier supplies high voltage. Standard deflection plates are not shown.

for the amplifier. The unblanking signal puts the beam back on the screen during scanning.

The low-voltage power converter is conventional and resembles the often published "transistor power supply." Operating frequency is 2 kc (the high-voltage supply operates at 20 kc). Note

that voltage regulation takes place before the converter (Fig. 1). In this manner voltage supplied by the 117-volt ac circuits is regulated as well as the dc input voltages. In other words, whether the scope is being supplied from its own batteries, from an outside dc source or from the ac line, the con-

verter and regulator are always operative. This makes for the least difference in the various modes of operation, as far as the amplifier and sweep circuits are concerned. The battery charger is optional. It has a current regulator with a temperature-sensing bridge. The temperature of the battery is proportional to the charging rate. Maintaining an even charging rate is important with the small rechargeable batteries used, and the regulator measures the temperature rise above ambient.

There you have it, a new instrument which, in spite of its price, is going to gain enormous popularity because of its portability, versatility and ease of operation. There is no sacrifice in performance for portability, and the 321 will do any job as well as most service type scopes, and perhaps a little better. It is no match for the very-high-performance types also made by Tektronix, but then it was never meant to be. And apart from the rather special CRT, the designers did not have to resort to tricks to get the response required, just good sensible design. This is a first in the scope business, and a step in the right direction to fulfill the promise of the transistor. **END**

PROTECT that Voltage Regulator

ALL voltage regulators and transistor versions in particular should be protected against overloads. After all, too much current through a regulator transistor and several dollars go down the drain. Some circuits recently appeared in a Texas Instruments *Application Note* (July, 1960) on using a backward diode to protect regulator circuits.

A basic circuit using a backward diode, an auxiliary transistor and two resistors to protect a voltage regulator (V2) is shown in Fig. 1. During normal regulator operation, the voltage across R1 keeps the diode from conducting and V1 operates in saturation. Thus the series control element—the collector-emitter element of V2—sees V1 as a low impedance. However, when load current becomes excessive, the diode starts to conduct in the reverse direction because of the additional voltage drop across R1. This reduces the base-emitter voltage of V1 which reduces collector current to a safe figure.

Fig. 2 is a working regulator using the protective circuit shown in Fig. 1. It demonstrates the current-limiting technique of overload protection. This circuit causes little deterioration in

normal regulator performance although the saturation resistance of V1 and the resistance of R1 make the output resistance somewhat higher. Also, changes in operating temperature can shift the current level at which limiting occurs. Temperature effects can be reduced, however, by careful selection of components. Fig. 2 is set up with control R1 adjusted so current regulating starts whenever the load current exceeds 500 ma. As Fig. 3 indicates, current limiting with this circuit is very sharp once the maximum allowable load current is exceeded.

This circuit has one important disadvantage—V1 must withstand both the maximum load current and a voltage nearly equal to the unregulated input while a short-circuit load condition exists. This makes it necessary to limit the use of this circuit to low-voltage low-current regulators. But, as higher-voltage higher-power transistors become available, this same protective circuit will apply to higher-power regulators. Until then, cascade the protective circuits if the unregulated supply voltage is greater than the voltage rating of a single transistor. **END**

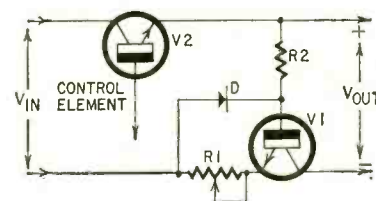

Figure 1.

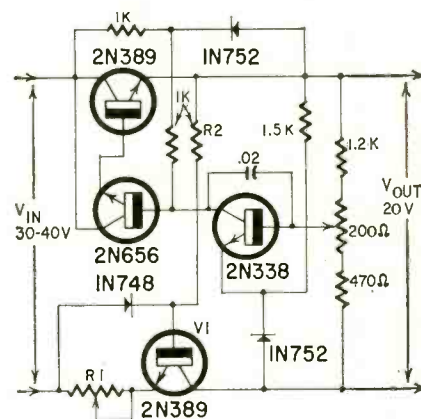

Figure 2.

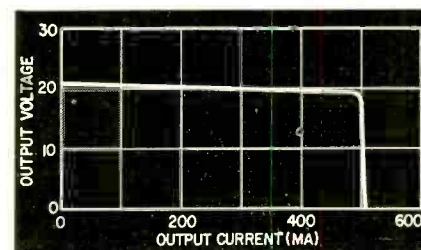
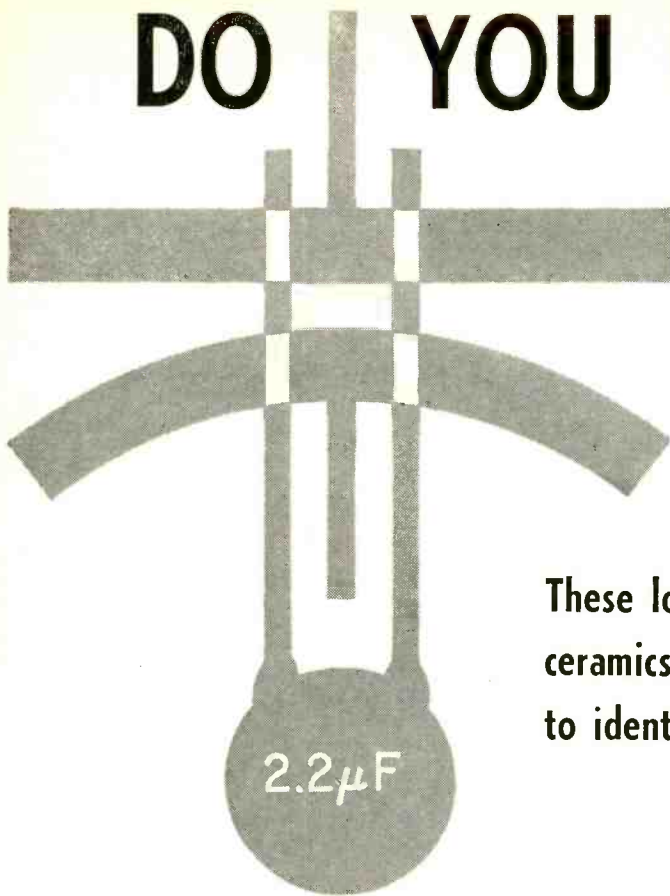

Figure 3.

DO YOU KNOW THE ULTRA-KAP?



These low-voltage high-capacitance ceramics are different. Do you know how to identify and test them?

By Capacitor Engineering Dept.
of Centralab*

A COMPLETELY new type of ceramic capacitor is appearing in various types of electronic equipment. Known as Ultra-Kaps†, these patented units are made of ceramic and have the same appearance as other ceramic disc capacitors. But they are engineered on an entirely different principle. It is important to understand this principle and be able to identify the units because conventional testing techniques and replacement procedures do not apply to these capacitors.

Ultra-Kaps are low-voltage capacitors used only in transistor and similar low-voltage circuits. They provide an extremely high capacitance for their size—50 to 100 times greater than that of standard ceramic units! In other words, from the capacitance standpoint, they are in the electrolytic rather than the usual ceramic capacitor range.

A most unusual aspect of these capacitors is their self-regulating voltage characteristic. This is the major factor in accounting for the inability to use standard testing techniques. The Ultra-Kap is constructed of a material that undergoes a molecular reorientation when an overvoltage is applied to it. This permits the current to flow through the unit, causing the capacitor to operate as a conductor rather than a capacitor. It can be likened to an

*The Electronics Division of Globe-Union Inc.
†Centralab trademark. Similar units are being made available by other manufacturers.

ULTRA-KAP SPECIFICATIONS CAPACITANCE VS. SIZE

Approximate Diameter (inches)	Capacitance (µf)	
	3 VOLTS	10 VOLTS
9/32	0.22	.05
13/32	0.47	0.1
19/32	1.0	0.2
27/32	2.2	0.47

LEAKAGE RESISTANCE 3-VOLT UNITS

Capacitance (µf)	Leakage Resistance—ohms		
	(at 0.5 VDC)	(at 1.5 VDC)	(at 3 VDC)
0.22	500K	50K	2.5K
0.47	350K	35K	1.8K
1.0	300K	30K	1.5K
2.2	30K	7K	0.6K

LEAKAGE RESISTANCE 10-VOLT UNITS

Capacitance (µf)	Leakage Resistance—ohms		
	(at 3 VDC)	(at 9 VDC)	(at 10 VDC)
.05	5 Meg	1 Meg	50K
0.1	5 Meg	1 Meg	50K
0.2	5 Meg	1 Meg	50K
0.47	5 Meg	1 Meg	50K

electronic valve in that the current merely flows through the unit during overvoltage conditions. This temporary condition exists only while the higher voltage is applied. When the voltage is lowered, the unit again operates as a capacitor. Consequently, this capacitor doesn't "short-circuit" as others do when they are overloaded.

The resulting dependability of these units, as well as their exceptionally small size, accounts for their increasing application in radio, TV and hi-fi equipment. There are approximately 7,000,000 Ultra-Kaps in use today, and there have been no known cases of electrical failure on any of them. Based on this experience, it seems likely that any unit requiring replacement is probably a vic-

tim of physical damage rather than electrical failure.

As indicated earlier, the unusual "valve effect" of these units makes it impossible to test them in the usual fashion. Industrially, ceramic disc capacitors are generally tested at twice rated voltage. If this test were applied to one of these new capacitors, the unit would act as though it were shorted, even if it were operating perfectly.

In servicing work, capacitors are usually tested for leakage resistance. However, these units have a relatively low leakage resistance which would mislead the service technician into thinking that a perfectly good unit is defective. So it is important for the technician to know how to identify these units and how to test them.

Identification

As was mentioned previously, Ultra-Kaps are used only in low-voltage circuits. While their main application is in transistorized equipment, they are frequently used in vacuum-tube devices as cathode bypass or interstage coupling capacitors. They are also used in preamplifiers and crossover networks. However, they will never be found in any circuit carrying more than 10 volts.

Physically, they have the same shape and general appearance as any other ceramic disc capacitor. However, the Durez protective coating is *gray-green in color*, and they are much smaller than might be expected for a ceramic disc of such a high capacitance. In fact, no other ceramic discs are made in this capacitance range—.05 µf to 2.2 µf. While it is theoretically possible to build high-capacitance conventional ceramic discs, they would be too large and expensive for any practical application. The table shows the relative size and

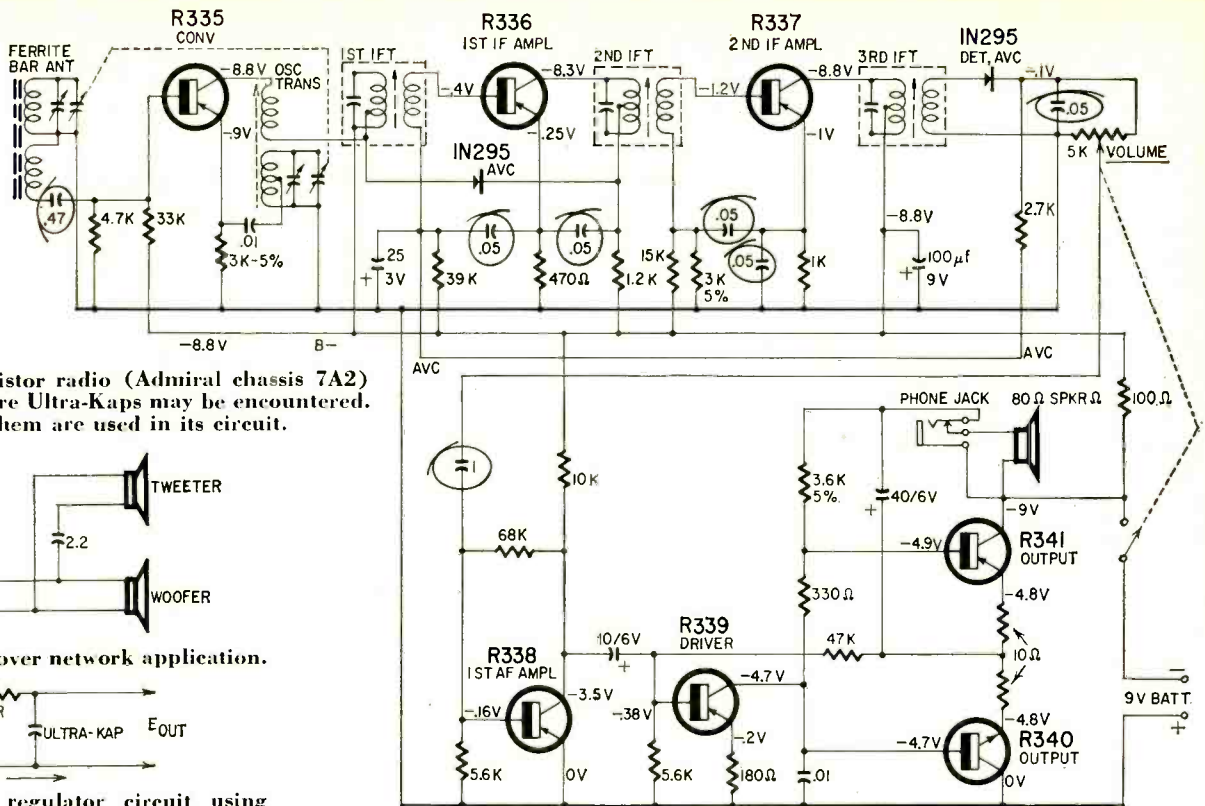

This transistor radio (Admiral chassis 7A2) shows where Ultra-Kaps may be encountered. Seven of them are used in its circuit.

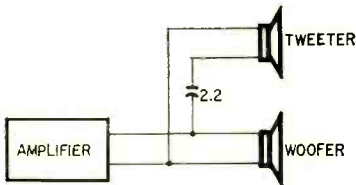

Fig. 1—A crossover network application.



Fig. 2—Basic regulator circuit using an Ultra-Kap.

capacitance of 3- and 10-volt Ultra-Kaps and will help you to identify them.

Testing

These low-voltage capacitors can be tested with an ohmmeter, by the same basic technique that is used in testing conventional capacitors except the capacitor must be checked on the lowest resistance scale of the meter. A technician usually uses the highest resistance scale or might even pay no attention to the scale being used, since most capacitors have an infinite leakage resistance. This is not true of Ultra-Kaps. As the table shows, leakage resistance is relatively low and decreases rapidly with increasing voltage.

It is apparent from the tables that the voltage applied by the ohmmeter can appreciably affect the leakage resistance reading. Most ohmmeters apply a test voltage of 1.5 or 3, so there would be no testing problems. However, some meters on the market use a higher applied voltage—they cannot be used to test these low-voltage units. If you don't know what voltage your ohmmeter applies, check the battery inside the meter before you use it.

To test a 3-volt unit, the applied voltage must be 3 volts or less. To test a 10-volt unit, the applied voltage must be 10 volts or less. Otherwise, the capacitor will appear shorted, even though it is in perfect operating condition.

While technicians generally try to replace any component with as exact an equivalent as possible, it is absolutely essential that only exact replacements be used when replacing these low-voltage high-capacitance ceramics because of the absence of series inductance in them. Equivalent paper or electrolytic capacitors have a series in-

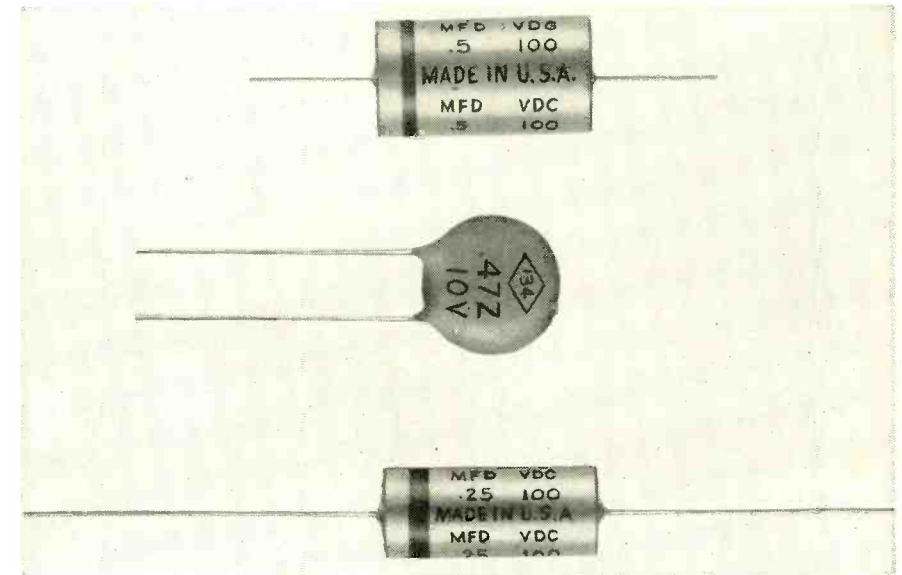

Ultra-Kap (center) compared with ordinary units of equivalent capacitance.

ductance and therefore may not operate properly in the original circuit.

A typical example of this is shown in Fig. 1. This is a simple conventional crossover network and uses a 2.2- μ f Ultra-Kap. If an electrolytic capacitor were substituted for this unit, a 10- μ f unit would be required. Depending upon the circuit function and its parameters, a paper or electrolytic replacement or even another ceramic capacitor, might require a capacitance from 2 to 10 times that of the Ultra-Kap. Since there is no simple correlation factor, it is not advisable to attempt any sort of substitution when replacing an Ultra-Kap.

While this article has dealt with the testing and replacement of Ultra-Kaps, these units have a potentially wide range of new circuit applications. Al-

though these applications have not been thoroughly investigated, it is conceivable, for example, the Ultra-Kap could be used for voltage regulation.

In Fig. 2 the Ultra-Kap in parallel with the output of the circuit would provide the basis for such a voltage-regulating device. Since the Ultra-Kap acts also as a voltage-sensitive resistor, decreasing in resistance with an increase of applied voltage, it provides voltage-equalizing characteristics at the output terminals. The Ultra-Kap could conceivably have many applications in a variety of control circuits because of this self-regulating characteristic. However, these characteristics have not been investigated to the point where their behavior in these circuits can be specifically stated. END

CITIZENS-BAND RADIO PAGES LISTENER



Distinct tone warns of message transmission so bearer can switch the unit to "receive" and get the message

By J. H. THOMAS

ARE you tired of calling yourself hoarse to get the kids home for dinner? Then equip them with a paging receiver, and call them with your 27-mc Citizens-band transmitter without ever leaving your kitchen. Although the sensitive receiver will pick up voice broadcasts from a 5-watt transmitter for many miles, it will also give a loud beep from a tone-modulated 5-watt signal for a radius of several blocks, usually enough to call the kids or communicate with someone in the vicinity. By using the 27.255-mc control frequency, you could, in fact, use 30 watts for the calling beeps to extend the paging range and then step down to 5 watts for voice communication.

Essentially, the receiver is not very different from the one shown by I. Queen in the March, 1958, issue of *RADIO-ELECTRONICS*, except that a lot of audio amplification and a special tone filter have been added to provide for the paging feature. Carried in a shirt pocket, with 2 feet of wire for an antenna, output from the single magnetic phone is loud enough to attract the wearer's attention.

Fig. 1 shows the complete schematic for the paging receiver. It consists of a superregenerative detector using an RCA 2N247 transistor and three stages of audio amplification.

Transformer coupling is used for efficiency, but resistance coupling would work too. Note how in the printed-circuit layout (Fig. 2) the transformers are mounted to avoid regenerative coupling. Similarly, it may be necessary to reverse phone connections if the magnetic type phone shows a tendency to link magnetically with the transformers. If this happens, reversing the connections provides an equivalent amount of decoupling. The single headphone used here is paralleled with a capacitor (C8) in the PAGING position of switch S1, providing a parallel-resonant circuit with the highest voltage swing for the network's resonant frequency.

The size of the capacitor must be determined for each phone and each frequency desired. But this is easy to do with an audio oscillator and a scope or ac vtvm. Simply set the oscillator for the frequency to be used, and vary the value of capacitance until maximum deflection is obtained. Or vice versa, use a capacitor you have on hand

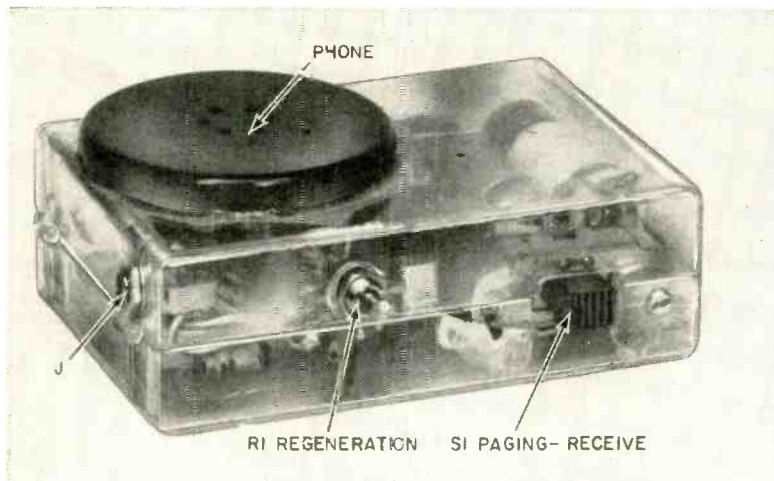

The completed receiver makes a neat shirt-pocket-size package.

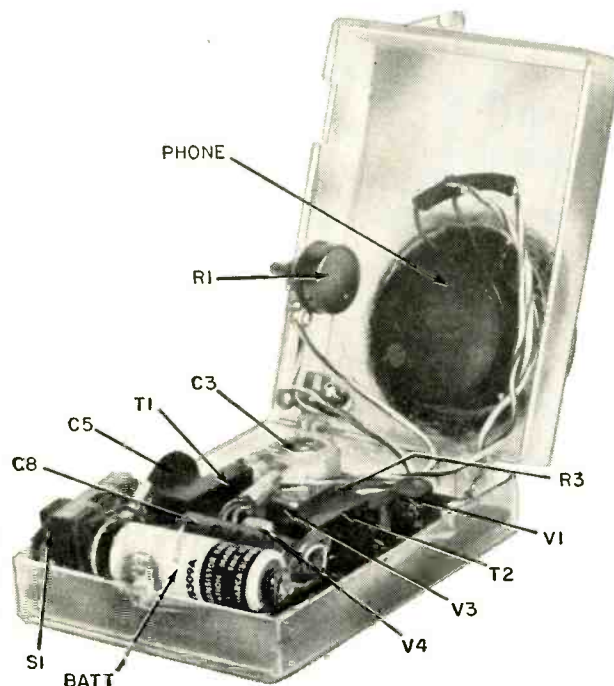

With the lid open, it is easy to see how some of the components are fastened to the case.

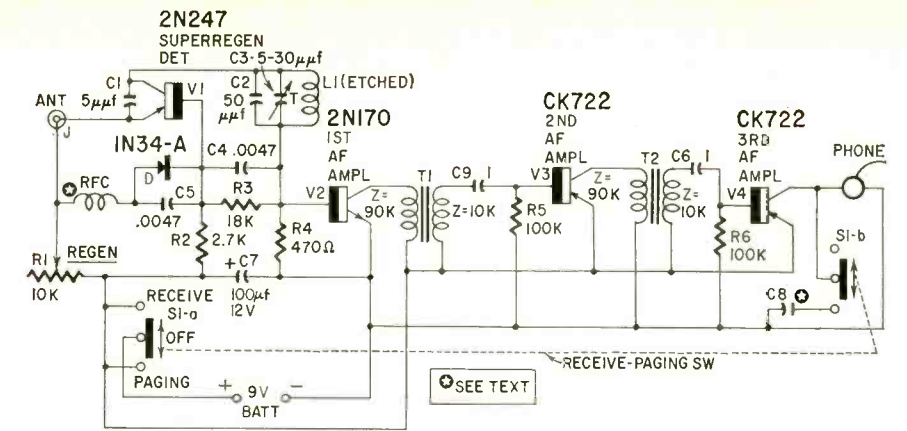

- R1—pot, 10,000 ohms, miniature
- R2—2,700 ohms
- R3—18,000 ohms
- R4—470 ohms
- R5, 6—100,000 ohms
- All resistors 1/4-watt 10% and are carried by most mail-order houses even if not listed in their catalog. For 1/4-inch length, ask for Ohmite Little Devils.
- C1—5 μ f, 15 volts, ceramic
- C2—50 μ f, 15 volts, ceramic
- C3—5-30 μ f, ceramic trimmer
- C4, 5—.0047 μ f, disc ceramic
- C6, 9—1 μ f, 15 volts, subminiature tantalum
- C7—100 μ f, 15 volts, subminiature tantalum
- C8—approximately .02 μ f, 15 volts (see text)
- BATT—9 volts (RCA VS309A or equivalent)
- D—IN34-A
- J—phone jack, miniature
- S1—2-pole 3-position slide switch
- T1, 2—miniature audio transformers: primary, 10,000 ohms; secondary 90,000 ohms (UTC 50-2 or equivalent)
- V1—2N247
- V2—2N170
- V3, 4—CK722
- Earphone, 1,000 ohms
- Etched-circuit board, single-sided, 2 1/2 x 3 1/2 inches
- Transistor sockets (4)
- Miscellaneous hardware

Fig. 1—Circuit of paging receiver calls for 4 transistors.

and vary the frequency. Use the one that gives maximum output in the circuit for calling. In the set shown, it is about 1,400 cycles, a clear penetrating tone. When the caller transmits a series of short notes, the tone becomes even more obvious. The receiver then flips switch S1 to the RECEIVE position and can listen to the transmitter.

Construction details

The entire unit is built into a 2 1/2 x 3 1/2 x 1 1/4-inch plastic box. Actual component mounting is on the etched-circuit board, which is shown full size in Fig. 2. The antenna coil is etched right into the board. The coil, with the capacitors shown, tunes from about 25 to 30 mc, much more than is required. However, this is just as well, since in copying the etched-circuit coil there might be some differences in the coil inductance. The space allowed for resistors may seem small but nevertheless is correct, for these are 1/4-watt resistors that are only 1/4 inch long and 5/64 inch in diameter. There is probably room for larger resistors, but

Fig. 2—Details of the printed-circuit board's layout.

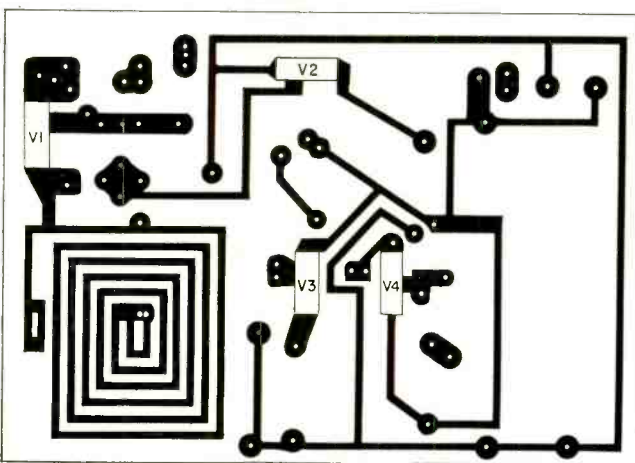

you will then have to allow for them in laying out the etched-circuit board.

The rf choke is made from a small resistor. On a standard 1/2-watt resistor, wind 36 turns of No. 34 enamel-covered wire. The resistor should have a high value. I used 10 megohms.

Operating instructions

In use, there is nothing simpler. As with all superregenerative circuits, the regeneration control (R1) must be adjusted until a hiss is heard, and then with a small alignment screwdriver the trimmer (C3) can be adjusted for the proper frequency. Since frequency is affected materially only by the tuned circuit and not by the transistor, detuning because of temperature effects is no problem. The set should be aligned with the case closed. Make a small hole in the case for this purpose.

The receiver shown in the photos is slightly different from the one suggested by the etched-circuit boards. A more advantageous arrangement of some of the parts was included in the new board. Space requirements depend

somewhat on the space needed by the phone. I used a Navy surplus single headpiece of 1,000 ohms impedance. This is about standard size. But a larger phone should be carefully fitted before holes are cut; it may require rearranging the parts. When in use, switch S1 is left in the PAGING position.

Calling the kiddies is just one of the less commercial uses of this receiver. It can also be used on a construction project where phones cannot be installed and some means must be available to call superintendents or inspectors to the phone or office. Or it can be used by firefighters who must be informed of where to go and where not to go. This receiver is a lot lighter and easier to pack than a regular walkie-talkie, and much less expensive. In disaster areas it could be worn by rescue workers, doctors or other personnel. It could be used in play rehearsals as a prompting receiver, or on movie sets (some of which are quite large) to instruct the actors (or the horses) on their next move. And there are many other uses for this 27-mc receiver which make it well worth building, particularly if you already have a 27-mc Citizens band transmitter.

Possible modifications include the use of UTC DO-TS transformers to reduce the size of the unit. No particular advantage is gained by using a 2N384, except slightly more sensitivity. Another approach would be to use R-C-coupled audio stages, but this does not save much space, since the additional resistors and capacitors will take up the room vacated by the transformers and more stages will be needed for the same result. The antenna can be a length of wire taped to a belt, and the receiver itself suspended from the belt, if shirt-pocket carrying is undesirable—but somewhat less efficiency must then be expected. Current consumption of the set when regenerating is approximately 2.5 ma from the 9-volt battery, so the unit can be used many, many hours on a single battery. The set will keep operating all the way down to 6 volts, allowing extra hours from weak batteries. Overall, the 4-transistor set is an economical little receiver that can be used in a thousand different ways.

END

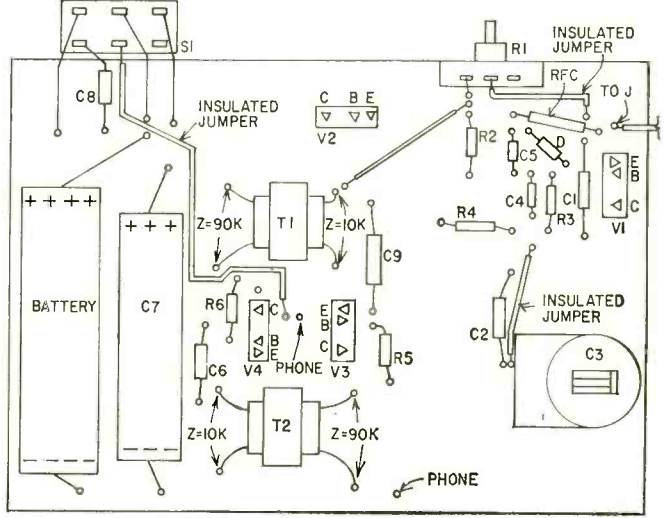

STRAIN GAUGES

what they can do

Some actual industrial applications

By **ARTHUR S. KRAMER**

THE article "A Look at the Electronic Strain Gauge" (December, 1960) told rather completely how electronic strain gauges and load cells are made and how they work. For the benefit of the newcomer, a strain gauge is usually a piece of wire made of a material that changes in resistance considerably with slight stretching. It is cemented to a piece of paper or fabric which is in turn cemented to the object in which strains are to be measured. When the object is subjected to strain, its shape is distorted and the fine wire of the strain gauge stretched or compressed. The changes in resistance are usually sensed electrically by making the gauge one arm of a bridge and are amplified to give an indication on a meter or a trace on a recorder.

How strain gauges are used is the subject of this article. Only a few of the more interesting and important applications are pictured and described.

A setup for testing flanged hub bolts on a wind-tunnel fan is shown in Fig. 1. Baldwin SR-4 gauges are used.

Baldwin SR-4 load cells can be used to measure horizontal thrust of jet engines, as well as for weighing.

Fig. 2 is a head-on view of a large jet engine on the thrust stand in Ryan Aeronautical Co.'s test cell in San Diego. The load cells are located under the engine platform.

B-52G aircraft static testing is shown in Fig. 3. The forward end of the craft faces the camera and some 10 or 15 strain gauges are attached to the top surface of the fuselage. Leads from each of the gauges go to a frame above the fuselage and then down to indicating and recording equip-

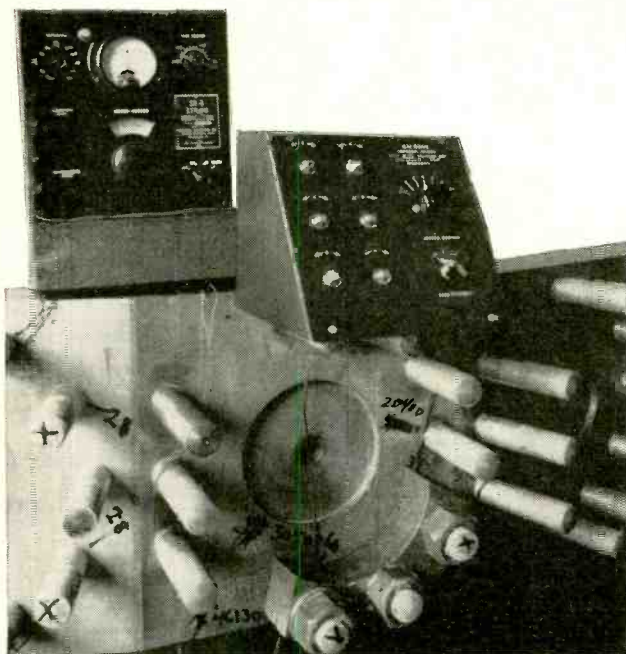

Figure 1

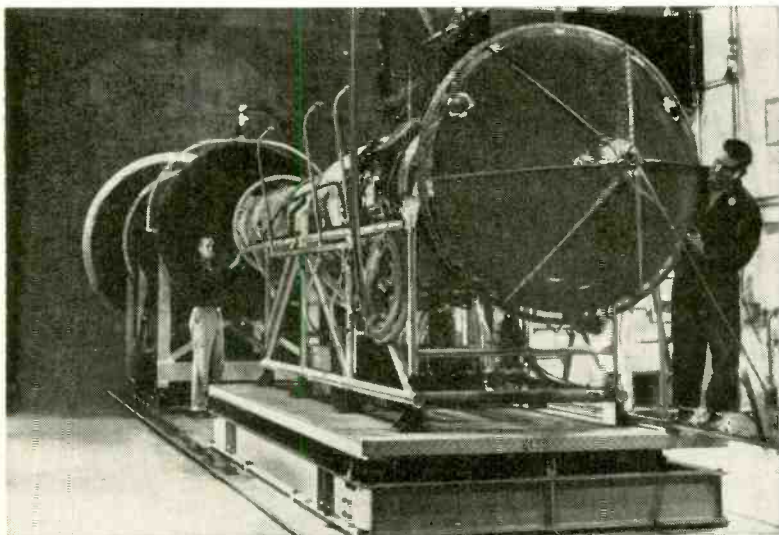

Figure 2

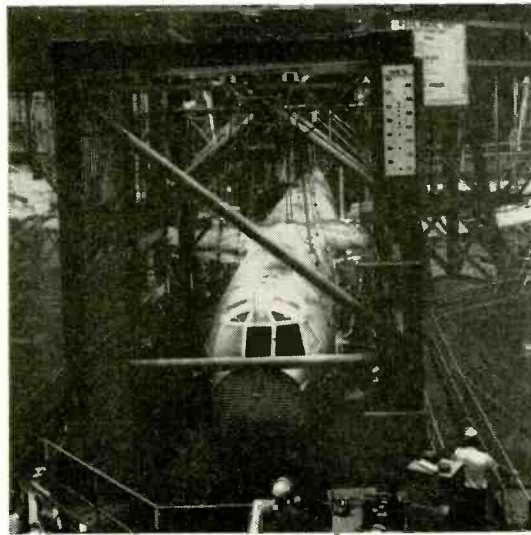

Figure 3

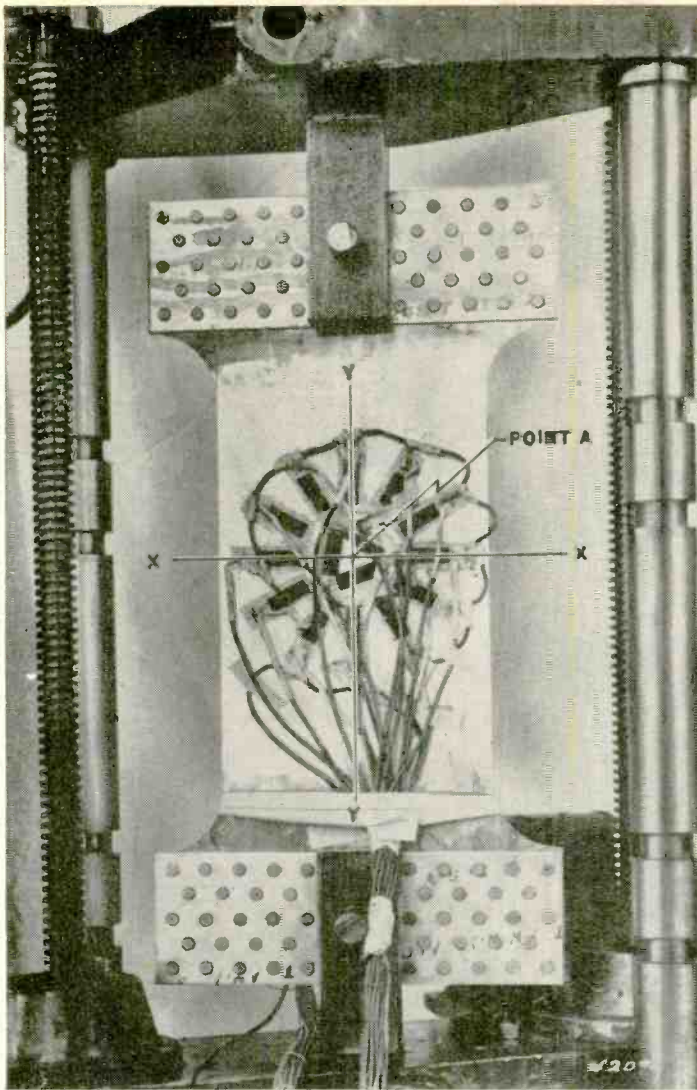

Figure 4

ment that appears in the foreground.

Fig. 4 shows a setup for making a stress analysis of a special steel panel at Ford Motor Co. Some 15 gauges are arranged in a circle to measure strain in many directions. The panel is fastened to the base and the movable platform of the stress machine as shown. Stress can be applied to the panel by turning the jack screws. Wire leads come down to remote indicating equipment (not shown).

Strain gauges can also be used for vibration testing. Such an application is shown in Fig. 5, where Baldwin-Lima-Hamilton SR-4 gauges are being cemented to the blade of a Curtiss-Wright propeller.

An interesting application of strain gauges is found in observing and measuring strains in a shotgun barrel. As shown in Figs. 6 and 7, three gauges were placed at three points along the barrel. The oscillograms show that the greatest strain occurs at the breech, and that the strain drops progressively toward the muzzle.

In Fig. 8 we see one of four load cells used to weigh hot metal at Armco Steel Corp. in Houston, Tex. The load cell is the cylindrically shaped device with the electrical conduit projecting from its side.

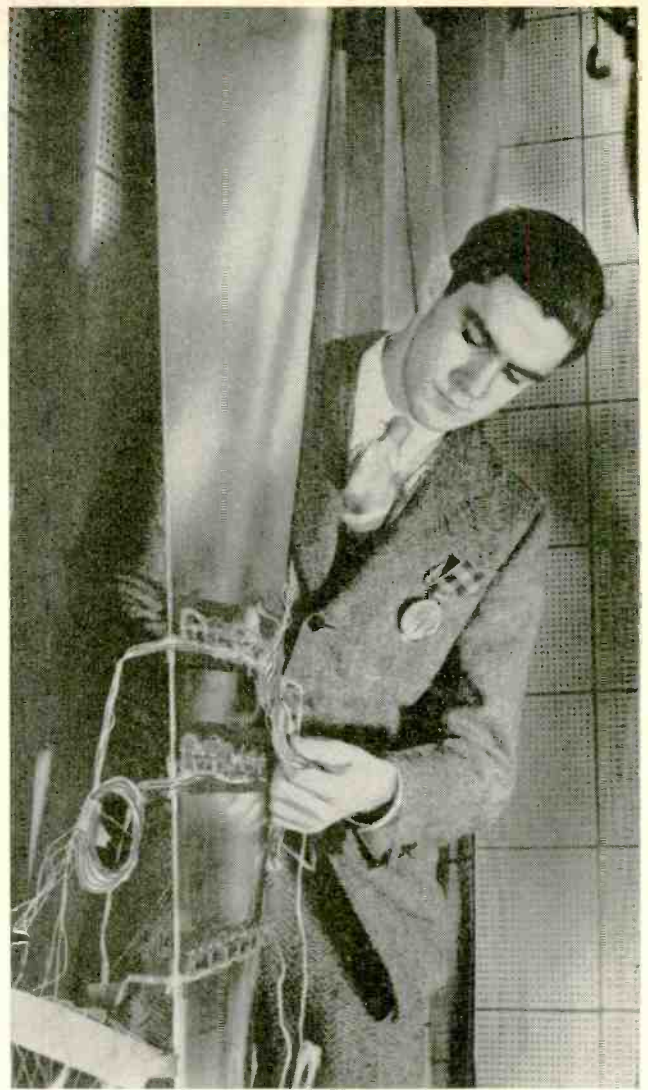

Figure 5



Figure 6

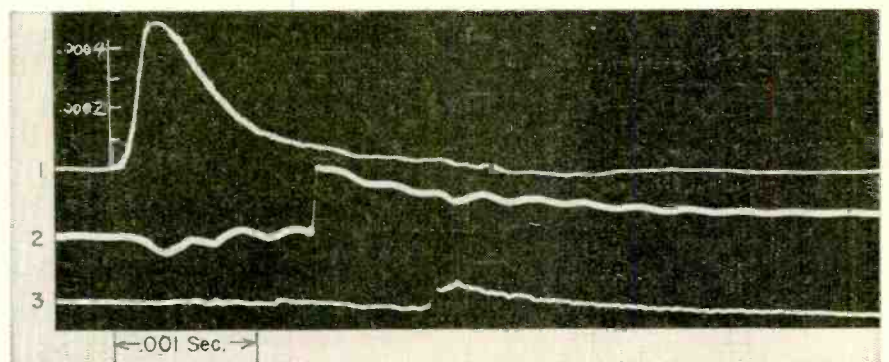

Figure 7

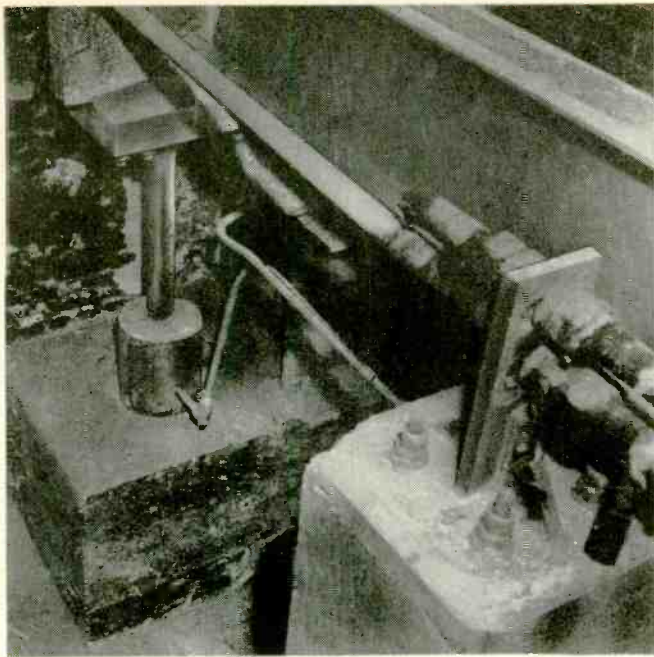

Figure 8

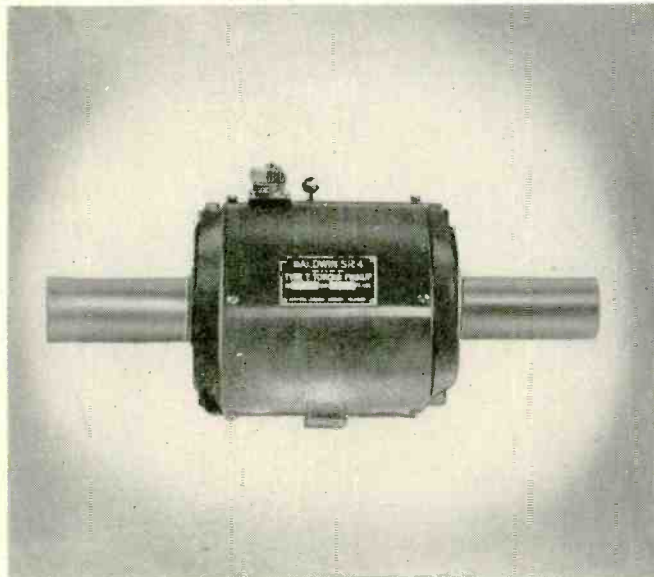

Figure 9-a

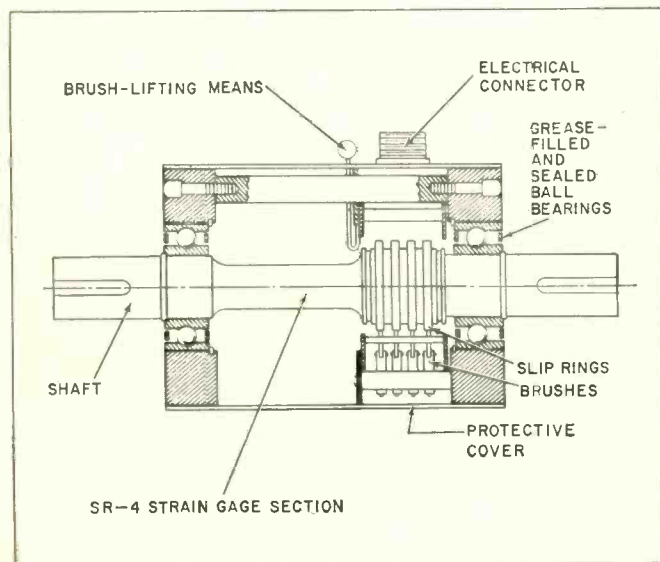

Figure 9-b

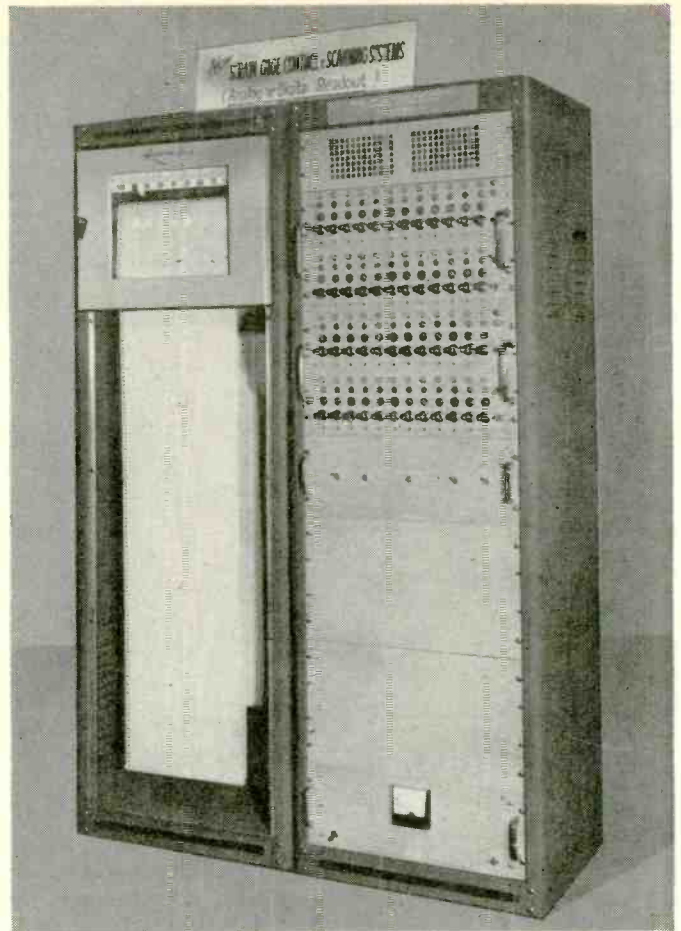

Figure 10

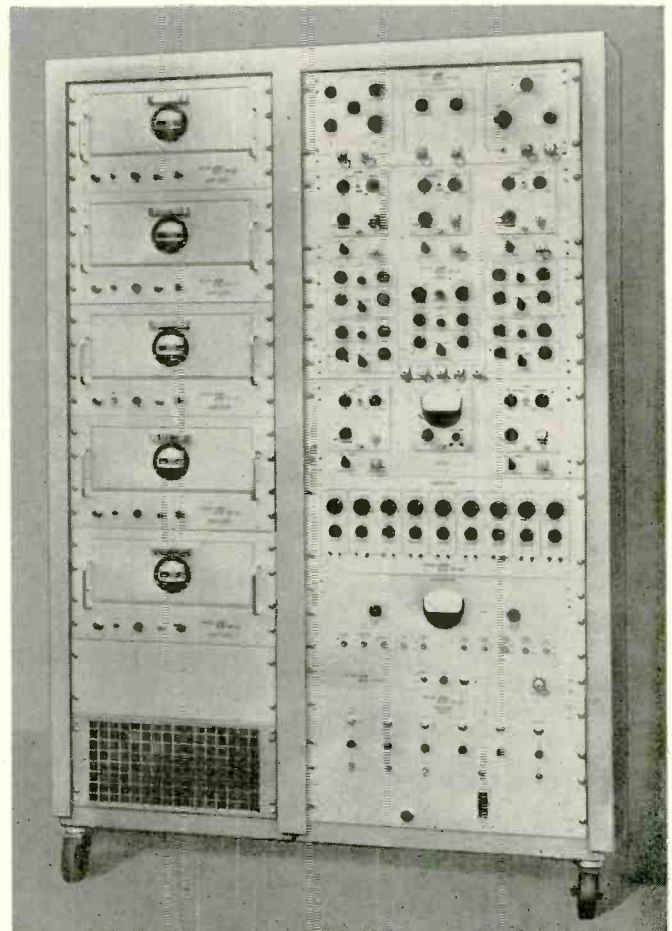

Figure 11

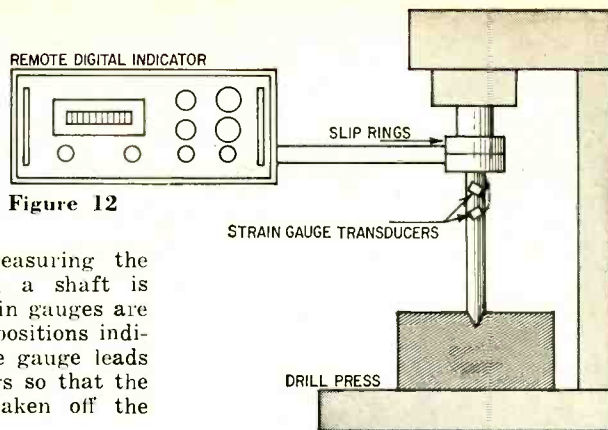

Figure 12

A device used for measuring the torque required to turn a shaft is shown in Fig. 9. The strain gauges are cemented to the shaft in positions indicated in Fig. 9-b and the gauge leads connected to the slip rings so that the output signals can be taken off the brushes.

In Fig. 10 we see a "multichannel data logger" designed and built by B. & F. Instruments, Inc., of Philadelphia. This device provides strain-gauge input conditioning for aircraft and missile flight testing. In such applications, scores of strain gauges are used, and each acts as a separate channel of information which must be recorded. This data logger provides 48 separate channels and plots strain vs load. Connections from the gauges are made via gold-plated AN connectors to maintain low contact resistance. Each remote gauge is connected to its own bridge circuit, and each bridge output is connected, in turn, to the recorder-plotter by the internal scanning switches.

In Fig. 11 we see the Electronic Tube Corp. (Philadelphia) model K-55 automatic five-channel recording system. Its purpose is to provide an automatically programmed system to record on film the output of several strain gauges used for static testing of rocket propellants, heavy artillery and dynamic stress-strain measurements. The indicator unit contains a five-gun cathode-ray tube, type 55PAP11, which is mounted through the side of the instrument. The unit operates very nearly the same as five conventional oscilloscopes but with the information displayed on only one cathode-ray tube. The unit can be used to control a complete program, including such actions as starting the cameras, recording the phenomena, calibrating, firing the unit under test and shutting the system down.

The Baldwin type N strain indicator is a small, transistorized, portable instrument that can be set up at any remote point to read strains directly in values of micro-inches per inch. The dial readability is 2 μ in per inch and its accuracy is $\pm 3 \mu$ in per inch.

Performance Measurements Co. of Detroit manufactures a universal strain-gauge transducer indicator which produces a direct digital readout from any transducer using bonded or unbonded strain gauges. Fig. 12 shows how torque produced in rotating equipment such as a drill press may be measured with a pair of strain gauges bonded directly to the drill and read on the digital indicator directly.

Typical circuits

The simplest strain-gauge circuit is that in Fig. 13, in which a strain gauge

(R_g) is connected in series with a battery and a fixed or "ballast" resistor R . The circuit is capacitively coupled to the electronic amplifier, the capacitor presenting infinite impedance to steady dc voltage but transmitting pulsating dc. It is coupled with an amplifier, and the output of the amplifier drives an oscilloscope, oscillograph, ac voltmeter or similar instrument.

To measure static strains or the static component of a varying strain, the most convenient circuit is the Wheatstone bridge. This is shown in its simplest form in Fig. 14. When this bridge is set up so that the only source of unbalance is change of resistance in the gauge, resulting from the application of strain to the gauge, the difference in potential across the output ter-

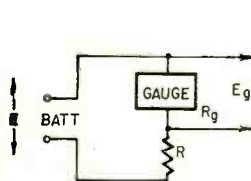

Figure 13

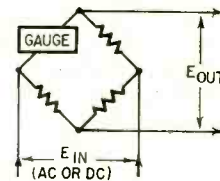

Figure 14

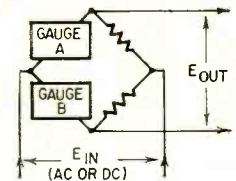

Figure 15

minals becomes a measure of that strain. This potential can be measured by a sensitive voltmeter, but for most purposes a strain indicator or recorder calibrated in terms of micro-inches per inch is much more satisfactory.

This simple form of Wheatstone bridge circuit has one serious defect. The filament wire used for SR-4 gauges is temperature-sensitive as well as strain-sensitive. The voltage measurements made from this circuit, therefore, are the combined result of strain and temperature.

To cancel any effect of temperature on the gauge wire, a circuit like that shown in Fig. 15 is used. Probably the most commonly used circuit in strain-gauge work, this circuit employs two SR-4 gauges as adjacent arms of the bridge. One of these, the "active" gauge, is mounted on the stressed metal; the other, the "dummy," is mounted on an unstressed piece of the same material. The two are located close together, so that both are subjected to substantially the same temperature.

Now, if the two gauges are identical, resistance changes due to temperature alone will be the same for both of the

Wheatstone bridge arms in which these gauges are located. The effects of temperature on the gauges will have practically no influence on the measurement of the stress-induced strain at the active gauge.

The measurement will, however, include strain due to thermally induced stresses in the metal. It is thus a true measure of stress, whether the stress results from temperature or applied force or load, or both. The dummy gauge simply compensates for the undesired temperature effects.

Latest developments

As previously mentioned, gauge factors of most commonly used metal-wire strain gauges range between values of 2 and 4. Recent experimental work indicates that germanium, silicon and other semiconductors when used as strain gauges have factors ranging from 150 to 175. This makes any circuit employing them extremely sensitive. The sensitivity is high enough that hydrostatic forces can be measured merely by immersing the gauge in the fluid. Also, static and low-frequency stresses can be measured at frequencies up to resonance of the material. Applied stress forces can be large, since semiconductors are strong structurally. These gauges are stable under conditions of high temperatures and high humidity. They respond well to torsional and shearing forces. Semiconductors

have nearly all the qualities needed for an ideal gauge.

Future outlook

It is very doubtful that our missile and space exploration effort would have made such tremendous progress without the various types of electronic strain gauges to telemeter back the happenings during flight tests. Smaller and more sensitive gauges will become available soon. Perhaps other materials will be found with gauge factors higher than those of semiconductors. It is possible that all industrial weighing will soon be done electronically, using load cells or their equivalent. Strain gauges will be useful in the field of deep-sea exploration, where pressures of thousands of pounds per square inch can set up severe strains in the submarine vessel.

Acknowledgment

The writer again acknowledges with gratitude the assistance of Mr. T. L. Gaffney of Baldwin-Lima-Hamilton Corp., Waltham, Mass., who contributed much helpful technical information and most of the photos used. END

THERE'S A NEW HEATH KIT FOR EVERYONE IN THE FAMILY!

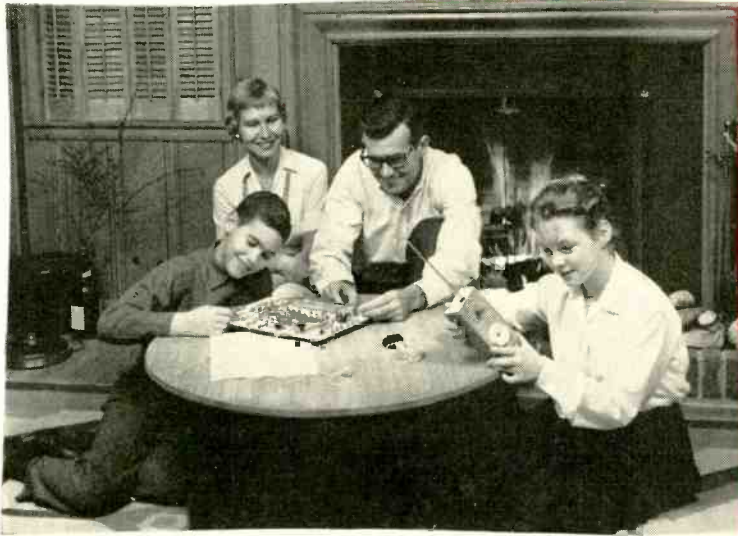

fits both space and dollar budgets!

COMPLETE STEREO-PHONO CONSOLE WIRED OR KIT

Less than 3' long and end-table height, yet its six speakers assure rich, room-filling stereo! Smooth "lows" are delivered by two 12" woofers, "mid-range" and "high" are sparkingly reproduced by two 8" speakers and two 5" cone-type tweeters mounted at wide dispersal angles in the cabinet. The "anti-skate" 4-speed automatic stereo/mono record changer has diamond and sapphire styli. Concentric volume and separate dual bass and treble tone controls are within easy reach. Superbly styled with solid genuine walnut frame, walnut veneer front panel, and matching "wood-grained" sliding top, the cabinet measures just 31 $\frac{3}{4}$ " L x 17 $\frac{5}{8}$ " W x 26 $\frac{3}{4}$ " H. Whether you buy the ready-to-play or kit form, the cabinet is factory assembled and finished; to build the kit, just wire the amplifier and install the changer and speakers. 70 lbs.

Model GD-31 (kit) ... \$13 dn., \$11 mo. **\$129.95**
 Model GDW-31 (wired) ... \$15 dn., \$13 mo. **\$149.95**



INTRODUCING

... a superb new line of Stereo Hi-Fi Consoles ...
FACTORY ASSEMBLED, ready to play!

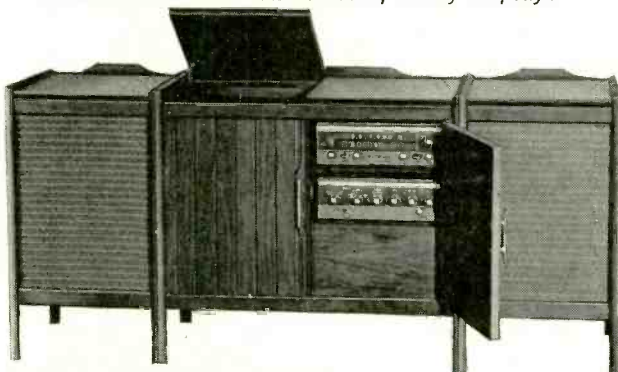

COMPLETE 28-WATT AND 50-WATT STEREO CONSOLES

Now you can buy Heath stereo components factory-wired and tested with beautiful preassembled, prefinished cabinets ... ready to plug in and enjoy. The consoles are available in both 28 and 50 watt models, with money-saving optional kit plans. The 28-watt model (HFS-26) contains the Heathkit AJ-10 stereo AM/FM tuner, SA-2 stereo amplifier, AD-50A stereo record changer and two US-3 12" coaxial hi-fi speakers. The 50-watt model (HFS-28) contains the Heathkit AJ-30 Deluxe stereo AM/FM tuner; AA-100 Deluxe stereo amplifier; AD-60B Deluxe stereo record changer and two Jensen H-223F coaxial 2-way 12" hi-fi speakers. Specify walnut or mahogany.

Model HFS-26 (wired) ... 215 lbs. \$47.50 dn. **\$475.00**
 Model HFS-27 (kit) ... \$37.00 dn. **\$370.00**
 Model HFS-28 (wired) ... 264 lbs. \$75.00 dn. **\$675.00**
 Model HFS-29 (kit) ... \$55.00 dn. **\$550.00**
 Cabinets available separately, write for information.



HEATH COMPANY / Benton Harbor, Michigan

NOW ONLY
HEATH
BRINGS YOU
ALL 3!



1.
HEATHKIT
for
do-it-yourself
hobbyists.
2.
HEATHKIT
factory-built,
ready to use.
3.
HEATHKIT
learn-by-doing
Science Series
for youngsters.



**PORTABLE 4-TRACK STEREO
TAPE RECORDER KIT**

Delight to the vast treasures available to you in popular 4-track pre-recorded stereo tapes . . . make your own 4-track stereo home recordings . . . (you can even use it as a hi-fi center to amplify and control hi-fi tuners, record players, etc.) Has "record," "play," "fast-forward" and "rewind" functions, 2 speeds (3 $\frac{3}{4}$ " and 7 $\frac{1}{2}$ " per second). Controls include: individual tone balance controls for each channel; level controls; monitoring switch for each channel to let you hear programs as they are being recorded; and a pause button for tape editing. Two "eye-tube" indicators provide control of recording levels. Speaker wings may be detached. Cabinet and tape mechanism are completely preassembled. A storage compartment is provided for tape and accessories. 49 lbs.

Model AD-40 . . . \$18 dn., \$16 mo. **\$179.95**

**STEREO/MONO
PORTABLE PHONO KIT**

From jazz to classics, the younger set will have stereo wherever they go! Plays either stereo or mono records on its top quality 4-speed automatic changer with diamond and sapphire styli. Has detachable stereo speaker wing and complete tone and stereo balance controls. Record changer and cabinet are factory-assembled, the kit is a "snap" to build. 15 $\frac{1}{2}$ " x 18" x 8 $\frac{3}{8}$ ". 28 lbs.

Model GD-10 . . . \$7 dn. **\$69.95**

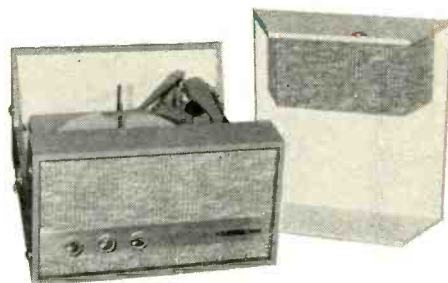

ACOUSTIC SUSPENSION SPEAKER SYSTEM KIT

Using the revolutionary "acoustic suspension principle" licensed to Heath by Acoustic Research, Incorporated, the AS-10 meets and surpasses performance of speaker systems three to four times its size. The 10" bass speaker and two 3 $\frac{1}{2}$ " hi-frequency speakers cover 30 to 15,000 cps with fantastic brilliance and fidelity! Use in upright or horizontal position. Cabinets pre-assembled and prefinished. 32 lbs.

Model AS-10U (unfinished) . . . \$6 dn., \$6 mo. **\$59.95**

Model AS-10M (mahogany) . . . \$6.50 dn., \$6 mo. **\$64.95**

Model AS-10W (walnut) . . . \$6.50 dn., \$6 mo. **\$64.95**



DELUXE AM/FM STEREO TUNER

Exciting new styling and advance-design features rocket this new Heathkit to the top of the stereo hi-fi value list! Featured are: complete AM, FM and simultaneous stereo AM/FM reception, plus a multiplex adapter output; individual flywheel tuning; individual tuning meters on each band; FM automatic frequency control (AFC); and AM bandwidth switch. 24 lbs.

Model AJ-30 (kit) . . . \$9.75 dn., \$9 mo. **\$97.50**

Model AJW-30 (wired) . . . \$15.30 dn., \$13 mo. **\$152.95**



DELUXE 50-WATT STEREO AMPLIFIER

Look-alike companion to the tuner above, here's two 25-watt channels hi-fi-rated and loaded with extras! Mixed-channel center speaker output; "function selector" for any mode of operation; stereo reverse, balance and separation controls; ganged volume and separate concentric bass and treble tone controls. 5 $\frac{1}{2}$ " H, 15 $\frac{3}{4}$ " W, 13 $\frac{1}{2}$ " D. 31 lbs.

Model AA-100 (kit) . . . \$8.50 dn., \$8.00 mo. **\$84.95**

Model AAW-100 (wired) . . . \$14.50 dn., \$13.00 mo. **\$144.95**



8 new, exciting Heathkit® products on following pages

HEATHKIT®... pioneer in do-it-yourself

NOW... BUY YOUR HEATHKIT FOR as low as \$2.50 DOWN! Yes, under the new, easy Heath Time Payment Plan, orders of \$25.00 or more can be purchased for just 10% down... and up to 18-FULL MONTHS ON BALANCE for orders of \$300 to \$600.

So, don't wait... enjoy that Heathkit you've wanted so long NOW... for just a small amount down, and pay the balance in easy monthly installments!



ANNOUNCING THE ALL-NEW HEATHKIT "WARRIOR" GROUNDED-GRID KILOWATT LINEAR ONLY \$229.95

Here's news to rock the entire Amateur Radio world! The new desk-top Heathkit "Warrior" matches any unit on the market feature for feature with no quality short cuts and slashes the price in half! *Completely Self-Contained*—amplifier and HV, filament, and bias supplies are built in. *Versatile*—drives with 50 to 75 watts, no matching or swamping network required. *Efficient*—stable g-g circuit puts part of drive in output for up to 70% efficiency. *Inexpensive Tubes*—four paralleled 811A's and two 866A's. *Dynamic Regulation*—big oil-filled capacitor and 5-50 henry swinging choke for high peak power output with low distortion. *Design*—special low-capacity filament transformer requires less driving power and eliminates broad-band filament RF choke. *Monitoring*—gives constant output to scope regardless of frequency. *Easily Assembled*—average time 8 hours. *Bands*—80 through 10. *Max. Power Input*—SSB-1000 watts PEP; CW-1000 watts; AM-400 watts (500 using controlled carrier mod.); RTTY-650 watts. *Write for Complete Information.*

Model HA-10... 100 lbs.... \$23.00 dn., \$20.00 mo..... **\$229.95**



DELUXE SERVICE BENCH VTVM KIT

Greater accuracy and convenience for precision testing. Big 6", 200 ua meter has longer scales plus separate 1.5v and 5v AC scales. Wider frequency coverage with greater precision is made possible through use of 1% resistors and husky capacitors. Other deluxe features include high-visibility meter and controls; recessed thumb-wheel "zero" and "ohms adjust" controls. Measures AC and DC volts to 1500 in 7 ranges; resistance from .1 ohm to 1,000 megohms in 7 ranges. Db calibrations for relative voltage measurements selected to give 10 db steps between ranges. Test leads included. 9½" H x 6½" W x 5" D. 7 lbs.

Model IM-10... \$3.30 dn., \$5.00 mo..... **\$32.95**



NEW ISOLATION TRANSFORMER KIT

The IP-10 presents a significant improvement in isolation transformers. Provides output voltage from 90-130v in 0.75v steps at 300 watts continuous duty, 500 watts intermittent duty, with 117v input—ample power for even color TV servicing. Built-in meter continuously monitors output voltage with ± 1 volt accuracy (linear scale is electronically expanded to cover 90-140v). Power line input voltage can also be measured by operating spring-return slide switch on front panel. Fused primary. Measures 6½" W x 9½" H x 5" D. 22 lbs.

Model IP-10... \$5.50 dn., \$5 mo..... **\$54.95**



NEW FOR THE SIX & TWO METER VHF NOMADS...

The new "Shawnee" 6-meter and "Pawnee" 2-meter Heathkit transceiver kits bring a new definition to superior performance. And each offers complete AM and CW facilities with the greatest array of features anywhere! *Single Knob Tuning*—tracked VFO and exciter stages. *10 Watt Output*—6360 dual tetrode. *Built-In Low Pass Filter*. *Three-way Power Supply*—built-in for 117vac, 6vdc or 12vdc with separate DC and AC plugs and cables included. *Dual-Purpose Modulator*—10 watts for high level plate modulation or 15 watts for PA operation. *Double Conversion Receiver*—crystal controlled first oscillator. *Voltage Regulation*—on all oscillators. *Complete Controls*—up front on the panel for transmitter and receiver. *Tuning Meter*—auto-switched for signal strength or relative power output. *Slide Rule Dial*—seven inches of spread for receiver and VFO, edge lighted. *VFO or Crystals*—front panel switch of vfo or four crystals for novice, CAP, MARS or net operation. *Spot Switch*—zero in signals with transmitter off. *Complete Shielding*—power supply, final and receiver front end. *Ceramic Microphone*—push-to-talk with coiled cord. *And many more*—Write for Information. 34 lbs.

Model HW-10... 6 meter, or HW-20... 2 meter \$20 dn., \$17 mo..... **\$199.95**

HEATH COMPANY / Benton Harbor, Michigan

electronics—always the leader!

now a new improved
6 meter model
joins this famous
transceiver series



ATTENTION MARINERS!
Keep a "weather-eye" peeled for
announcement of a new Heathkit
SHIP-TO-SHORE RADIOTELE-
PHONE . . . COMING SOON!

2, 6 & 10 METER TRANSCEIVER KITS

The new 6 meter HW-29A joins "Tener" and "Twoer" to bring you top transceiver values. Like "Twoer," the new HW-29A multiplies to its output frequency from an 8 mc crystal for greater stability. All models have crystal-controlled, 5 watt input transmitters and tunable super-regen receivers that pull in sigs as low as 1 uv . . . FB for emergency work and "local" nets. Each includes transmit-receive switch, metering jack, ceramic mike and two power cables. Less crystal. 10 lbs.

- Model HW-19 . . . 10 meter . . . \$4 dn., \$5 mo. **\$39.95**
- Model HW-29A . . . 6 meter . . . \$4.50 dn., \$5 mo. **\$44.95**
- Model HW-30 . . . 2 meter . . . \$4.50 dn., \$5 mo. **\$44.95**
- Model HWM-29-1 . . . Converts early "Sixer" to "A" model.
1 lb. **\$4.95**



be your own
"tune-up" specialist!

NEW ELECTRONIC IGNITION ANALYZER KIT

Checks ignition faults quickly and accurately. One simple hook-up to ignition wiring, and the IO-20 does the rest! No removing plugs, wiring or other engine parts. Checks engine in operation. Switch selection of primary, secondary, parade or superimposed patterns without changing leads to the engine. Detects shorted plugs, defective distributor points, defective wiring, coil and condenser problems, incorrect dwell time, worn distributor parts, etc. Features improved trigger circuit for locked-in patterns without trigger level adjustment; 2-1 vertical and 10-1 horizontal expansion. 8" H x 9½" W x 16" D. 22 lbs.

Model IO-20 . . . \$8.95 dn., \$9.00 mo. **\$89.95**

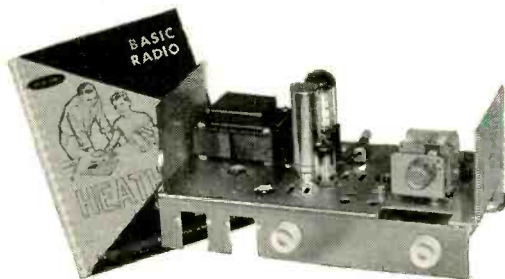

HEATHKIT BASIC RADIO COURSE

Here's a new 2-part series in basic radio for youngsters and adults. "Basic Radio—Part I," available now, teaches radio theory in everyday language, common analogies, and no difficult mathematics. Experiments performed with radio parts supplied result in a regenerative radio receiver. "Part II" of the series, which will be ready March 1, advances your knowledge of radio theory and supplies additional parts to extend your Part I receiver to a 2-band superheterodyne circuit.

Model EK-2A . . . "Part I" . . . 8 lbs. **\$19.95**

MONEY BACK GUARANTEE

Heath Company unconditionally guarantees that each Heathkit product, whether assembled by our factory or assembled by the purchaser in accordance with our easy-to-understand instruction manual, must meet our published specifications for performance or your purchase price will be cheerfully refunded.

FREE CATALOG



Send today for your Free Copy of the latest Heathkit Catalog showing over 200 Heathkit items for hi-fi fans, amateur radio operators, students, technicians, marine enthusiasts, sports car owners and hobbyists. Many Heathkit products are now available in both kit and wired form!

ORDER DIRECT BY MAIL OR SEE YOUR HEATHKIT DEALER



HEATH COMPANY
Benton Harbor 20, Michigan

ORDERING INSTRUCTIONS

Fill out the order blank below. Include charges for parcel post according to weights shown. Express orders shipped delivery charges collect. All prices F.O.B. Benton Harbor, Mich. A 20% deposit is required on all C.O.D. orders. Prices subject to change without notice.

Please send the following HEATHKITS:

ITEM	MODEL NO.	PRICE

Ship via () Parcel Post () Express () COD () Best Way

() SEND MY FREE COPY OF YOUR COMPLETE CATALOG

Name _____

Address _____

City _____ Zone _____ State _____

Dealer and export prices slightly higher.

INTERCOM...

Single amplifier does the job of six interconnected master-station intercoms

Super-duper model 1

By PETER J. VOGELGESANG*

AN intercom system is usually made up of one master station and a group of remote speakers. The master can call any or all of the remotes and each remote can call the master, but communication from one remote to another is impossible. For a completely versatile system, you would need a master unit at every station, but then every station requires ac power and many amplifiers must operate simultaneously. Then, too, multi-conductor cable connection between all master stations is required.

You can keep almost all the advantages of an all-master system and still have only one amplifier by using a comparatively simple relay exchange to route the amplifier's output to any preselected remote.

The unit's amplifier is conventional. Its input is matched to the remote speakers with a voice-coil-to-grid transformer. The amplifier's output is fed to the relay exchange.

Exchange circuits

As in the schematic, the audio output is routed through the normally closed contacts of all six exchange relays, where it is returned to ground through the normally closed contact of the last relay, muting the amplifier. If any of the relays is energized, the grounding circuit is opened and the amplifier's output is fed through the normally open contact of that relay to the respective remote station. By energizing the proper relays, the amplifier can be made to feed any one of the remote stations.

Each relay is energized by the plate current of a triode which is normally cut off because of a negative bias on the tube's grid. Bias voltage is obtained from the 117-volt winding of T4. The 90-volt rectified output is dropped through a series of resistors to produce voltages in increasing increments of -15 volts. Each discrete voltage is fed through a 4.7-megohm resistor to the grid of one of the triodes. When the negative supply is returned to ground by R26, all the triodes are cut off. However, by returning it to some positive voltage, the bias on any or all of the triodes can be effectively removed, thereby causing them to conduct. For example, if the junction of R24 and R26 is returned to positive 60 volts, the

triodes that operate relays RY3 through RY6 have no bias and will close the relays. The triode operating relay RY2 still has a grid bias of -15 volts and the triode connected to relay RY1 has a bias of -30 volts so these two relays will not be actuated. At V6, there is a positive voltage on the grids, but 4.7-megohm grid resistors limit grid current and protect the tubes.

Although RY3 through RY6 are all actuated, only RY3 routes the amplifier output to a remote speaker because, when it closes, it opens the contacts that feed audio to RY4, RY5 and RY6. In this way, any of the six exchange relays can be closed by returning the negative supply to the correct positive voltage. Control of the exchange relays is simply a matter of providing a system that lets each remote station supply a variable reference voltage to the negative supply.

A conventional intercom usually requires a three-conductor cable between the master station and each remote station. One wire is a talk line, one is a listen line and the third is common to both and is usually at ground potential. By using a five-conductor cable between the amplifier and each remote station, a positive voltage equal to the full voltage of the negative supply can be carried to each remote station on the fourth line, and a referencing voltage can be carried back to the exchange system on the fifth line. Thus it is possible to control the exchange from each remote station. How this is done is shown in the diagram of a remote station.

The remote units

About 100 volts is tapped from the amplifier's power supply and is fed to each remote station. Normally it is not used. However, when the FUNCTION switch of any remote station is depressed, the voltage is fed to potentiometer R29. The wiper of the potentiometer taps part of this voltage and sends it through the FUNCTION switch to the exchange circuits over the control line. By rotating the potentiometer, it is possible to control every relay in the exchange. If linear potentiometers are used, as recommended, they can be calibrated in six equal divisions, each one representing one of the remotes.

In operation, with none of the FUNC-

TION switches depressed, all remote speakers are connected to the listen line and the negative supply in the exchange is referenced to ground by R26. When a call is originated at any remote station, the potentiometer at that station is set to the station being called. Now, when the FUNCTION switch at the transmitting station is depressed, it not only switches that speaker to the talk line—it also sends a referencing voltage to the exchange that will route the audio output to the station being called. Before answering, the potentiometer at the station being called must be set to the station originating the call. As the two stations converse alternately, the

- R1—1,800 ohms
- R2—1 megohm
- R3—470,000 ohms
- R4—pot, 1 megohm, audio taper, with spst switch
- R5—10,000 ohms
- R6—270 ohms, 1 watt
- R7, 8, 9, 10, 11, 12—27,000 ohms, 1 watt
- R13, 14, 15, 16, 17, 18—4.7 megohms
- R19, 20, 21, 22, 23, 24—2,700 ohms, 1 watt
- R25—220 ohms
- R26—2.2 megohms
- R27—18,000 ohms, 2 watts
- R28—10,000 ohms, 2 watts
- R29—pot, 100,000 ohms, linear taper
(1 per remote station)
- All resistors 1/2-watt 10% unless noted
- C1—250 μ f, ceramic
- C2—10 μ f, 25 volts, electrolytic
- C3—.02 μ f, paper
- C4—.01 μ f, paper
- C5—10 μ f, 450 volts, electrolytic
- C6—25 μ f, 25 volts, electrolytic
- C7—20-20 μ f, 450 volts, electrolytic
- C8—40 μ f, 200 volts, electrolytic
- C9—0.1 μ f, 200 volts, paper
- Capacitors 600 volts unless noted
- CH—Filter choke, 8 henrys, 100 ma, 375 ohms
(Merit C-2995 or equivalent)
- F—2 amps
- RECT—75 ma, 130 volts, selenium
- RY1, 2, 3, 4, 5, 6—relay, sealed miniature, spdt contacts, 10,000-ohm coil (Potter Brumfield SM5LS or equivalent)
- S1—spst on R4
- S2—4 poles, 2 positions, lever action, spring return (Mallory 7242L or equivalent)
(1 per remote station)
- T1—intercom transformer: primary, 4 ohms; secondary, 25,000 ohms (Stancor A-4744 or equivalent)
- T2—universal output transformer; use 5,000-ohm primary; 4-ohm secondary (Merit A-2900 or equivalent)
- T3—power transformer: primary, 117 volts; secondary, 560 volts ct, 90 ma; 6.3 volts, 5 amps; 5 volts, 2 amps (Merit P-3052 or equivalent)
- T3—filament transformer: primary 117 volts; secondary, 6.3 volts, 1 amp (Merit P-2944 or equivalent)
- T4—filament transformer: primary, 117 volts; secondary, 6.3 volts, 1 amp. (Merit P-2944 or equivalent)
- T5—terminal strip, 10 lugs, barrier type
- V1—6AU6
- V2—6AQ5
- V3—5Y3-GT
- V4, 5, 6—12AT7
- Chassis, 5 x 10 x 3 inches
- Miscellaneous hardware

*Engineer, KSTP-TV.

relay exchange will route the amplifier output alternately as the respective FUNCTION switches are depressed.

The system has limitations. Only one conversation can be held at a time, and only one station can be called at a time. A call to two stations simultaneously is impossible. In spite of these limitations, the overall system is nearly as versatile as an all-master conventional system but is simpler, more economical to build and operate, and easier to install.

The amplifier can be located at some point near the center of the system to eliminate long runs of interconnecting lines. It can be placed in a closet or any other out-of-the-way place because it is operated remotely. The remote stations can be made small and compact, and, because they do not require ac power, can be mounted in places where there are no power outlets.

Construction hints

The unit is built into a 5 x 10 x 3-inch steel chassis. All transformers except the input transformer are mounted above the chassis to minimize inductive coupling to the input transformer. While six relays are used in the unit described, more or fewer can be used, depending upon the extent of the system. The small, hermetically sealed relays give long, unfailling service because of their sealed design, but can be replaced with a less expensive type if desired. The unit is obviously more expensive and complex than a typical master station, but it should be remembered that it can do the work of six master stations, and is much more economical to build and operate. END

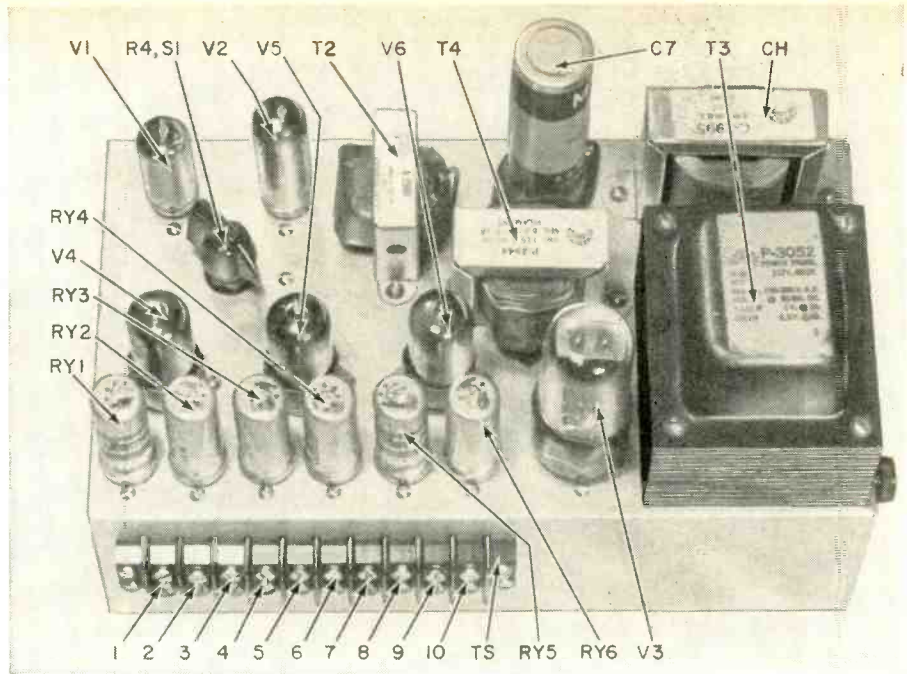

Finished unit fits on 5 x 10 x 3-inch chassis.

Circuit of the versatile unit, with connections for remote unit 1 shown. When other remote units are added, similar connections are made. The only exception is the talk line. It is connected to the respective remote unit terminal.

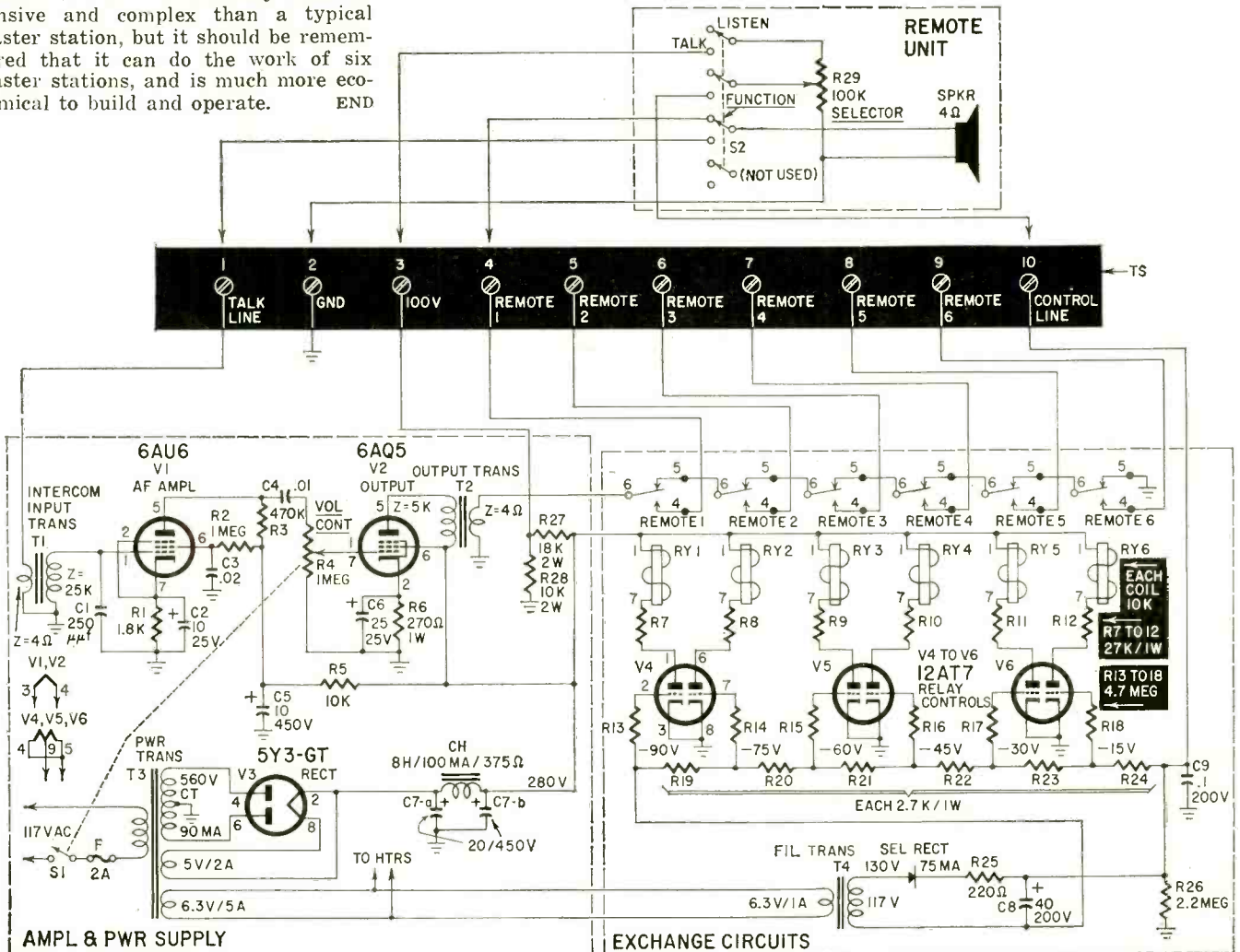

ELECTRONIC JUDGE SPOTS THE WINNER

Time-discriminating circuit picks out the first car across the finish line

By SAM GARSON

INCREASING interest in drag racing and the high speeds of the contestants' autos require an accurate way to determine which of two autos crosses the finish line first. Consider the problem: At well managed drag strips there are two parallel lanes $\frac{1}{4}$ mile long and about 50 feet apart. Two autos start from a dead stop at the starting line and may cross the finish line at 120 mph or faster. This final speed is 176 feet per second, or 2.1 inches per millisecond. It is extremely difficult for a judge standing at the finish line to pick out the winner when the cars are moving that fast and yet are within inches of each other in the forward direction.

This is where the electronic judge comes in. Two pairs of spotlights and photocells are set up at the finish line (Fig. 1). The photocell circuit, which delivers a 20-volt positive-going pulse when the light beam shining on the cell is interrupted, is conventional. The judging (or, more literally, time-discriminating) circuit consists of two 5696 thyratrons in a cross-coupled grid-bias configuration. When either 5696 fires, the other is immediately biased so far negative that it cannot possibly be fired. At the same time a relay closes in the plate circuit of the tube that fires, supplying power to a large red lamp hanging over the lane of the winning auto. Laboratory tests show that the circuit will differentiate between signals arriving at the two tubes as close together in time as 10 μ sec. Therefore, two autos traveling at 120 miles per hour can be as close as .02 inch, and the winner will still be correctly identified. Obviously, dead heats are few and far between!

The simple circuit of the electronic judge (Fig. 2) requires little power.

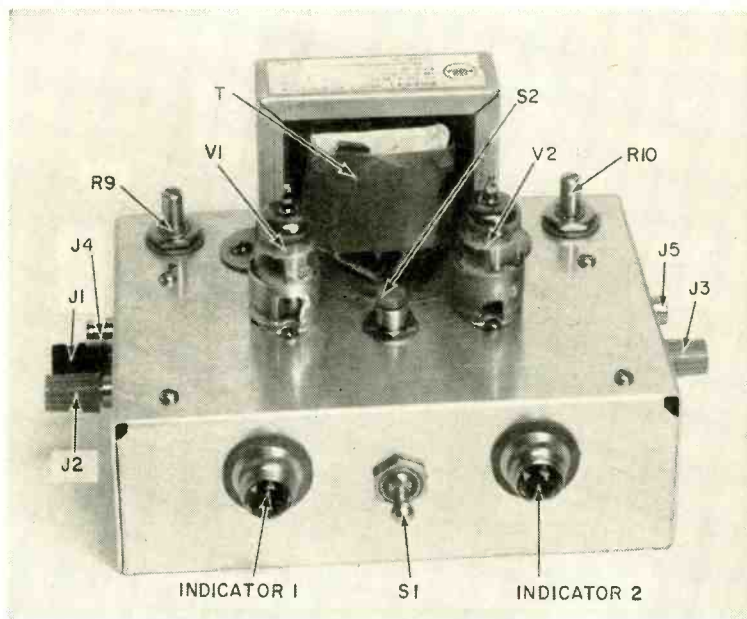

The complete electronic judge. Just hook up to the photocells at the finish line and it is ready to use.

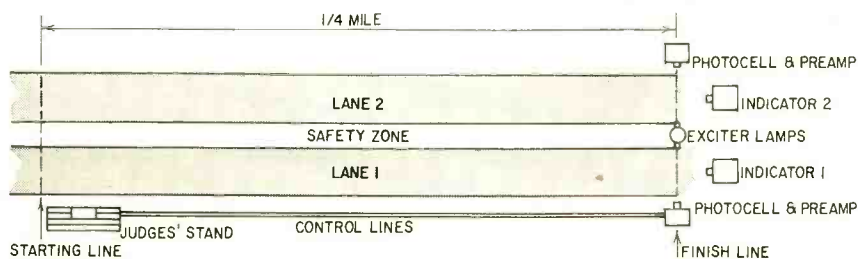

Fig. 1—Equipment layout at a typical drag strip.

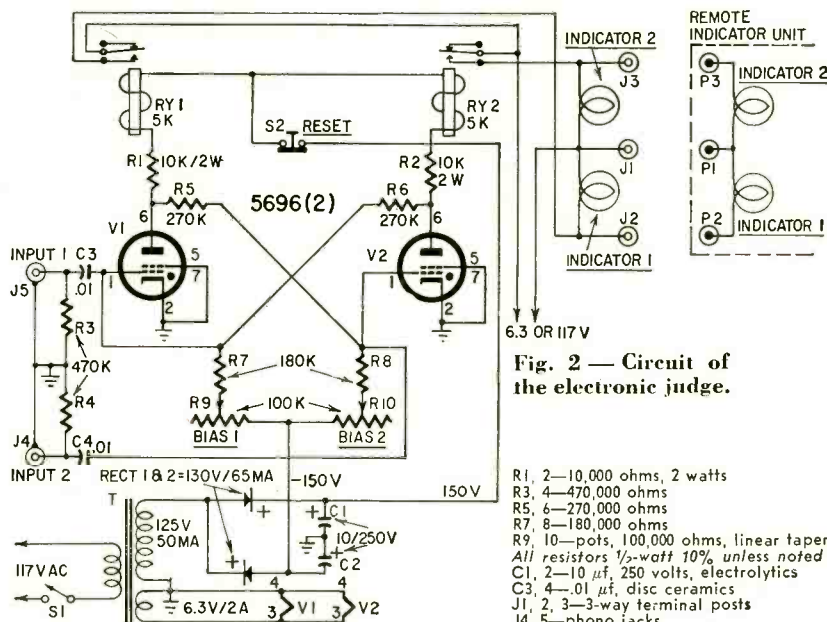

Fig. 2—Circuit of the electronic judge.

- R1, 2—10,000 ohms, 2 watts
- R3, 4—470,000 ohms
- R5, 6—270,000 ohms
- R7, 8—180,000 ohms
- R9, 10—pots, 100,000 ohms, linear taper
- All resistors $\frac{1}{2}$ -watt 10%, unless noted
- C1, 2—10 μ f, 250 volts, electrolytics
- C3, 4—.01 μ f, disc ceramics
- J1, 2, 3—3-way terminal posts
- J4, 5—phono jacks
- P1, 2, 3—connectors to fit J1, 2, 3
- RECT 1, 2—selenium rectifiers; 130 volts, 65 ma
- RY 1, 2—spdt plate relay; 5,000-ohm 6.3-ma coil (Potter & Brumfield LB-5 or equivalent)
- S1—spst toggle
- S2—spst pushbutton, normally closed
- T—power transformer; primary, 117 volts; secondary, 125 volts, 50 ma; 6.3 volts, 2 amps (Stancor PA-8421 or equivalent)
- V1, 2—5696 thyatron
- Chassis, 6 x 4 x 2 inches
- Sockets, 7-pin miniature (2)
- Miscellaneous hardware

So the power supply consists of only a small transformer and two selenium rectifiers in a full-wave voltage-doubler arrangement delivering 150 volts positive and negative. The control grids of the 5696's are held at -10 volts by the cross-coupled voltage dividers made up

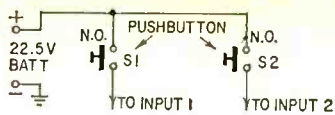

Fig. 3—Auxiliary triggering circuit to test reaction time.

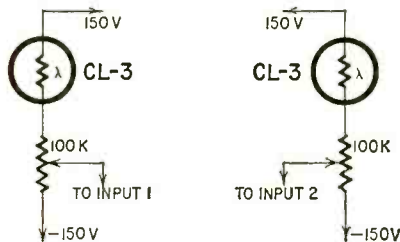

Fig. 4—Another alternative triggering circuit.

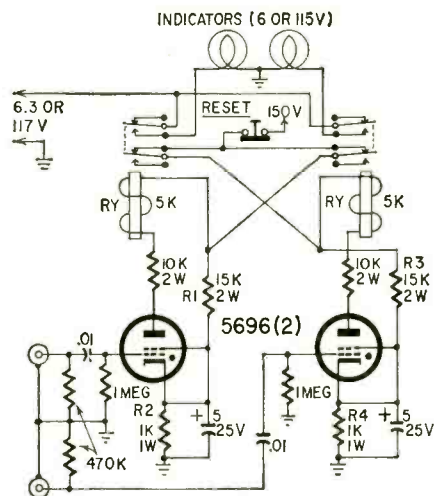

Fig. 5—A simpler, but less accurate, time-discriminating circuit. R1, R2 and R3, R4 are voltage dividers designed to bias the cathodes. Use isolation transformer to supply indicator lamps.

of R5, R8, R10 and R6, R7 and R9. R9 and R10 are adjusted for proper bias.

As soon as a pulse arrives at a control grid, say V1, the tube fires. Its plate voltage drops to about 10, and V2's grid drops to -75, rendering it completely insensitive to any signals below about 73 volts. Relay RY1, having closed, supplies 117 or 6.3 volts to J2, which powers the red lamp suspended above lane 1 at the finish line. (If more power is needed, use 117 volts ac for the lamps. Simply disconnect the 6.3 volts from the relay and connect to the ac line input through an isolation transformer. Use 115-volt lamps.)

Indicator 1 lights up on the panel of the instrument, for the information of those in the judges' stand. The circuit remains in this condition until reset button S2 is pressed. This removes B-plus from both tubes, extinguishes the indicator lamps and, when the button is released, both grids are again at -10 volts and ready for the next event.

In use, the instrument is located in the judges' stand at the starting line, the 20-volt pulses having been sent over telephone cable from the finish line. We found it necessary to put cathode followers between the photocell circuit and the telephone cable for impedance

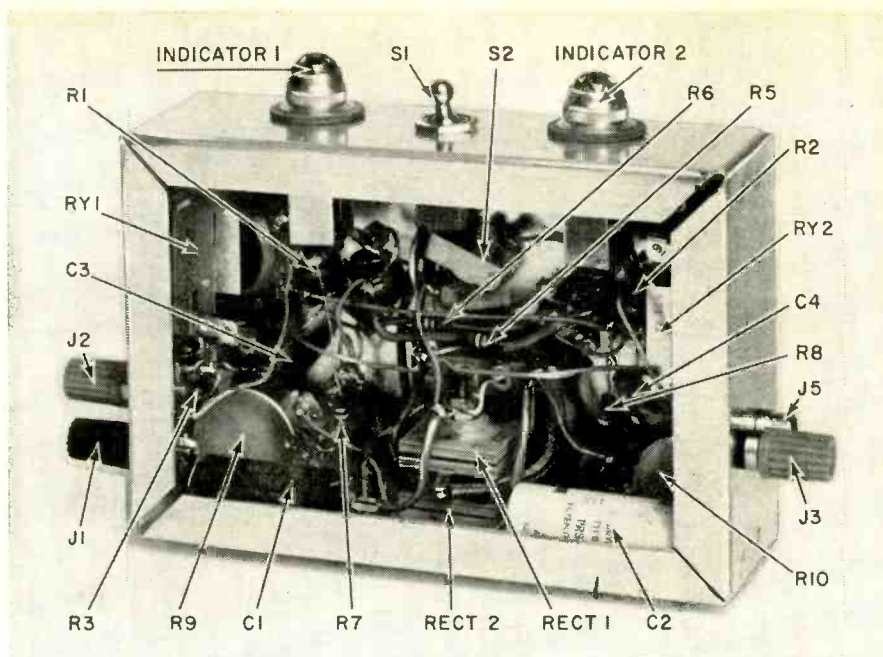

Underchassis layout is less complex than it looks.

matching, to preserve the rise time of the output pulse from the photocell. We used 6.3-volt indicator lamps in the unit shown in the photos. If 115-volt lamps are needed for greater visibility at the finish line, you can control them with 6-volt ac relays tied in through J1, 2 and 3, or you can use 115-volt lamps throughout.

Aside from this very practical application to sporting events, the home electronics gadgeteer can adapt this circuit to all sorts of games. For example, one can compare the reaction times of two persons by having each one press his switch at a given signal (Fig. 3). Or you can construct two flashlight guns and let your young cowboys and cowgirls draw against each other. Let each one have his or her own target, consisting of a photocell (Fig. 4). At a given signal, each draws and shoots. As soon as a target is hit, a

positive pulse fires the appropriate thyatron and the winner is immediately indicated. Adjust the pots for your own particular lighting conditions so that the voltage change at the 5696 control grid will be about 20 volts when the flashlight beam hits the photocell.

Note that the circuit of Fig. 5 is somewhat simpler, since no B-minus is necessary. When V1 fires, two of the normally closed contacts on the relay remove B-plus from V2's plate circuit, and thereby prevent it from firing. However, tests with sensitive relays show that the opening times of these contacts were nonreproducible and varied by as much as 2 or 3 milliseconds. The final circuit (Fig. 2) has an almost infinitesimal dependence on relay characteristics.

Undoubtedly, the home experimenter can devise many other interesting uses for this simple and reliable circuit. END

Reverberation Improved

Improvements in artificial reverberation promise to facilitate conversion of an ordinary auditorium into the acoustic equivalent of a full-sounding concert hall.

"Colorless" artificial reverberation is being developed jointly by Dr. M. R. Schroeder ("Stop Feedback in PA Systems," R-E, February 1960) and Mr. B. F. Logan of the Bell Laboratories.

Artificial reverberation has been used by recording companies, broadcasters and room acousticians for many years before its recent upsurge in packaged hi-fi equipment. A typical user might be a radio station wishing to broadcast a recording of an outdoor concert or open-air summer music festival. At the broadcast studio, an artificial reverberator would introduce reverberations,

or echoes, to imitate the fullness of indoor performance.

Another application is acoustic conversion of public or private auditoriums lacking in reverberation because they are designed primarily for speech. When artificial reverberation is thus employed, no changes in architecture and interior decoration are required.

Bell Laboratories' colorless artificial reverberation, Messrs. Schroeder and Logan report, represents a significant advance over that produced by presently obtainable equipment because it does not alter the sound's tone color (timbre). It reproduces all sound, music or vocalization or both, with equally high quality similar to the effect of a real concert hall. Nor does colorless reverberation add unpleasant distortions of its own to the original sound.

A PROPHECY

For men and women with a sincere desire to succeed



"In the years that have passed since my days on the faculty of RCA Institutes, I have become even more firmly convinced that the individual who continues his education . . . particularly his technical education . . . is the individual who profits both as a thinking man and as a working man. Science and industry will reward you for your talents and energy. Out of your efforts may come inventions, new products, processes and services. There is everything good yet to be accomplished in our lives and in our work. What man has done, man can do better."

David Sarnoff

Chairman of the Board,
Radio Corporation of America

RCA Institutes Offers the Finest of Home Study and Resident Training for Your Career in the Rapidly Expanding World of Electronics

RCA Institutes, founded in 1909, is one of the largest technical institutes in the United States devoted exclusively to electronics. A service of Radio Corporation of America, RCA Institutes offers unparalleled facilities for technical instruction . . . tailored to your needs. The very name "RCA"

means dependability, integrity, and scientific advance.

RCA Institutes Home Study School, licensed by the New York State Department of Education, offers a complete program of integrated courses for beginners and advanced students rang-

ing from electronic fundamentals to automation. All courses are designed to prepare you for a rewarding career in the rapidly expanding world of electronics. *The caliber of the training you receive is the finest!* And you get top recognition as an RCA Institutes graduate!

START YOUR CAREER TRAINING IN THE RAPIDLY EXPANDING WORLD OF ELECTRONICS

RCA INSTITUTES
offers
HOME STUDY COURSES
and
**RESIDENT SCHOOL
COURSES**
in New York City
and Los Angeles



**SEND
THIS
POSTCARD
FOR
FREE
BOOK**

**FILL OUT,
DETACH, AND
MAIL TODAY**



RCA INSTITUTES, INC., Dept. RE-11
Schools of Television and Electronic Technology
A Service of Radio Corporation of America
350 West Fourth Street, New York 14, N. Y.
610 South Main Street, Los Angeles 14, Calif.

Please rush me the FREE illustrated book checked below. I understand that I am under no obligation and that no salesman will call.

Home Study School Resident School New York
Resident School Los Angeles

Name _____
(Please Print)

Address _____

City _____ Zone _____ State _____

Korean Vets: Enter Discharge Date _____

CANADIANS: Take advantage of these same RCA Institutes Home Study Courses at no additional cost. No postage, no customs, no delay. Fill out this card and send in envelope to: RCA Victor Limited, 5581 Royalmount Ave., Montreal 9, Que.



RCA Institutes offers the finest of training for your career in Electronics

*Learn how you can take advantage
of this opportunity*

SEND POSTAGE-FREE CARD FOR FREE BOOK TODAY.

BUSINESS REPLY MAIL

No Postage Stamp Necessary if mailed in U. S.

Postage will be paid by —

RCA INSTITUTES, INC., Dept. RE-11
350 West Fourth Street
New York 14, N. Y.

FIRST CLASS
PERMIT NO.
10662
NEW YORK, N. Y.



HOME STUDY COURSES *in* *Electronic Fundamentals • TV Servicing* *Color TV • Electronics for* *Automation • Transistors*

Pay-Only-As-You-Learn With No Further Obligation. All RCA Institutes Home Study courses are available under the liberal "Pay-As-You-Learn" Plan. This plan affords you the most economical possible method of home study training, *because you pay only for lessons as you order them . . . one study group at a time!* If you drop out at *any* time, for *any* reason, you do not owe RCA Institutes one penny. No other obligations! No monthly installment payments!

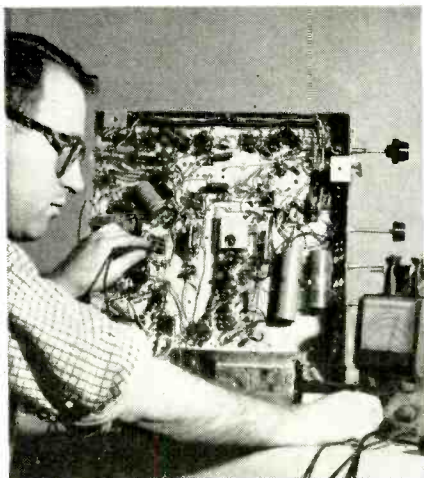

RCA Instruction is Personal. With RCA Home Study training you set *your own pace* in keeping with *your own ability*, finances, and time. The Institutes allows you ample time to complete the course. Your lesson assignments are individually graded by

technically trained personnel, and helpful comments are added where required. You get theory, experiment, and service practice beginning with the very first lesson. All lessons are profusely illustrated. You get *a complete training package* throughout the entire course.

You Get Prime Quality Equipment. All kits furnished with the course are complete in every respect, and the equipment is top grade. You keep all the equipment furnished to you for actual use on the job . . . *and you never have to take apart one piece to build another!*

★ ★ ★

RESIDENT SCHOOLS *in* *Los Angeles and* *New York City* train *you for any field of* *Electronics you may* *choose!*

No Previous Technical Training Required For Admission. RCA Institutes Resident Schools in Los Angeles and New York City offer training that will prepare you to work in re-

warding positions on research and production projects in fields such as automation, communications, technical writing, television, computers, and other industrial and advanced electronics applications. Even if you did not complete high school, RCA will prepare you for such training with courses specially designed to provide the basic math and physics required for a career in electronics.

Free Placement Service. RCA Institutes graduates are now employed in important jobs at military installations such as Cape Canaveral, with important companies such as IBM, Bell Telephone Labs, General Electric, RCA, and in radio and TV stations all over the country. Many other graduates have opened their own businesses. A recent New York Resident School class had 92.06% of the graduates who used the Free Placement Service accepted by important electronics companies . . . *and had their jobs waiting for them on the day they graduated!*



Coeducational Day and Evening Courses. Day and Evening Courses are available at Resident Schools in New York City and Los Angeles. You can prepare for your career in electronics while continuing your normal full-time or part-time employment. Regular classes start four times each year.



**SEND POSTCARD FOR FREE
 ILLUSTRATED BOOK TODAY!
 SPECIFY HOME STUDY OR
 RESIDENT SCHOOL**

RCA INSTITUTES, INC. A SERVICE OF RADIO CORPORATION OF AMERICA, 350 W. 4th St., New York 14, N. Y., 610 S. Main St., Los Angeles 14, Calif.



The Most Trusted Name in Electronics

NEW short-range Communicator

All-transistor wireless microphone may offer substantial improvement in short-wave communication and control



The Vega-Mike wireless microphone.



The FM receiver.

By C. ARTHUR FOY

VEGA-MIKE* is essentially a small FM broadcasting station which transmits to a tuned receiver at a central location. The all-transistor microphone-transmitter is battery-powered and completely self-contained. The receiver is small and can be either portable or rack-mounted. Vega-Mike can be used for either relaying information, direct broadcasting over commercial radio, public address or actuating a variety of auxiliary systems including tape recorders. It offers broadcast-quality transmission of sound over distances ranging from as little as 25 feet to more than ½ mile, depending upon environmental conditions.

Under development for more than 3 years, Vega-Mike had its origin in the classrooms of San Jose State College in California. Here Mr. Ray Litke of the Audio-Visual Department was assigned

by his department head, Dr. Richard Lewis, to develop some method of wireless transmission of the voice which would enable a teacher to lecture to his classes in a large auditorium or feed audio to a closed-circuit TV system for his teacher-observation program, and to be able to do it without the inconvenience of trailing wires.

Subsequent development by Vega Electronics resulted in a completely miniaturized broadcast station con-

tained in a cylindrical unit only 1 inch in diameter by 5½ inches long, with the antenna external to the structure.

The Vega-Mike system is designed for the professional user who requires the dependability and quality of a standard microphone without the inconvenience of an interconnecting microphone cable. It operates at authorized FCC frequencies in the 25- to 45-mc band.

There are three models: a hand-held unit with a telescoping whip antenna attached to a swivel joint at the base; a modification of the hand-held model in which the antenna is attached to the top of a helmet—as shown on the cover—for better transmission in crowded situations or over longer distances, and a lavalier model worn around the neck, with the suspending cord acting as the antenna.

Uses to which the system can be put are limited only by the range of the system and the imagination of the operators. Recently, Vega-Mike scored in the field of reporting when it was used by the news-gathering staff of the American Broadcasting Co. at the two major political conventions. It is also applicable to such diverse fields as sports broadcasting, security police, watchmen making their rounds, regular police work, fire department control and emergency direction, the entertainment field—freeing performers from the limitation of conventional microphone systems, baby-sitting, public-address broadcasting, and many more.

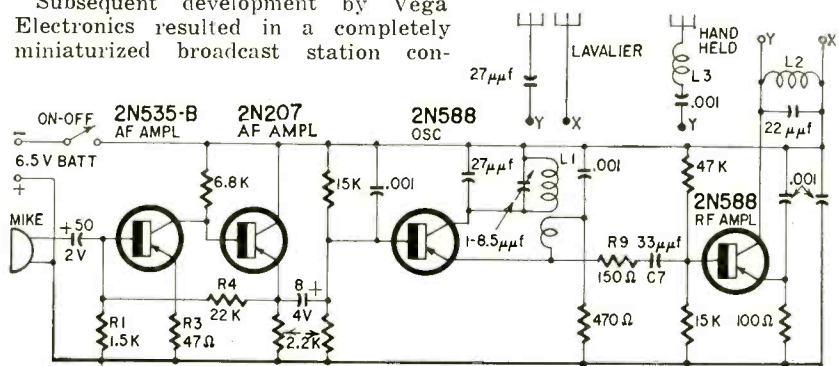

Fig. 1—Hand-held transmitter uses four transistors.

*Trademark Vega Electronics Corp., Cupertino, Calif.



FREE!

Olson Radio Catalogs FOR ONE YEAR

- ★ 8 Different Issues
- ★ All Bargain Packed



FREE One Year Subscription to OLSON RADIO'S Fantastic Bargain Packed Catalog—Unheard of LOW, LOW WHOLESALe PRICES on Brand Name Speakers, Changers, Tubes, Tools, Hi-Fi's, Stereo Amps, Tuners and other Bargains.

Another OLSON Bargain!

6 TRANSISTOR RADIO

With Battery, Earphone & Case

\$16⁸⁸

2 for \$32.00
No. RA-373

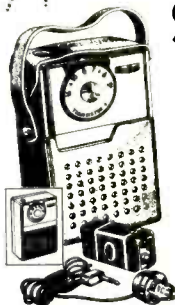

6 transistors and germanium diode in powerful superheterodyne circuit—a total of 7 semiconductors. Features: push-pull audio output, tunes standard broadcast band. Built-in PM speaker, personal earphone jack, and finest imported leather carrying case. Plays anywhere; plane, train, bus, auto, etc. Size 2-2/3" W x 4-1/2" H.

9 VOLT RECHARGEABLE BATTERY & CHARGER

Recharges Battery Overnight
Plays 12-15 Hours

\$2⁶⁹

No. BA-74

MAIL COUPON TODAY

Fill in coupon below for your FREE one year subscription to Olson's Bargain Packed Catalog. To order above merchandise, simply check quantity desired and send remittance along with coupon. (Include enough for postage or parcel post shipment. Send \$2.00 deposit for C.O.D. orders.)

- FREE Olson Catalogs for One Year
- No. RA-373 Radio @ \$16.88 Ea.
- 2 for \$32.00
- No. BA-74 Battery & Charger \$2.69

NAME _____

ADDRESS _____

CITY _____ ZONE _____ STATE _____

OLSON RADIO CORPORATION

715 S. Forge St., Akron 8, Ohio

be either portable or rack-mounted. The portable model is 6 3/4 x 9 3/8 x 12 5/8 inches in exterior dimensions; the rack-mounted receiver is 19 x 10 1/2 x 11 3/4 inches. All controls except squelch sensitivity are on the front of the panel. The portable receiver has a carrying handle, a telescoping antenna mounted on a ball swivel and recessed in the case when not in use and a monitor speaker on the left side, or with a carrying handle and a 72-ohm antenna connector for an external antenna as well as the speaker on the left side. The rack-mounted receiver has a connection for a 72-ohm antenna and the monitor speaker mounted in the panel.

The power switch and MONITOR GAIN (volume) control are located on the lower right of the panel. The tuning

signed to have good inherent stability, operates at 10.7 mc above the signal frequency. The oscillator signal is injected into the grid of the mixer through a capacitor. The second half of the oscillator envelope is used as a reactance tube to provide automatic frequency control. The triode mixer provides the 10.7-mc signal to feed the if amplifiers, of which there are two. These stages are followed by a limiter, the grid return of which provides the avc voltage.

The ratio-detector transformer drives a pair of matched semiconductor diodes. All the small components of this ratio detector are encapsulated in a ceramic package. This provides greater uniformity and freedom from radiation and regeneration than individual component

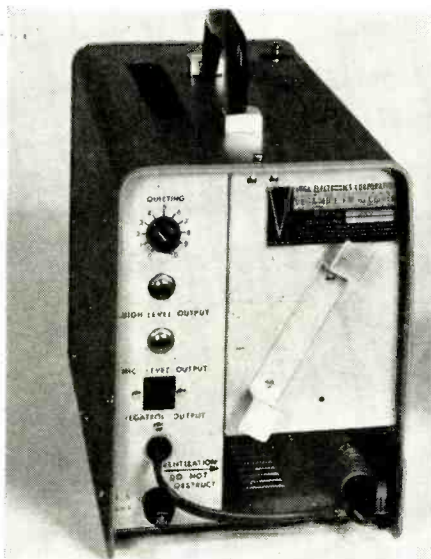

How receiver looks from rear.

dial, graduated in megacycles from 25 to 45, has a 3-to-1 reduction drive for precision tuning. At the lower left a spring-return afc and squelch-defeat switch allows fine tuning. The eye at the top of the panel gives visual indication of a correctly tuned carrier signal.

Generally speaking, the circuit design is conventional. However, the elements of the input circuit are arranged with care, and the antenna loading is optimized. These are items contributing in large measure to the sensitivity.

The receiver utilizes a 25-45-mc continuous-tuning FM band with 10.7 if and afc.

It has a complement of 11 tubes and 2 diodes (two 6BK7, three 6AU6, one 6AB4, one 6FG6/EM84, one 6V4/EZ80, one 6CL6, one 6CG7, one 6U8 and two 1N542). The cascode input amplifier feeds a triode mixer. A small parasitic suppression coil is used to permit maximum gain in the input stage. Automatic gain control is supplied by a negative signal derived from the limiter grid and applied to the input grid through a filter and isolating resistor. The cascode plate is shunt fed through a coil to allow optimum placement of the tuned circuit elements. The Hartley oscillator, de-



The Vegatrol relay control unit.

construction would provide. A small four-pin socket provides test points at four critical places in the circuit and simplifies alignment.

The afc signal is derived from the ceramic package of the ratio detector. It is filtered and applied to the grid of the reactance tube. The PRESS-TO-TUNE switch on the front panel allows the afc signal to be shorted to ground so that the center of the carrier may be more accurately tuned. This switch also defeats the squelch or quieting circuit so that the faintest signals can be sought. The audio output circuit is a gated amplifier and cathode follower.

Two separate audio circuits are incorporated with connections to the rear of the receiver. One branch, through its own power tube and output transformer, furnishes 1 watt to drive the small (4 x 6-inch) built-in monitor speaker. The monitor level in this circuit is controlled by the gain control on the front panel. A jack, also on the front panel, for headphones, cuts out the speaker when the phone plug is inserted. The main audio output branch features a fixed "line"-level, low-impedance cathode-follower output. This output is 2 volts from a signal deviated ±20 kc.

A fixed pad gives a second or "mike" level output at .001 volt from the same

input signal level. Thus the output of the receiver may be used to feed a large variety of standard sound reinforcement amplifiers, tape recorders or radio-station input consoles.

Quieting control

The entire system is equipped with a quieting control (squelch) which eliminates any of the unusual rushing noises heard when the incoming signal is eliminated in an FM system.

The quieting signal (squelch) has an adjustable sensitivity with the control in the rear of the receiver.

Receiver audio response is flat from 20 cycles to 20 kc down 3 db at 14 cycles and 60 kc. The signal-to-noise ratio is better than 60 db for 20-kc deviation, unmodulated carrier.

Since this is an FM system, the strongest radio-frequency signal on the receiving antenna will override and tend to block out all other signals on the same frequency. Therefore, it is not possible to receive signals from two Vega-Mikes simultaneously if they are transmitting on the same frequency. The solution, under these circumstances, is to turn the power off on the one not being used. Thus, two or more transmitters may be used on the same frequency if only one is turned on at any one time.

Several transmitters may be used with one receiver if they are on different frequencies, each one being tuned in separately. Any number of receivers may, of course, be tuned to receive the signal of one transmitter at the same time without any problem.

The receiver can be set up in any convenient operating position by plugging it into any convenient power source of 117 volts, 50-60-cycle ac power. The receiver can also be connected to a suitable input of the associated power amplifier, tape recorder, mixer console, etc. Two outputs are available: (a) high level—output approximately 2 volts for feeds to line inputs (bridging), "phono inputs," etc. and (b) low level—similar to usual cabled microphone output (-40 db) to feed mike input on amplifier, mixer or tape recorder. (Unbalanced 150-ohm may be fed to either low- or high-impedance inputs.)

To operate the receiver, the operator merely extends the telescoping antenna whip to its fullest extent and turns the power on by rotating the gain-control knob to the right. This knob also controls the volume level of the built-in monitor speaker or head-phones, when used, but *does not* affect the volume level of the high-level or low-level outputs, which are fixed.

If the receiver is turned on a few minutes before the system is to be used, the operating stability will be somewhat improved.

Tuning the receiver is simple. The operator first notes the frequency allocation as stamped on the microphone nameplate. The Vega-Mike is then held or worn as it would normally be in use and turned on. The main tuning dial on the receiver is rotated to the approximate frequency of the microphone. The

with **ASSEMBLY MANUALS**



and **ENGINEERING**

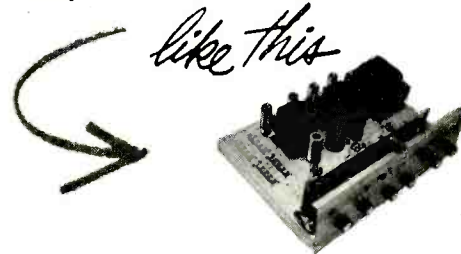

and **STYLING**



and **SAVINGS**

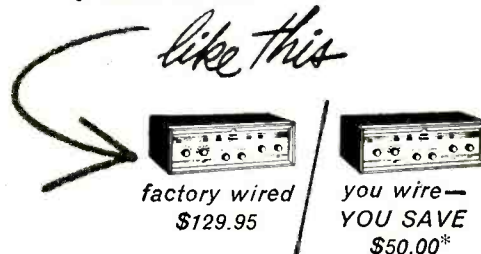

is it any wonder...

THAT **PACO**
HIGH FIDELITY KITS
OUTSELL
FACTORY-WIRED
COMPONENTS

20 to 1!



MODEL SA-40
40-watt stereo preamp-amplifier in kit form. Harmonic distortion, less than 0.5%. 14 controls. Hum and noise inaudible.
MODEL SA-40—Kit \$ 79.95
MODEL SA-40W—Wired \$129.95

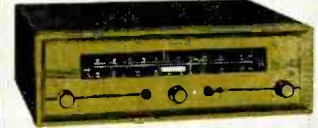

MODEL ST-45
AM-FM SIMULCAST stereo tuner in kit form. Sensitivity—2 μ v for 30 db quieting. MPX facilities.
MODEL ST-45—Kit \$84.95
MODEL ST-45PA—Semi-Kit, with AM and FM tuner sections wired, prealigned and calibrated. . . \$99.95
MODEL ST-45W—Wired, aligned, calibrated, ready to operate. . . \$134.95



MODEL ST-35
FM TUNER KIT. Sensitivity, 2 μ v for 30 db quieting. Easily adapted for MPX and stereo.
MODEL ST-35—Kit \$59.95
MODEL ST-35PA—Semi-Kit, tuner section wired, prealigned. . . \$69.95
MODEL ST-35W—Wired, aligned, calibrated, ready to operate. . . \$89.95



MODEL L-2
2-WAY, SPEAKER-SYSTEM SEMI-KIT. 10" Jensen woofer and horn-type tweeter. Response, 45 cps to 15 Kc. 23 1/2" W x 13" D x 12" H.
MODEL L-2U—unfinished birch \$59.95
MODEL L-2F—walnut, furniture-finished. \$69.95

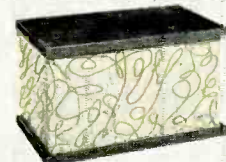

MODEL L-1
ULTRA-COMPACT SPEAKER SYSTEM SEMI-KIT. Excellent sound in minimum space. Response, 50 to 14,000 cps. 15 1/2" W x 9 1/4" D x 8 1/2" H.
MODEL L-1U—sanded (unfinished) walnut \$24.95

At leading hi-fi dealers and electronic distributors . . . where you can also see the complete line of PACO test, marine and ham equipment kits.

For complete catalog, write:

PACO
ELECTRONICS CO., INC.

Kit Division of
PRECISION Apparatus Company, Inc.
70-31 84th Street, Glendale 27, L. I., N. Y.
(Subsidiaries of PACOTRONICS, Inc.)



The Beautiful *Schober* CONSOLETTA —only small organ with two full 61-note keyboards and 22 stops. Requires only 24 3/2" floor space! Commercial value approximately \$1600 or more.

BUILD THIS SUPERB *Schober* ORGAN FROM SIMPLE KITS and save over 50%

Give Your Family A Lifetime of Musical Joy With A Magnificent Schober Electronic Organ!

Now you can build the brilliant, full-range Schober CONSOLETTA or the larger CONCERT MODEL with simple hand tools! No skills are needed; no wood-working necessary. Just assemble clearly marked electronic parts guided by step-by-step instructions. You build from kits, as fast or as slowly as you please . . . at home, in your spare time — with a small table serving as your entire work shop.

Pay As You Build!

Start building your organ at once, investing just \$18.94! The superb instrument you assemble is as fine, and technically perfect, as a commercial organ . . . yet you save over 50% on quality electronic parts, high-priced labor, usual store mark-up!

Free Booklet

Send for 16-page booklet in full color describing Schober organs you may build for home, church or school — plus articles on how easy it is to build your own organ and how pleasant it is to learn to play. Also available is 10" LP demonstration record (price \$2.00 — refundable on first order). Send for literature. No obligation and no salesman will call.

THE GREAT CONCERT MODEL meets specifications of American Guild of Organists

Mail This Coupon For FREE Schober Literature And Hi-Fi Demonstration Record TODAY!

The Schober Organ Corp., Dept. RE-9
43 West 61st St., New York 23, N. Y.

- Please send me the FREE Color Booklet and other literature on the Schober organs.
- Please send me the 10" hi-fi Schober demonstration record. I enclose \$2.00 (refundable on receipt of my first kit order).

Name.....

Address.....

City..... Zone..... State.....

operator then depresses the PRESS-TO-TUNE button and, while rotating the tuning dial, observes the tuning eye at the top of the panel, tuning to smallest closing of the eye pattern. The operator then releases the tuning button and the receiver is locked onto the transmitter FM output signal and the system is ready for use.

Many professional users require a 150-ohm balanced output from the receiver instead of the unbalanced output normally supplied. The system can easily be modified in the field by adding

The energy absorbed by the body is harmless, as it is only a few thousandths of a watt. Removal of either element from the lavalier model will result not only in lower efficiency but, more important, will shift the radiation from its assigned frequency, thus causing the device to be operated illegally.

Use in automobiles

The Vega-Mike can be used from automobiles both for communications radio, such as police radio, and for the actuation of auxiliary systems through

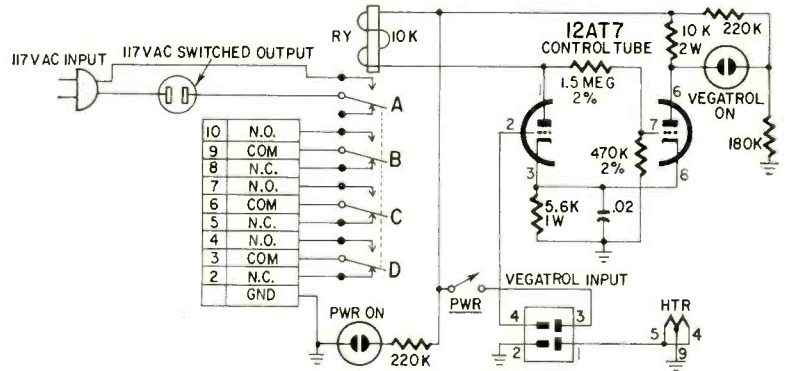

Fig. 3—The Vegatrol greatly extends the system's usefulness.

a few parts: one transformer (UTC A-24), two connectors (tip ring, sleeve phone jack or Cannon type XL), two resistors of 3,300 ohms, and one resistor of 150 ohms.

The antennas

The antenna for the hand-held models is a telescoping whip mounted on a swivel at the base of the housing. This antenna should be extended to its full-length (22 3/4 inches) for the most efficient operation. Under certain conditions it may be used in a telescoped condition (5 3/4 inches).

The accessory helmet is designed to accommodate the hand-held antenna, which is removed from the hand-held model by unscrewing the antenna, attaching it to the helmet top and connecting the helmet cable to the hand-held mike where the antenna was removed. This accessory extends the range of the system as the antenna is farther away from the body.

The antenna for the lavalier model is a two-element system comprised of conducting cords attached at one end to the transmitter and having a hook on the other end to engage an eye on the case. One element is used to support the Vega-Mike about the neck, lavalier-fashion; the other may be coiled and placed in the pocket or in the shirt front for short-range transmission (25 to 50 feet). For greater ranges (up to several hundred feet), the longer element should be looped about the waist and hooked to itself with the hook on the cord end.

The human body absorbs some of the radiated energy from the antenna, and the two-element system yields the necessary increase in radiation efficiency to obtain the optimum transmission range.

the use of the Vegatrol*. It is interesting to note, that, since the rf emitted from the system is FM, the interference with the receiver from the ignition system is minimized, if even discernible.

Any mobile power source capable of delivering 65 watts at 117 volts, 50-60 cycles, may be used to power the receiver. The receiver may be placed on the seat with the antenna pulled out and rotated to project out of the window. Better results will be obtained if the receiver is placed on the hood or on top of the car outside the metal body.

The Vegatrol

A unique accessory of the system is the Vegatrol, basically a carrier-operated, four-pole double-throw relay (Fig. 3). With this accessory it is possible for an operator to start and stop a variety of accessory instruments or related items by remote control. When the transmitter and receiver are properly tuned and the quieting control (squelch) is set properly, the relay in the Vegatrol accessory can be energized by turning the Vega-Mike control to on and de-energized by turning to off.

The Vega-Mike can thus control such external circuits as cuing lights (for example, "On the Air"), a variety of tape recorders (starting, placing in recording mode and stopping), and closing or opening other relay control circuits such as remote-controlled radio transmitters, floodlights and the like.

Vega-Mike's unique design and operating characteristics offer a wide variety of advantages to those desiring a high-quality wireless microphone with a range of up to 1/2 mile. It is a system that not only performs as a wireless mike but, with the addition of the Vegatrol relay, can function as a wireless remote control as well.

END

Circuit substitution

The old reliable method, with a few new wrinkles, can solve your transistor service problems

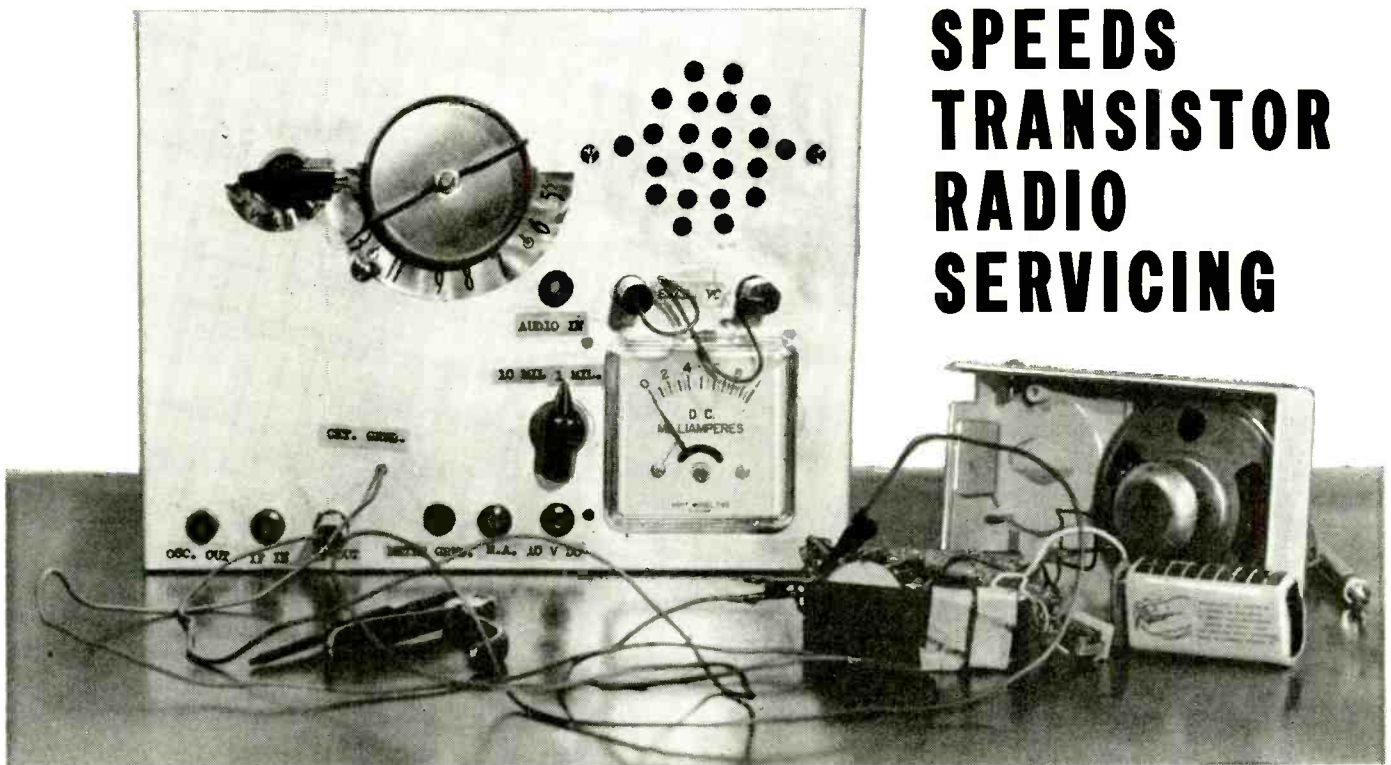

SPEEDS TRANSISTOR RADIO SERVICING

By C. J. BORLAUG *

CIRCUIT substitution is by no means a revolutionary new way of servicing electronic equipment. It has been used with great success for years. The old Chanalyst and Analyst that have been on the shelf in the back room for many years prove that. Unused and gathering dust now, they were once standard pieces of equipment in the well equipped radio service shop.

We have since learned so much about the simple four- or five-tube AM radio circuit that we can service radios by tapping grids and arcing plates and screens (on the really tough radio problem we might even use a volt-meter!).

But we are not familiar with the transistor radio. Maybe we should dust off the old Chanalyst and put it back

in service! Actually, it will do the job, but if we are to be completely successful with this method of servicing, we will have to substitute transistor circuitry for our circuit checker, then use some of the same old methods.

The reasons for *not* using vacuum-tube equipment for circuit substitution lie in the difference in voltages, circuit impedances and signal levels between tube and transistor circuits. Your investment in a transistor circuit-substitution checker would be a transistor radio chassis (Fig. 1). A suggested panel layout is shown in Fig. 2; the optional meter circuit is shown in Fig. 3. Any good operating transistor radio chassis will do the job. You will find a chassis with a separate oscillator transistor a definite advantage over one using an autodyne converter. The oscillator output can be used to better advantage in checking inoperative oscillator circuits.

Transistors are essentially current-

operated devices and the best way to service a transistor circuit is to check current. An accurate 1-ma and 10-ma meter is very convenient. The meter circuit could easily be expanded to other ranges of voltage and current by adding shunt and series resistance and changing the switching arrangement. The meter is calibrated with batteries, a variable resistor and a known accurate meter for comparison.

To convert the transistor radio chassis to a circuit-substitution checker, it is necessary to couple in and out of the circuits with external jacks as shown in Fig. 1. Circuit ground would be the chassis ground of the radio.

Making a schematic work

If we are going to service an inoperative transistor radio, the diagram of the inoperative set would be roughly the same as that of the substitution checker. To eliminate an additional diagram we

(Continued on page 88)

*District service manager, Sylvania Home Electronics Corp.

EXAMINE ANY OF THESE TESTERS BEFORE YOU BUY!!

Yes, we offer to ship at our risk one or more of the testers described on these pages.

SUPERIOR'S NEW MODEL 770-A

VOLT-OHM MILLIAMMETER



FEATURES:

- Compact—measures 3 1/8" x 5 7/8" x 2 1/4".
- Uses "Full View" 2% accurate 850 Microampere D'Arsonval type meter
- Housed in round-cornered, molded case.

SPECIFICATIONS:

- 6 A.C. VOLTAGE RANGES: 0-15/30/150/300/1500/3000 Volts.
- 6 D.C. VOLTAGE RANGES: 0-7.5/15/75/150/750/1500 Volts.
- 2 RESISTANCE RANGES: 0-10,000 Ohms. 0-1 Megohm.
- 3 D.C. CURRENT RANGES: 0-15/150 Ma., 0-1.5 Amps.
- 3 DECIBEL RANGES: -6 db to +18 db, +14 db to +38 db, +34 db to +58 db.

The Model 770-A comes complete with test leads and operating instructions. Price is \$15.85. Terms: \$3.85 after 10 day trial then \$4.00 monthly for 3 months.

SUPERIOR'S NEW MODEL 79

SUPER-METER

WITH NEW 6" FULL VIEW METER

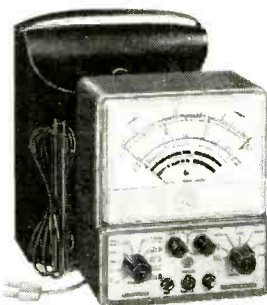

SPECIFICATIONS:

- D.C. VOLTS: 0 to 7.5/15/75/150/750/1,500.
- A.C. VOLTS: 0 to 15/30/150/300/1,500/3,000.
- D.C. CURRENT: 0 to 1.5/15/150 Ma. 0 to 1.5/15 Amperes.
- RESISTANCE: 0 to 1,000/100,000 Ohms. 0 to 10 Megohms.
- CAPACITY: .001 to 1 Mfd. 1 to 50 Mfd.
- REACTANCE: 50 to 2,500 Ohms, 2,500 Ohms to 2.5 Megohms.
- INDUCTANCE: .15 to 7 Henries. 7 to 7,000 Henries.
- DECIBELS: -6 to +18, +14 to +38, +34 to +58.

The following components are all tested for QUALITY at appropriate test potentials. Two separate BAD-GOOD scales on the meter are used for direct readings.

- All Electrolytic Condensers from 1 MFD to 1000 MFD.
- All Selenium Rectifiers. All Germanium Diodes.
- All Silicon Rectifiers. All Silicon Diodes.

Model 79 comes complete with operating instructions, test leads and carrying case. Price is \$38.50. Terms: \$8.50 after 10 day trial then \$6.00 monthly for 3 months.

SUPERIOR'S NEW MODEL 77

VACUUM TUBE VOLTMETER

WITH NEW 6" FULL VIEW METER



Compare it to any peak-to-peak V.T.V.M. made by any other manufacturer at any price!

SPECIFICATIONS:

- DC VOLTS—0 to 3/15/75/150/300/750/1500 volts at 11 megohms input resistance.
- AC VOLTS (RMS)—0 to 3/15/75/150/300/750/1500 volts.
- AC VOLTS (Peak to Peak)—0 to 8/40/200/400/800/2000 volts.
- ELECTRONIC OHMMETER—0 to 1000 ohms/10,000 ohms/100,000 ohms/1 megohm/10 megohms/100 megohms/1,000 megohms.
- DECIBELS—10 db to +18 db, +10 db to +38 db, +30 db to +58 db. All based on 0 db = .006 watts (6 mw) into a 500 ohm line (1.73v).
- ZERO CENTER METER—For discriminator alignment with full scale range of 0 to 1.5/7.5/37.5/75/150/375/750 volts at 11 megohms input resistance.

Model 77 comes complete with operating instructions, probe and test leads and carrying case. Price is \$42.50. Terms: \$12.50 after 10 day trial then \$6.00 monthly for 5 months.

SUPERIOR'S NEW MODEL 80

20,000 OHMS PER VOLT ALLMETER

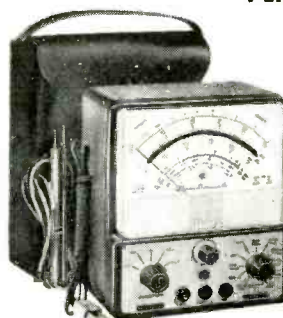

6 INCH FULL-VIEW METER provides large easy-to-read calibrations. No squinting or guessing when you use Model 80.

MIRRORED SCALE permits fine accurate measurements where fractional readings are important.

SPECIFICATIONS:

- 7 D.C. VOLTAGE RANGES: (At a sensitivity of 20,000 Ohms per Volt) 0 to 15/75/150/300/750/1500/7500 Volts.
- 6 A.C. VOLTAGE RANGES: (At a sensitivity of 5,000 Ohms per Volt) 0 to 15/75/150/300/750/1500 Volts.
- 3 RESISTANCE RANGES: 0 to 2,000/200,000 Ohms. 0-20 Megohms.
- 2 CAPACITY RANGES: .00025 Mfd. to 3 Mfd., .05 Mfd. to 30 Mfd.
- 5 D.C. CURRENT RANGES: 0-75 Microamperes. 0 to 7.5/75/750 Milli-amperes. 0 to 15 Amperes.
- 3 DECIBEL RANGES: -6 db to +18 db, +14 db to +38 db, +34 db to +58 db.

NOTE: The line cord is used only for capacity measurements. Resistance ranges operate on self-contained batteries.

Model 80 Allmeter comes complete with operating instructions, test leads and portable carrying case. Price is \$42.50. Terms: \$12.50 after 10 day trial then \$6.00 monthly for 5 months.

SUPERIOR'S NEW MODEL 70 UTILITY TESTER

FOR REPAIRING ALL ELECTRICAL APPLIANCES MOTORS * AUTOMOBILES



UTILITY TESTER INCLUDED FREE

64 page condensed course in electricity. Profusely illustrated. Written in simple, easy-to-understand style.

As an electrical trouble shooter the Model 70:

- Will test Toasters, Irons, Broilers, Heating Pads, Clocks, Fans, Vacuum Cleaners, Refrigerators, Lamps, Fluorescents, Switches, Thermostats, etc.
- Measures A.C. and D.C. Voltages, A.C. and D.C. Current, Resistances, Leakage, etc.
- Incorporates a sensitive direct-reading resistance range which will measure all resistances commonly used in electrical appliances, motors, etc.
- Leakage detecting circuit will indicate continuity from zero ohms to 5 megohms (5,000,000 ohms).

As an Automotive Tester the Model 70 will test:

- Both 6 Volt and 12 Volt Storage Batteries • Generators • Starters • Distributors • Ignition Coils
- Regulators • Relays • Circuit Breakers • Cigarette Lighters • Stop Lights • Condensers • Directional Signal Systems • All Lamps and Bulbs • Fuses • Heating Systems • Horns • Also will locate poor grounds, breaks in wiring, poor connections, etc.

Model 70 comes complete with 64 page book and test leads. Price is \$15.85. Terms: \$3.85 after 10 day trial then \$4.00 monthly for 3 months.

DID YOU EVER?

- ▶ Order merchandise by mail, including deposit or payment in full, then wait and write... wait and write?
- ▶ Purchase anything on time and sign a lengthy complex contract written in small difficult-to-read type?
- ▶ Purchase an item by mail or in a retail store then experience frustrating delay and red tape when you applied for a refund?

Obviously prompt shipment and attention to orders is an essential requirement in our business... We ship at our risk!

NO

CONTRACT TO SIGN

CO-MAKERS

**EMPLOYER
NOTIFICATION**

The simple order authorization included in this offer is all you sign. We ask only that you promise to pay for or return the goods we ship in good faith.

**EXAMINE ANY ITEM YOU SELECT
IN THE PRIVACY OF YOUR OWN HOME**

Then if completely satisfied pay on the interest-free terms plainly specified. When we say interest-free we mean not one penny added for "interest" for "finance" for "credit-checking" or for "carrying charges." The net price of each tester is plainly marked in our ads—that is all you pay except for parcel post or other transportation charges we may prepay.

SUPERIOR'S NEW MODEL 82A

MULTI-SOCKET TYPE

TUBE TESTER

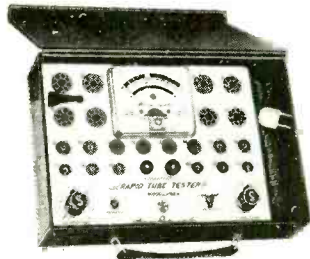

SPECIFICATIONS:

- Tests over 1000 tube types.
- Tests OZ4 and other gas-filled tubes.
- Employs new 4" meter with sealed air-damping chamber resulting in accurate vibrationless readings.
- Use of 22 sockets permits testing all popular tube types and prevents possible obsolescence.
- Dual Scale meter permits testing of low current tubes.
- 7 and 9 pin straighteners mounted on panel.
- All sections of multi-element tubes tested simultaneously.
- Ultra-sensitive leakage test circuit will indicate leakage up to 5 megohms.

Model 82A comes housed in handsome, portable, saddle-stitched Texon case. Price is \$36.50. Terms: \$6.50 after 10 day trial then \$6.00 monthly for 5 months.

SUPERIOR'S NEW MODEL TW-11

STANDARD PROFESSIONAL

TUBE TESTER

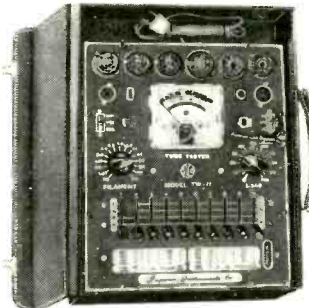

- Uses the new self-cleaning Lever Action Switches for individual element testing. Because all elements are numbered according to pin-number in the RMA base numbering system, the user can instantly identify which element is under test.
- Free-moving built-in roll chart provides complete data for all tubes. All tube listings printed in large-easy-to-read type.
- **NOISE TEST:** Phono-jack on front panel for plugging in either phones or external amplifier will detect microphonic tubes or noise due to faulty elements and loose internal connections.
- **SEPARATE SCALE FOR LOW-CURRENT TUBES**—Previously, on emission type tube testers, it has been standard practice to use one scale for all tubes. As a result, the calibration for low-current types has been restricted to a small portion of the scale. The extra scale used here greatly simplifies testing of low-current types.

The Model TW-11 comes housed in a handsome, portable, saddle-stitched Texon case. Price is \$47.50. Terms: \$11.50 after 10 day trial then \$6.00 monthly for 6 months.

SUPERIOR'S NEW MODEL 83A

C.R.T. TESTER

Tests and Rejuvenates

ALL PICTURE TUBES

ALL BLACK AND WHITE TUBES
From 50 degree to 110 degree types—
from 8" to 30" types.

ALL COLOR TUBES
Test ALL picture tubes—in the carton
—out of the carton—in the set!

Model 83A provides separate filament operating voltages for the older 6.3 types and the newer 8.4 types.

Model 83A properly tests the red, green and blue sections of color tubes individually—for each section of a color tube contains its own filament, plate, grid and cathode. Model 83A will detect tubes which are apparently good but require rejuvenation. Such tubes will provide a picture seemingly good but lacking in proper definition, contrast and focus.

Rejuvenation of picture tubes is not simply a matter of applying a high voltage to the filament. Such voltages improperly applied can strip the cathode of the oxide coating essential for proper emission. The Model 83A applies a selective low voltage uniformly to assure increased life with no danger of cathode damage.

Model 83-A comes housed in handsome portable Saddle-stitched Texon case—complete with socket for all black and white tubes and all color tubes. Price is \$38.50. Terms: \$8.50 after 10 day trial then \$6.00 monthly for 5 months.

SUPERIOR'S NEW MODEL TV-50A

GENOMETER

7 Signal Generators in One!



- ✓ R.F. Signal Generator for A.M.
- ✓ R.F. Signal Generator for F.M.
- ✓ Audio Frequency Generator
- ✓ Bar Generator
- ✓ Cross Hatch Generator
- ✓ Color Dot Pattern Generator
- ✓ Marker Generator

A versatile all-inclusive GENERATOR which provides ALL the outputs for servicing:

A.M. Radio • F.M. Radio • Amplifiers
• Black and White TV • Color TV

The Model TV-50A comes absolutely complete with shielded leads and operating instructions. Price is \$47.50. Terms: \$11.50 after 10 day trial then \$6.00 monthly for 6 months.

SUPERIOR'S NEW MODEL 85

TRANS-CONDUCTANCE TYPE TUBE TESTER

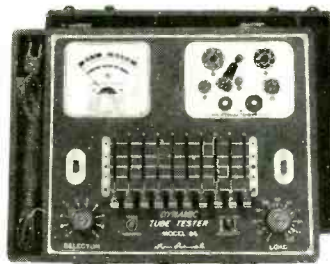

- Employs latest improved TRANS-CONDUCTANCE circuit. Test tubes under "dynamic" (simulated) operating conditions. An in-phase signal is impressed on the input section of a tube and the resultant plate current change is measured as a function of tube quality. This provides the most suitable method of simulating the manner in which tubes actually operate in radio, TV receivers, amplifiers and other circuits. Amplification factor, plate resistance and cathode emission are all correlated in one meter reading.
- **SYMBOL REFERENCES:** Model 85 employs time-saving symbols (A, B, C, D, E, F, G, H, I, J, K, L, M, N, O, P, Q, R, S, T, U, V, W, X, Y, Z) in place of difficult-to-remember letters previously used. Repeated time-studies proved to us that use of these scientifically selected symbols speeded up the element switching step. As the tube manufacturers increase the release of new tube types, this time-saving feature becomes necessary and advantageous.

Model 85 comes complete, housed in a handsome portable cabinet with slip-on cover. Price is \$52.50. Terms: \$12.50 after 10 day trial then \$8.00 monthly for 5 months.

• **FREE-POINT LEVER TYPE ELEMENT SWITCH ASSEMBLY** marked according to RETMA basing, permits application of test voltages to any of the elements of a tube.

• **FREE FIVE (5) YEAR CHART DATA SERVICE.** Revised up-to-date subsequent charts will be mailed to all Model 85 purchasers at no charge for a period of five years after date of purchase.

Model 85 comes complete, housed in a handsome portable cabinet with slip-on cover. Price is \$52.50. Terms: \$12.50 after 10 day trial then \$8.00 monthly for 5 months.

SUPERIOR'S NEW MODEL 88

TESTS ALL TRANSISTORS AND TRANSISTOR RADIOS



AS A TRANSISTOR RADIO TESTER

An R.F. Signal source, modulated by an audio tone is injected into the transistor receiver from the antenna through the R.F. stage, past the mixer into the I.F. Amplifier and detector stages and on to the audio amplifier. This injected signal is then followed and traced through the receiver by means of a built-in High Gain Transistorized Signal Tracer until the cause of trouble is located and pinpointed.

AS A TRANSISTOR TESTER

The Model 88 will test all transistors including NPN and PNP, silicon, germanium and the new gallium arsenide types, without referring to characteristic data sheets. The time-saving advantage of this technique is self-evident. A further benefit of this service is that it will enable you to test new transistors as they are released!

Model 88 comes housed in a handsome portable case. Complete with a set of Clip-on Cables for Transistor Testing; an R.F. Diode Probe for R.F. & I.F. Testing; an Audio Probe for Amplifier Tracing and a Signal Injector Cable. Complete—nothing else to buy! Price is \$38.50. Terms: \$8.50 after 10 day trial then \$6.00 monthly for 5 months.

Try any of the instruments on this or the facing page for 10 days before you buy. If completely satisfied then send down payment and pay balance as indicated on coupon. No interest or Finance Charges Added! If not completely satisfied return unit to us, no explanation necessary.

MOSS ELECTRONIC, INC., Dept. D-846, 3849 Tenth Ave., New York 34, N. Y.

Please send me the units checked on approval. If completely satisfied I will pay on the terms specified with no interest or finance charges added. Otherwise, I will return after a 10 day trial positively cancelling all further obligations.

- | | | |
|----------------------------------------------------------------------------------------------------------------------|---------------------------------------------------------------------------------------------------------------------|------------------------------------------------------------------------------------------------------------------------|
| <input type="checkbox"/> Model 770-A Total Price \$15.85 \$3.85 within 10 days. Balance \$4.00 monthly for 3 months. | <input type="checkbox"/> Model 83-A Total Price \$38.50 \$8.50 within 10 days. Balance \$6.00 monthly for 5 months. | <input type="checkbox"/> Model 85 Total Price \$52.50 \$12.50 within 10 days. Balance \$8.00 monthly for 5 months. |
| <input type="checkbox"/> Model 79 Total Price \$38.50 \$8.50 within 10 days. Balance \$6.00 monthly for 5 months. | <input type="checkbox"/> Model 70 Total Price \$15.85 \$3.85 within 10 days. Balance \$4.00 monthly for 3 months. | <input type="checkbox"/> Model TV-50A Total Price \$47.50 \$11.50 within 10 days. Balance \$6.00 monthly for 6 months. |
| <input type="checkbox"/> Model 77 Total Price \$42.50 \$12.50 within 10 days. Balance \$6.00 monthly for 5 months. | <input type="checkbox"/> Model 82-A Total Price \$36.50 \$6.50 within 10 days. Balance \$6.00 monthly for 5 months. | <input type="checkbox"/> Model 88 Total Price \$38.50 \$8.50 within 10 days. Balance \$6.00 monthly for 5 months. |
| <input type="checkbox"/> Model 80 Total Price \$42.50 \$12.50 within 10 days. Balance \$6.00 monthly for 5 months. | <input type="checkbox"/> Model TW-11 Total Price \$47.50 | |

Name

Address

City Zone State

All prices net. F.O.B. N.Y.C.

Export Division: **Rocke International Corp.**
13 East 40th St., New York 16, N.Y.

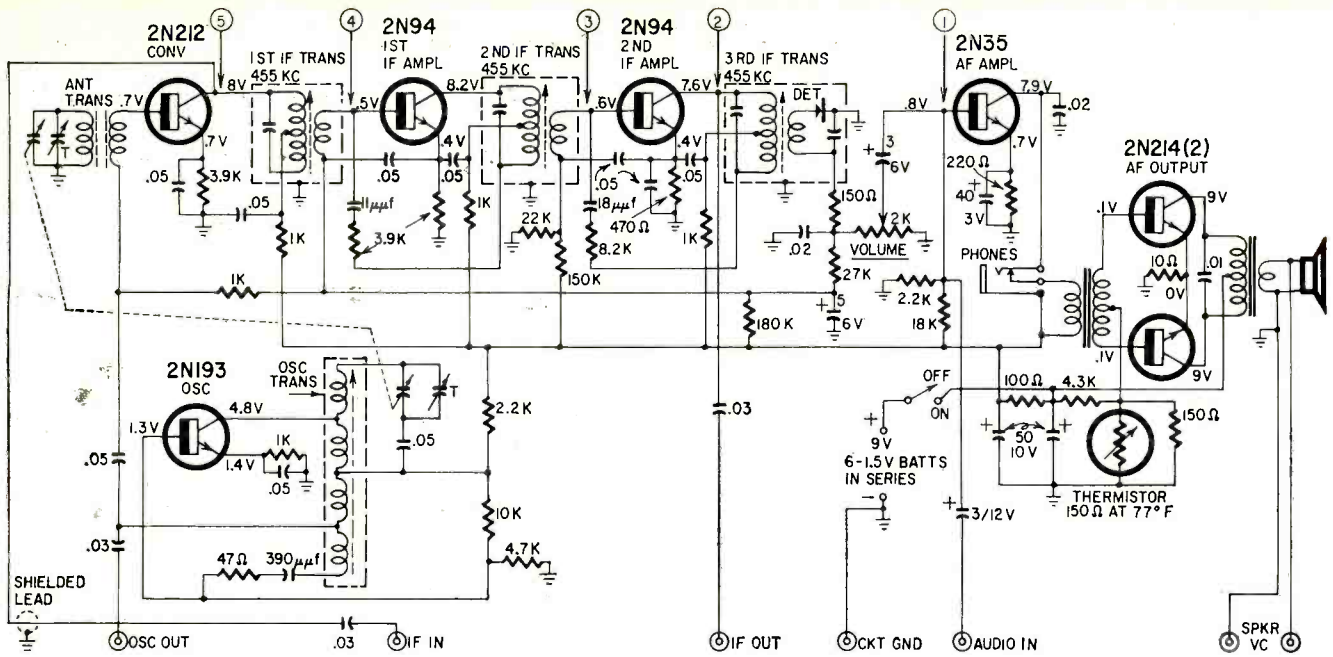

Fig. 1—The substitution checker is a good transistor receiver, with jacks brought out as indicated.

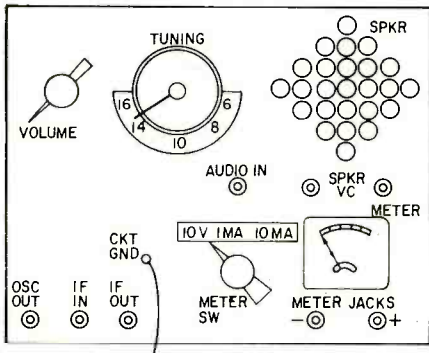

Fig. 2—Suggested front-panel layout for checker, including a meter.

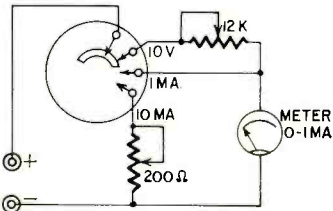

Fig. 3—Circuit for the meter, if used.

(Continued from page 85)

will use Fig. 1 again, this time to indicate the set being serviced. The test points indicated by circled numbers 1 through 5 along the top of the schematic will indicate connections made into the inoperative set.

Starting with the output section of our receiver, we can check the speaker voice coil by taking the output from SPKR VC and feed it directly to the speaker terminals. The SPKR VC jacks have another good use. If we wish to use the audio section of our substitution checker to service the audio section in the radio, we can short across the voice coil jacks and eliminate the sound from the checker. *Do not open the voice-coil circuit of a transistor radio.* The output transistors and circuit components can be damaged if the load is removed from the output transformer and the radio operated.

A two-way check can be made in any one of the circuits. We can feed audio from the AUDIO IN jack to test point 1 of the inoperative set and listen to the results from either speaker by turning either set on and off station.

We can perform the same check by connecting test point 2 of the set we are repairing to the IF OUT jack. It provides an amplified 455-kc output that can be coupled to test points 3 and 4 to determine the operation of the if's in the set. A definite increase in the sound should be noted when feeding 455-kc to test points 2, 3 and 4.

At test point 4 we can make a sensitivity as well as circuit operating check on the converter circuit in the inoperative set. Connecting point 4 to the IF IN jack, we can feed the output of the converter circuit into our circuit analyzer and listen to the output. As we tune across the dial on the set we are checking, the output should be normal.

If only the oscillator section of the radio we are checking is defective, we can bring the set back to life by tuning

both sets to the same station and feeding the OSC OUT to test point 5.

Transistor fundamentals

For a brief review on transistor theory refer to Fig. 4. An n-p-n transistor is used for the example instead of the more common p-n-p, because the technician is more at home with the electron than with the "hole" (the little electron that isn't there). Substitute holes for electrons, and the discussion applies to p-n-p transistors.

In the transistor, the left section of the circuit is biased for maximum current (low resistance); the right side is connected for minimum current (high resistance).

Resistance in the emitter-to-base circuit could be about 500 ohms and in the collector-to-base about 500,000 ohms. The n-type germanium in the emitter section of the transistor contains a surplus of electrons. These surplus electrons are accelerated toward the base when the negative voltage is

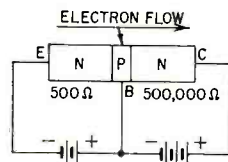
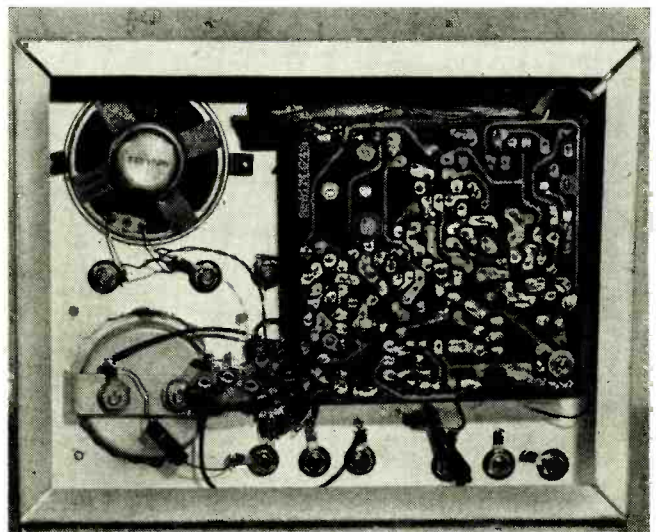

Fig. 4—Basic diagram, n-p-n transistor.



Inside view of the substitutor.

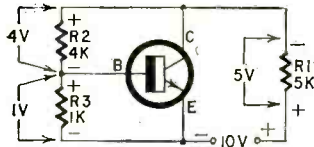

Fig. 5—A circuit using one battery.

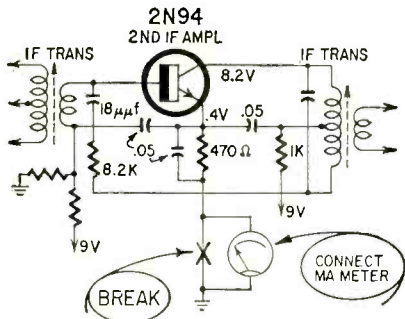

Fig. 6—How bias-current check is made.

applied to the emitter. The normal path for this current would be back to the positive terminal of the battery through the base connection. For several reasons—one that the base section is physically very thin, another that as soon as the electrons approach the base region they are attracted toward the collector because of the positive voltage applied to it—most of these electrons cross the base section and continue on to the collector.

If 100 electrons left the emitter area, approximately 95 of them would reach the collector, with only 5 returning through the base connection. Referring again to the resistance of the emitter and collector, we see that we have only a 5% current loss but a resistance gain of $500,000/500$ which gives us a voltage gain of $0.95 \times 500,000/500$, or 950. Before we can get this voltage gain, it is necessary to have bias current flowing in the emitter-to-base portion of the transistor.

Refer again to the bias applied in Fig. 4 and a common method of obtaining bias for a common-emitter amplifier shown in Fig. 5.

The highest positive potential is applied to the collector as in Fig. 5. Let us assume that we have 10 volts available from the battery and the bias bleeder is made up of: R1—5,000 ohms, R2—4,000 ohms, R3—1,000 ohms. Voltage drops across these resistors, without considering the internal resistance of the transistor, would be R1—5 volts, R2—4 volts and R3—1 volt. This places the collector 4 volts positive with respect to base, and the base 1 volt positive with respect to the emitter, and we have satisfied the bias needs with only one voltage source.

A typical example

To apply this current-check method of servicing, let us assume that we have injected a 455-kc signal from the IF OUT jack of our circuit checker into the collector and base of the if stage in Fig. 6. The results were the same with
(Continued on page 94)

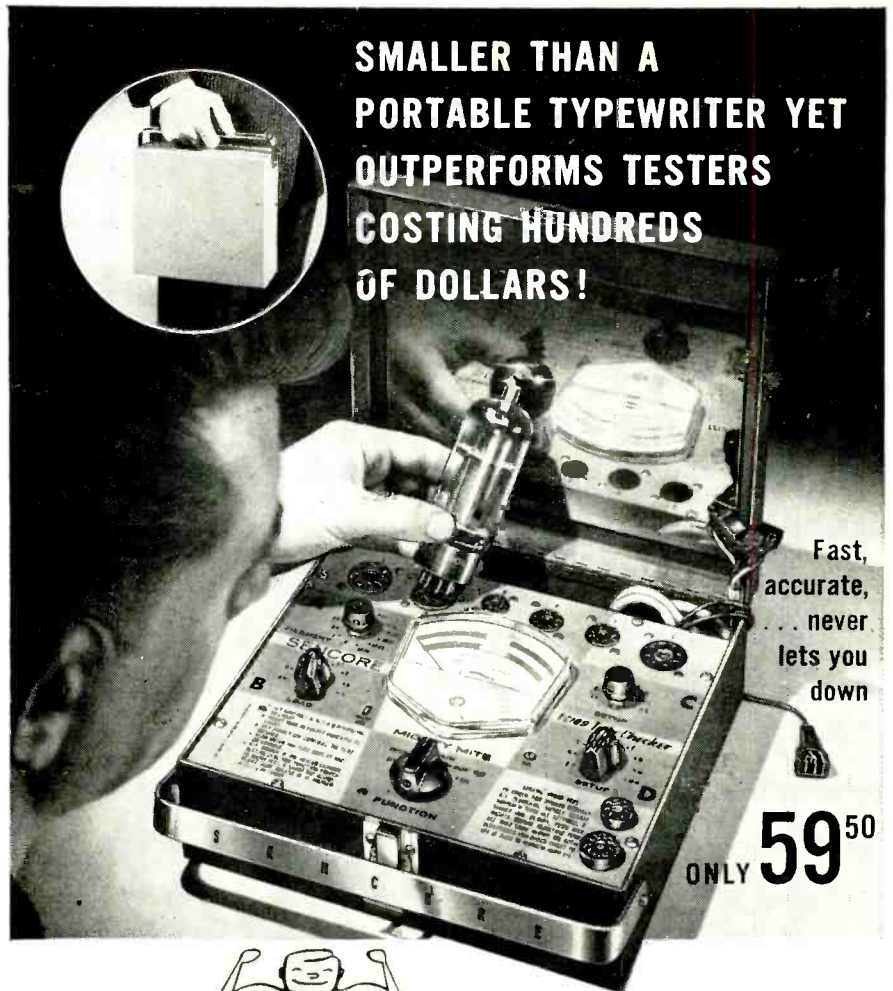

The MIGHTY MITE by SENCORE

The TC109 Tube Checker is a real money maker for the serviceman and a trusty companion for engineers, maintenance men and experimenters. Even students and hobbyists can afford the Mighty Mite for their own use or to service an occasional Radio or TV set. This small complete tester is a tremendous performer that spots bad tubes missed by costly mutual conductance testers.

New unique "stethoscope" approach tests for grid emission and leakage as high as 100 megohms, yet checks cathode current at operating levels. Special short test checks for shorts between all elements. The MIGHTY MITE will test every radio and TV tube that you encounter (over 1300!) plus picture tubes, foreign, five star and auto radio tubes (without damage). As easy to set up as a "speedy tester" from easy to follow tube booklet. New tube charts free of charge. Simple operating instructions are screened on the front panel.

Check these plus Sencore features • Meter glows in dark for easy reading behind TV set • Stainless steel mirror in cover for TV adjustment • Rugged, all steel carrying case and easy grip handle • Smallest complete tester made • Inner chassis can be easily transferred to tube caddy, bench or counter. • Only 9" x 8" x 2½". • Wt. 8 lbs.

See your
Distributor...
if he cannot help
you, Pat will



PAT RUDE,
Customer Service

SENCORE, ADDISON 3, ILLINOIS

Dear Pat: Will you please...

- Send me _____ Mighty Mite
 Check or M.O. enclosed (PP Prepaid.) Send C.O.D.

Distributor's Name (if any) _____

Your Name _____

Street _____

City _____ Zone _____ State _____

ALL UNITS FULLY GUARANTEED OR MONEY BACK WITHIN 10 DAYS

For the Man Who Wants an Advanced Home-Study Program in Electronic Engineering Technology or Nuclear Engineering Technology...

CREI opens the door to
HIGHER STATUS,
BETTER INCOME,
and a **SECURE**
FUTURE in the
forefront of
TECHNOLOGICAL
ADVANCEMENT



The world of science is the world of the future. There is no career more stimulating, challenging, or rewarding than that of working with topflight scientists and engineers to develop deep space probes and orbital satellite systems . . . package nuclear power reactors to provide economical, long-lasting power anywhere in the world . . . electronics and radioisotopes for use in medicine, agriculture and industry . . . missile systems for the Armed Forces . . . computers and data processing systems which

will become accepted necessities by finance, industry and government . . . to develop a thousand and one concepts that will make our world a better and safer place for all. You can have a career—or speed up your present career—in one or more of these areas if you are eligible to enroll in a CREI home-study program . . . a program recognized everywhere as excellent insurance for a secure future, high professional stature, and better income.

**Free 44-page book about
Electronics and CREI pro-
gram of study . . . gives you
facts on advancing your
career status—improving
your income**



— This is a Postage-Free POST CARD . . . Fill out . . .
detach . . . and mail today for YOUR FREE COPY

FIRST CLASS

PERMIT NO. 288-R

Washington, D. C.



BUSINESS REPLY MAIL

No Postage Stamp Necessary if Mailed in United States

Postage Will Be Paid By



3224 Sixteenth Street, N.W.

WASHINGTON 10, D. C.

1401H

Learn how the CREI program of home study can advance your career and income

Please provide all requested
data to help us evaluate
your qualifications
and your needs



SEND THIS POSTAGE-PAID CARD
FOR FREE 44-PAGE BOOK

THE CAPITOL RADIO ENGINEERING INSTITUTE

ECPD Accredited Technical Institute Curricula • Founded 1927

Dept. 3224 Sixteenth St., N. W., Washington 10, D. C.

Please send me your FREE BOOK "Insurance for Your Future
in the New World of Electronics" . . . describing oppor-
tunities and the CREI extension programs in Advanced
Electronic Engineering Technology.

- CHECK Servo and Computer Engineering Technology
FIELD OF Electronic Engineering Technology
GREATEST Communications Engineering Technology
INTEREST Aero and Navigational Engineering Technology
 Automation and Industrial Electronics Eng. Tech.
NEW Nuclear Engineering Technology

Name _____ Age _____

Street _____

City _____ Zone _____ State _____

Check: Home Study Residence Program GI Bill

TO OBTAIN FAST, IMMEDIATE SERVICE AND TO AVOID
DELAY, IT IS NECESSARY THAT THE FOLLOWING IN-
FORMATION BE FILLED IN:

EMPLOYED BY _____

TYPE OF PRESENT WORK _____

EDUCATION: YEARS HIGH SCHOOL _____ OTHER _____

ELECTRONICS EXPERIENCE _____

CREI's Extension Division now offers you college-level programs combining the technological content of advanced residence courses with convenience and economy of home study.

The quality of a CREI education may be gauged by the fact that the demand for CREI graduates and students at the CREI Placement Bureau has far exceeded the supply for several years. Many leading companies and Government agencies send representatives to CREI every year to hire graduates and students for their technical staff. The CREI educational programs were developed in conjunction with leading industrial concerns and government agencies directly interested in the nation's scientific and technological future.

There are now more than 20,000 CREI students in all the 50 states and most countries of the free world. You, too, can follow your CREI program while you remain in your present job. You study at home, when and as you choose . . . and you avoid the time and expense of commuting to a residence school. Within two to four years, depending upon the courses you select and the time you have to apply, you can complete a CREI program in engineering technology. The courses are written in easy-to-understand format, and your personal progress is carefully guided by CREI's competent faculty.

CREI programs bring you the latest technical advances and breakthroughs.

Recent advances and new techniques have placed great importance on how modern and up-to-date the individual's education is. Recognizing this, CREI maintains a large staff of engineers, educators and scientists who occupy prominent positions in government and industry. These men continuously revise the CREI courses and incorporate all new technical information. CREI courses are the most modern you will find . . . anywhere.

The CREI program is designed to meet your present and future employment needs and to increase your professional status and earning power.

CREI students frequently gain promotions and increases in pay long *before* they complete the program. As a graduate you will find that you gain stature and respect among your professional colleagues and supervisors, and

NEW 56-Page Catalog Gives Important Facts About Electronics, Nucleonics . . . and CREI. Send Post-Paid Card Attached For Your Free Copy.

Just published to include new courses being offered by CREI, this informative catalogue discusses the electronic and nuclear industries and answers searching questions about future manpower requirements and career opportunities. The catalogue describes all the courses, the alternative programs . . . it introduces the faculty who will be carefully guiding your progress . . . and it points

that you enjoy a personal satisfaction that comes from working and communicating intelligently with your associates. CREI graduates are important members of the engineering team. Your employer will recognize the assets of your up-to-date education . . . to your personal advantage.

Officials of private industry and government approve CREI for their own personnel.

The National Broadcasting Company . . . Radio Corporation of America . . . Pan American Airways . . . The Martin Company . . . Canadair Limited . . . Canadian Marconi . . . the Voice of America . . . the British Air Force, Navy and Army . . . and some 50 other electronic and nuclear organizations actually *pay all or a substantial part of the tuition* for employees taking a CREI home-study program. Right now, there are 5,240 U. S. Navy personnel enrolled in the CREI extension program.

Official accreditation and recognition.

Founded in 1927, CREI is one of the oldest technical institutes in America. CREI co-founded the National Council of Technical Schools, and was one of the first three institutes whose curricula was accredited by the Engineer's Council for Professional Development. The U. S. Office of Education lists CREI as an "institution of higher learning."

CREI conducts a residence school

in Washington, D. C., for those who wish to attend classes. The regular program of 27 months leads to an AAS degree. No previous technical experience or training is necessary for the residence school.

Qualifications for enrollment.

You qualify for CREI enrollment if you have a high school diploma or equivalent, and if you have had basic technical training or practical experience. Send for free catalogue for details. Tuition is reasonable, and veterans can take advantage of the G.I. Bill.

ECPD ACCREDITED TECHNICAL INSTITUTE CURRICULA • FOUNDED 1927

The Capitol Radio Engineering Institute



Home Office:
3224 16TH STREET, N.W.,
WASHINGTON 10, D.C., U.S.A.,
Dept. 1401-H

England:
CREI LONDON, GRANVILLE HOUSE,
132-135 SLOANE STREET, LONDON,
S.W. 1, ENGLAND

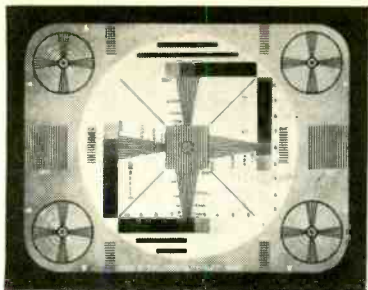

TV TIPS FROM TRIAD

"What gives with the schnorkel?," asked Bill as he examined the receiver on the bench. A four inch line of vent tubing angled up crazily and appeared to originate in the lower portion of the cabinet. A slight whirring sound suggested some kind of motor operating in the nether recesses.

"You are looking at the second power transformer I've installed in that set," answered Joe. "With everything normal it still smells after running for a couple of hours with the cabinet buttoned up. I thought the little fan on the phono motor might move enough air if I had the vent to direct it out of the cabinet. Well, it seems to help, but I can't put the back on, and you can hear the motor when the room is quiet. Looks like I need a power transformer that will give more watts without being one iota larger."

Neither Bill nor Joe had noticed Al, the parts salesman, enter, which was unusual, because Al was usually very noticeable, and today he was still exhibiting effects of the weekly sales meeting brainwashing.

"Just happen to have exactly what you want," said Al, "I looked over the shipment of new Triad power transformers with Triple X Steel," —he shifted smoothly into high gear—"and these transformers use the same size iron, so they fit, but because they're made of fine grade audio steel, we can design them to operate at a higher flux density and in many cases do not need heat dissipating fins to maintain safe temperatures—"

"Send me one," said Joe.

"—and since the efficiency of the steel is higher we do not require as large a stack, so our copper losses are lower—"

"I'm sold," said Joe.

"—and by utilizing a simple type of mounting bracket you can adapt the new series, even where the original had an unusual configuration —Oh, you'll take one? So soon? What's the matter? Don't want to learn anything?"

* * *

MORAL: Sometimes a little "extra" in a replacement part will help make up for the effects of ageing in the receivers you service. If you would like to see for yourself how "Triple X" differs from the old "one grade better than stovepipe iron" drop us a line and we will be pleased to send you a sample. We will also include information on the new "Triple X" units. Write to **Triad Transformer Corporation**, 4055 Redwood Ave., Venice, California.

(Continued from page 89)

the signal applied to the base or collector, indicating no gain through the transistor. The first check would be to measure the voltage on the collector.

The next step would be to determine the correct bias on the transistor. The schematic indicates 0.4-volt bias at the emitter. This voltage is developed across the bias resistor (470 ohms) so that the bias current must be 0.4/470, almost 1 ma. A bias current check is always more accurate than a voltage check.

With the meter still connected, we can also check for leakage in the transistor by shorting the unit's emitter to its base. If the current does not drop to almost zero, we can be sure the transistor has internal leakage. This check is important in miniature radios where current must be kept at a minimum to insure long battery life.

Bias current is also important in checking the push-pull output circuit. We can easily determine if the output transistors are matched by breaking the emitter connection on each transistor and checking to see if the current in each emitter is approximately equal.

To match transistors in a push-pull circuit, note the emitter bias current in one transistor and substitute transistors in the opposite socket until equal bias current is obtained.

If the radio has solder-in transistors, solder a socket in place temporarily when trying new transistors. Your stock of new transistors will remain in good condition if you avoid soldering them in for testing. END

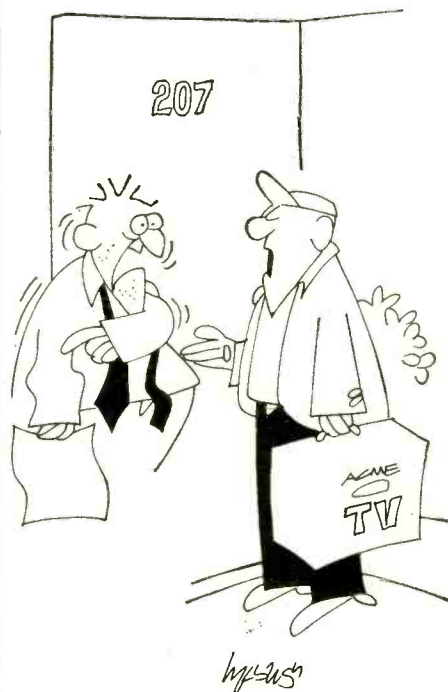

"Take this tranquilizer and lie down and relax. I'll try to get your set fixed in time for you to see 'Gunsmoke'."



**Model 300
COMBINATION TESTER**

A complete portable service shop at your side wherever you go

Housed in handsome wood carrying case.

Model 300 \$99.75 Net

3 ESSENTIAL INSTRUMENTS IN ONE COMPACT UNIT!

- 1 A multiple socket tube tester
- 2 A CRT tester-reactivator
- 3 A 20,000 ohms per volt VOM and capacity tester

AS A TUBE TESTER . . . will check emission, inter-element leakage and gas content of all tubes.

AS A CRT TESTER-REACTIVATOR . . . will test, repair and reactivate all black and white and all color picture tubes.

AS A VOM AND CAPACITY TESTER
(20,000 ohms/volt)
DC Voltage: 0 to 7500 volts
AC Voltage: 0 to 1500 volts
Ohms: 0 to 10 megohms
DC Current: 0 to 15 amperes
Capacity: .1 mfd. to 180 mfd.

Handy mirror in cover for TV adjustments

See your electronics parts distributor!



MERCURY ELECTRONICS CORP. 77 SEARING AVENUE, MINEOLA, NEW YORK

SINGLE-CURVE CHART

By E. T. THIERSCH

THIS chart solves parallel resistor inductor, (provided their magnetic fields do not interact) and series capacitor problems. Both scales are in percentages of component one (R1, C1 or L1, see chart). The horizontal scale gives component 2's percentage of component 1; the vertical scale gives resultant or total R, C or L.

Example: Determine total R of a 200-ohm resistor (R1) and an 800-ohm resistor (R2) in parallel. Since 800 is

400% of 200, follow the 400 line from the bottom of the chart until it hits the curve. From there go to the left and read the answer as 80% of R1, or 160 ohms.

Another example: What capacitance (C2) is needed in series with a 500- μf capacitor (C1) to make a total of 300 μf . Since 300 is 60% of 500, go to the right from 60, down from the intersection and read the answer as 150. C2 should be 150% of C1, or 750 μf . END

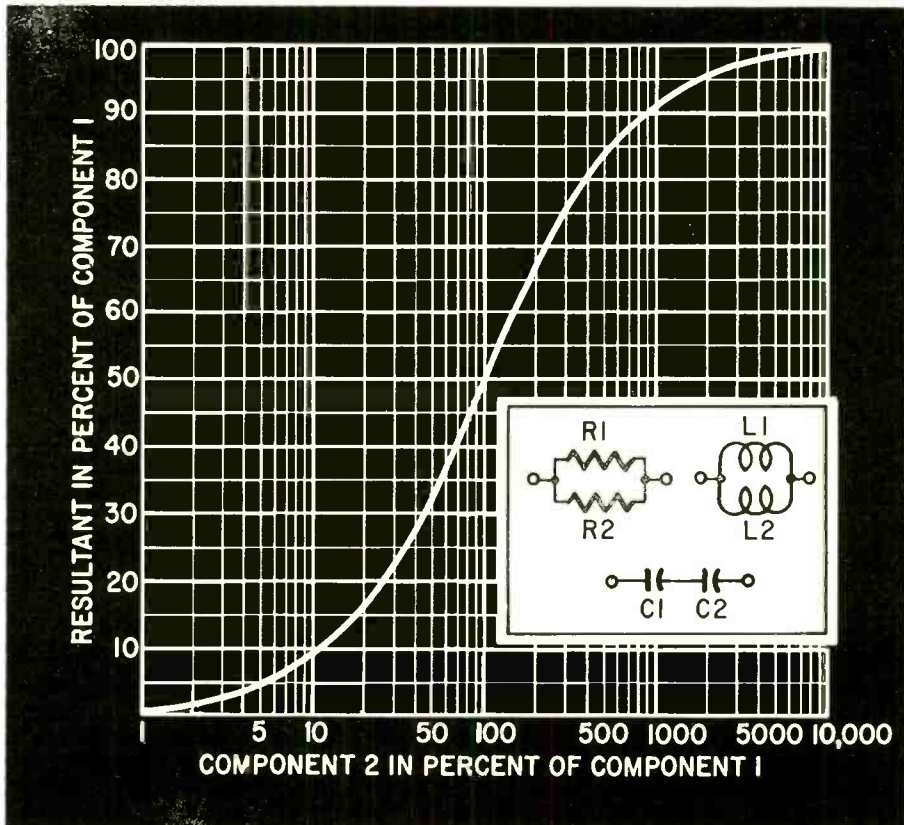

how often
could you
have used...

an
Xcelite
"Seizer"?

Handy as an extra
hand or helper.
Clamps lightly
or tightly ... for
moments or minutes.

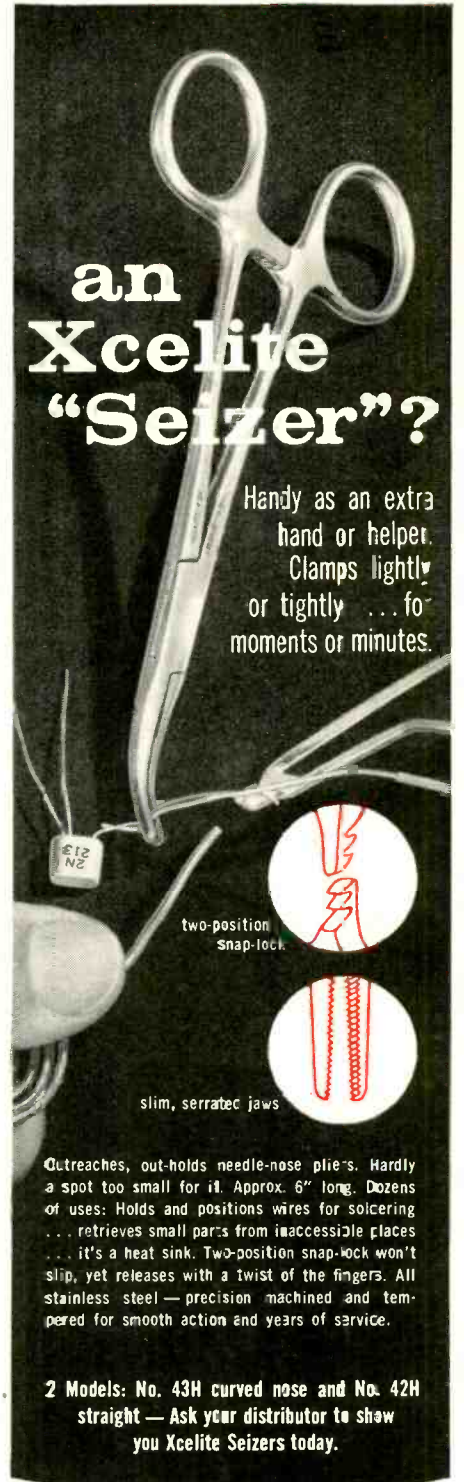

Outreaches, out-holds needle-nose pliers. Hardly a spot too small for it. Approx. 6" long. Dozens of uses: Holds and positions wires for soldering ... retrieves small parts from inaccessible places ... it's a heat sink. Two-position snap-lock won't slip, yet releases with a twist of the fingers. All stainless steel — precision machined and tempered for smooth action and years of service.

2 Models: No. 43H curved nose and No. 42H straight — Ask your distributor to show you Xcelite Seizers today.

XCELITE

XCELITE, INC. • ORCHARD PARK, N. Y.
Canada: Charles W. Pointon, Ltd., Toronto, Ont.

new PRODUCTS

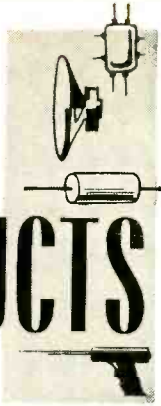

INDOOR TV ANTENNA, Slim-Line, models A6M and A6B. For black-and-white and color TV and FM reception.



Blond and mahogany finishes.—Clear Beam Antenna Corp., Canoga Park, Calif.

TRANSISTORIZED DEPTH FINDER, model DF-90, kit or factory wired. Operates from boat's power source or batteries. Oversize reading scale cali-



brated in 1-foot intervals with 0-120-foot range. Barium titanite hermetically sealed transducer. Gymbal mount can be used as carrying handle. All-aluminum. 9 pounds. 7 x 5 3/4 x 6 inches.—PACO Electronics Co. Inc., 70-31 84 St., Glendale 27, N.Y.

TRANSCEIVER (120 watts CW), G-76. Covers 6 amateur bands, 3.5, 7, 14, 21 and 28 and 50 mc. 1 foot wide, 6 inches high. Fits under dash of vehicle



in mobile applications. 117-volt ac power supply including loudspeaker; transistor 12-volt dc supply for mobile applications.—Gonset Div., Young Spring & Wire Corp., 801 S. Main St., Burbank, Calif.

CW TRANSMITTER, model 723. Kit or factory wired and tested. 60 watts. 1-knob bandswitch covering 80, 40, 20, 15 and 10 meters. 1-knob off-standby-tune, transmit switch. Panel meter switches into grid or plate circuit of final. Modulator accessory socket for



modulator and emergency power input, antenna relay, vfo power takeoff. Copper-plated chassis. 6 x 8 1/2 x 9 inches.—EICO (Electronic Instrument Co. Inc.), 33-00 Northern Blvd., Long Island City 1, N. Y.

CALIBRATION STANDARD, model 381, professional. For recording channel



calibration, radio stations and record evaluation. High-impedance model, 47,000-100,000 ohms. Low-impedance, 250 or 500/600 ohms. Response flat within 1 db from 20 to 10,000 cycles; within 2 db from 10 kc to 17 kc. 5-mv output per channel. 35-db channel separation.—Pickering & Co. Inc., Sunnyside Blvd., Plainview, New York.

ADD-ON REVERB UNIT, RVB-1. Monaural or stereo. Complete with am-



plifier and speaker. Connects to speaker line. Interconnecting cables. Acoustic-control knob. 20 x 10 x 10 1/4 inches.—Utah Radio & Electronic Corp., 1124 E. Franklin St., Huntington, Ind.

REVERBERATION UNIT, KN-701. Short time delay in audio signal simu-

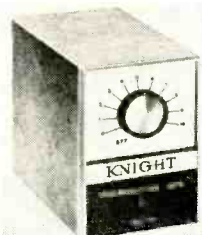

lates cathedral or stadium acoustics. Plugs into hi-fi system using separate preamp and amplifier.—Allied Radio Corp., 100 N. Western Ave., Chicago 80, Ill.

FM TUNER KIT, KT-650. Variable afc control. Electronic bar tuning indi-



cator tube. Flywheel weighted tuning. Front-panel tuner level control. Factory prealigned. Printed-circuit boards. Sensitivity; 2- μ v for 30-db quieting. Frequency response: $\pm 1/2$ db from 15 to 35,000 cycles. 14 x 5 1/2 x 11 inches.—Lafayette Radio Electronics Corp., 165-08 Liberty Ave., Jamaica 33, N. Y.

MICROPHONE, model CM-17 Flex-Mike. Ceramic transducer cushion-mounted in rubber. Feeds from 50 to over 11,000 cycles at -56-db sensitivity. Controlled presence peak in mid-range. One-piece, die-cast metal mike case on

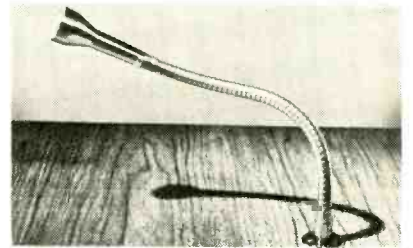

13-inch flexible stand terminating in removable mounting plate. Shielded electrical cable.—Sonotone Corp., Elmsford, N. Y.

PATIO SPEAKER, CA-60-P. Two 6-inch woofers. Cone type tweeter with built-in crossover. Frequency response: 70 to 17,000 cycles. Built-in carrying handle and 25-foot cable. Independent volume-control knob. Detachable legs. 9 x 10 x 18 inches.—Rek-O-Kut Co. Inc., 38-19 108th St., Corona 68, N. Y.

AMPLIFIER KIT, 72 watts, LK-72. IHFM power band extending down to 20

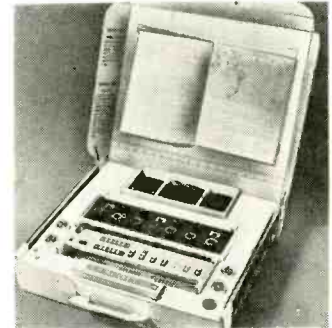

cycles. Less than 0.4% total harmonic distortion. Amplifier hum level better than 70-db below full power output. Four 7951 output tubes, two 7199's, four 12AX7's and a 5AR4. 12-pound transformers. 15 1/2 x 5 1/4 x 13 1/4 inches.—H. H. Scott Inc., Dept. P, 111 Powdermill Rd., Maynard, Mass.

80-WATT AMPLIFIER, Citation V. Kit and factory wired. 40 watts rms per channel with 95-watt peaks at less than 0.5% distortion. Rated power at extreme ends of frequency range. Two 7581's per channel, bias meter, 4 silicon diodes,

**RECOMMENDED
READING in**

Radio-Electronics FEBRUARY

Radio-Electronics

NEXT

MONTH

Do It With Diodes!

Never underestimate the power of the diode. You're missing plenty if you think this versatile and inexpensive little giant is nothing more than a rectifier or detector. Have you ever used it as a bi-lateral conductor, a switch, amplifier, voltage regulator? You can increase its applications immeasurably if you do. This article tells you how.

Build This In-Cabinet Horizontal Sweep Analyzer

How much time have you wasted and what pains have you gone to to get at the horizontal sweep circuit? Say goodbye to all that. This plug-in unit has many of the troubleshooting capabilities of specialized horizontal sweep test instruments. And it's fun to build.

Versatile SW Transistor Radio

Uses only 3 transistors—and it's a cinch to build. But look what it can do. Pulls in Citizens Band, 11-meter broadcast, and the 10-meter ham band. Add on a relay unit and it becomes a radio control or paging receiver.

Klystrons For Outer Space

New uses for a not so new type tube! This article tells how klystrons work and what they can do. Very worthwhile reading since klystrons are becoming more and more familiar as communications and industry move more and more towards microwaves—whether for satellite communications or short-range systems.

Plus many, many other top-flight features.

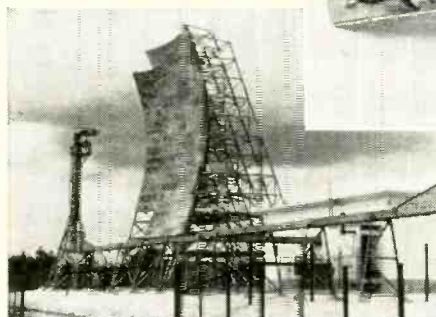
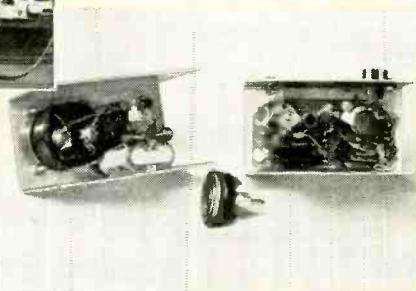
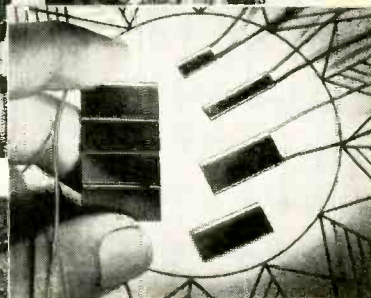
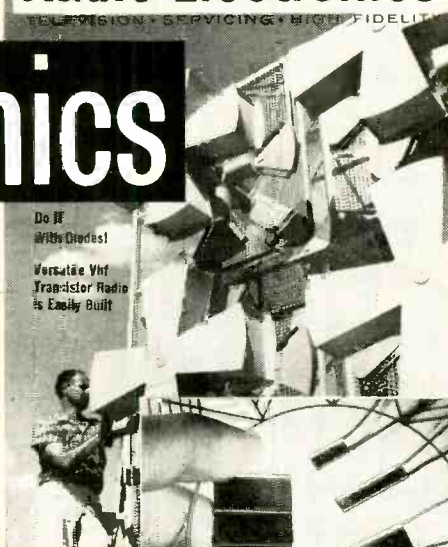

FEBRUARY ISSUE — ON SALE JANUARY 17

50 cents at newsstands and parts distributors

**RESERVE YOUR COPY NOW — or SAVE UP TO \$6.00 over
the newsstand price . SUBSCRIBE NOW**

3 years \$12

2 years \$9

1 year \$5

Radio-Electronics

154 West 14th Street, New York 11, N. Y.



heavy-duty electrolytics.—Harman-Kardon, Inc., Ames Court, Plainview, N. Y.

STEREO HEADSET, KN-840. Electrodynamic driver and hyperbolic baffle with 20-16,000-cycle frequency response

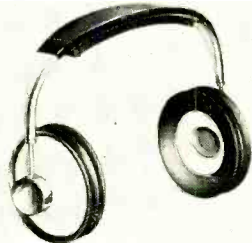

in each earphone. Designed to match low-impedance outputs.—Allied Radio Corp.—100 N. Western Ave., Chicago.

STEREO AMPLIFIER, AA-100 kit, WAA-100 wired. 25 watts per channel.



6 pairs of inputs, including provision for monophonic magnetic record cartridge. Mixed-channel speaker output.—Heath Co., Benton Harbor, Mich.

STEREO FM-AM TUNER, 202-R. 6 if stages. 0.5- μ v sensitivity for 20-db quieting with a 72-ohm antenna. Electronic switch muting functions during



multiplex operation. Wide-band design. 5 limiters for capture ratio of 1.5 db. 16 tubes, 4 diodes, rectifier. 90-watt power consumption. 15 $\frac{1}{8}$ x 4 13/16 x 12 $\frac{3}{4}$ inches.—Fisher Radio Corp., 21-21 44th Drive, Long Island City 1, N. Y.

STEREO AMPLIFIER 222B. 15 watts per channel. Tape monitoring facilities. Separate tone controls each



channel. Tape-head and electronic-organ inputs. Oversize 20-watt transformers. Aluminum chassis.—H. H. Scott, Inc., Dept. P, 111 Powdermill Rd., Maynard, Mass.

VACUUM TUBE VOLTMETER, model 850. Resistance ranges to 1,000

megohms. 0.5-volt low range on dc. 1,500-volt high range. Frequency range 15 cycles to 3 mc. Minimum ac imped-

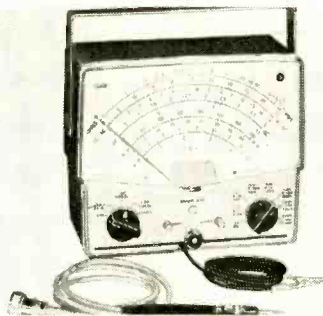

ance 0.83 megohm. 7 ac ranges cover 0 to 1,500 volts. Peak-to-peak ac to 4,000 volts.—Triplett Electrical Instrument Co., Harmon Road, Bluffton, Ohio.

IN-CIRCUIT RECTIFIER TESTER, model 600. Checks power rectifiers in



circuit for quality, shorts, fading, opens, arcing and life expectancy.—Mercury Electronics Corp., 77 Searing Ave., Mincola, N. Y.

TRANSISTOR ANALYZER, model 850-P. Measures transistor parameters in common-base, emitter and collector

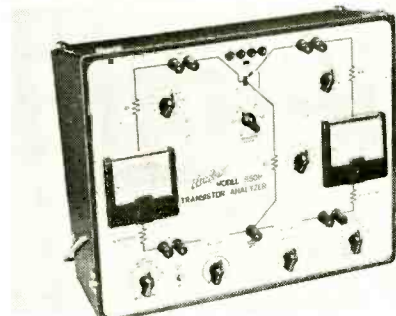

configurations. For n-p-n and p-n-p transistors. Circuit configuration in use shown on front panel.—Hickok Electrical Instrument Co., 10531 Dupont Ave., Cleveland 8, Ohio.

TELEVISION ANALYST, model 1076, pinpoints TV circuit troubles. Rf and if, video test pattern, composite sync, frequency-modulated audio, color patterns, horizontal and vertical plate drive, B-boost indicator and high-voltage transformer test signals on front panel. Includes switch type tuner, nega-



tive bias supply, age keying pulse and picture tube modulation.—B&K Manufacturing Co., 1801 W. Belle Plaine, Chicago 13, Ill.

TOOL HIP HOLSTER. Electric tape holder, knife clip and 5 tool pockets.



Natural cowhide.—Xcelite Inc., Orchard Park, N. Y.

ULTRA-MINIATURE JACK, TR-2A. 1/10th standard jack size. Accepts phone plugs for use on transistor radios and other miniaturized applications. 2-



conductor single-closed-circuit design but usable as open-circuit jack.—Switchcraft Inc., 5555 N. Elston Ave., Chicago 30, Ill.

TUNER-SHAFT ASSORTMENT, Multi-Fit. 18 shafts with wide replace-

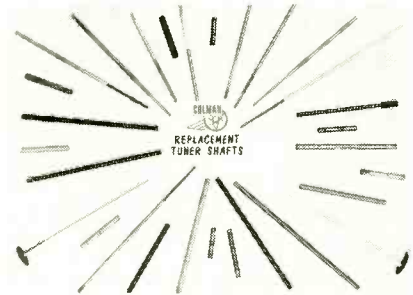

ment application. Fit most popular tuners.—Colman Electronic Products Inc., P.O. Box 2965, Amarillo, Tex.

REPLACEMENT TUNER PARTS. Kit model 31T3890 contains popular Standard Coil mechanical and electrical

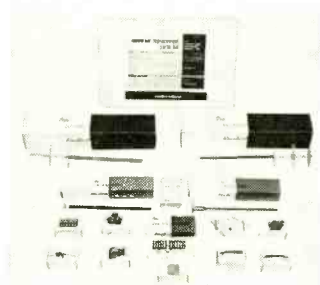

parts that include springs, detent and roller assemblies, if alignment tool and other parts for tuners manufactured between 1947 and 1957.—Standard Kollsman Industries Inc., Melrose Park, Ill.

PACKAGED ELECTRONIC CIRCUITS, PC-371 through PC-404. 3 vertical-integrator, 2 tone-control, 1 video- and 3 audio-coupling, phase-comparator, flip-flop, 2 yoke-balancing networks included.—Centralab, 900 E. Keefe Ave., Milwaukee 1, Wis. END

All specifications from manufacturers' data.

MAKE COMPLETE TUBE TEST FASTER, MORE ACCURATELY

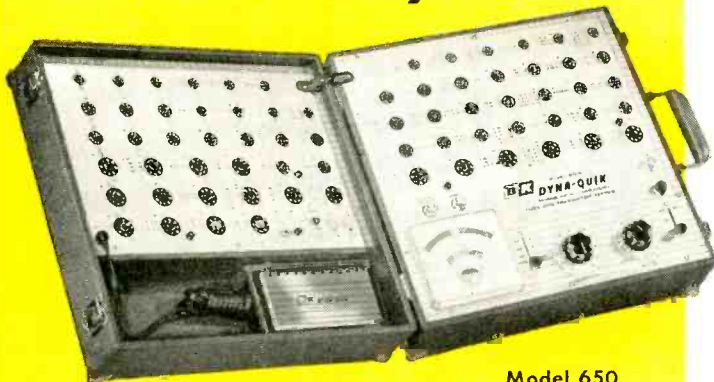

Model 650
DYNA-QUIK

Simply by checking all the tubes in the set, and testing each tube completely the Dynamic Mutual Conductance way, you can

**SELL MORE TUBES PER CALL
INCREASE YOUR INCOME*
SATISFY MORE CUSTOMERS
SAVE COSTLY CALL-BACKS
INSURE YOUR REPUTATION**

*Actual experience shows TV servicemen average 2 extra tube sales per call. 5 calls per day in 5 days means as much as \$50.00 more income per week.

Widely Used and Preferred by Thousands of Professional Servicemen Everywhere



Model 650 Dynamic Mutual Conductance PROFESSIONAL TUBE & TRANSISTOR TESTER

With multi-sockets and other B&K features, you can accurately quick-check most of the tubes widely used in television receivers, plus popular home and portable radio tubes. Includes spare sockets for new popular types. Tests each section of multiple tubes separately. Checks for Gm and all shorts. Makes highly sensitive grid emission and gas test. Checks for leakage and life. Shows true tube condition on "Good-Bad" scale and in micromhos. B&K patented bridge circuit. Also tests transistors.

Net, \$179⁹⁵

Model 550 Dynamic Mutual Conductance PROFESSIONAL TUBE TESTER

Real professional instrument for the limited budget. Provides 52 sockets to quick-check most of the TV and radio tubes usually encountered in everyday service work. Tests each section of dual-section tubes separately. Checks for Gm and all shorts. Makes highly sensitive grid emission, gas, and leakage test. Shows tube condition on "Good-Bad" scale and in micromhos. B&K patented bridge circuit.

Net, \$119⁹⁵



Model 550
DYNA-QUIK

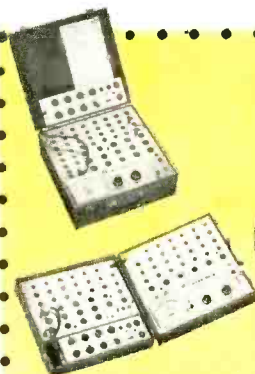

Shows how easily the new "610" fits into Models 550 and 650



Comes in 3 types:

Model 610-500 for use with Model 500 Tube Tester
Model 610-550 for use with Model 550 Tube Tester
Model 610-650 for use with Model 650 Tube Tester

NEW Model 610 ACCESSORY TEST PANEL

Increases Capacity of Model 500, 550, or 650 Dyna-Quik
TO TEST BOTH OLD AND NEW TUBE TYPES

including New TV Types, Thyratrons, Voltage Regulators, Auto Radio Hybrid Tubes, Battery Radio Tubes, European Hi-Fi Tubes, and most Industrial Types

Simply by adding Model 610 to the Dyna-Quik, you have all the advantages of fast multi-socket testing, plus freedom from obsolescence. Enables you to test all present plus future TV, radio, and other tube types. Measures genuine dynamic mutual conductance.

Net, \$49⁹⁵

NEW TUBE INFORMATION SERVICE

Get test data on new tubes even before you encounter them in the field. Subscribe now to *New Tube Information Service* for owners of B&K tube testers. Issued every 3 months, at \$2.50 per year.



B & K MANUFACTURING CO.
1801 W. BELLE PLAINE AVE • CHICAGO 13, ILL.
Canada: Atlas Radio Corp., 50 Wingold, Toronto 19, Ont.
Export: Empire Exporters, 277 Broadway, New York 7, U.S.A.

TECHNICIANS' ASSOCIATIONS

of the United States and Canada

THE following master list of electronic service technician's associations includes all such US and Canadian groups about which we have obtained information. Each listing has been checked and each group listed has been contacted to verify its address. We have attempted to list every asso-

ciation, but may have missed one or two along the way. Please let us know if your group has been left out.

Each state's listing is headed by Federations of service associations active in that state. The groups listed below do not necessarily belong to the federations listed above them, of course.

ARIZONA

Better Electronic Service Technicians
P. O. Box 1284
Phoenix
David Gordon,
Executive Secretary

Better Electronic Service Technicians of Tucson
4215 E. 22 St.
Tucson
Don Wallace, Secretary

ARKANSAS

Television Service Association of America
P. O. Box 542

North Little Rock
W. D. Todd, Secretary

CALIFORNIA

California State Electronics Association
1111 Weldon Ave.
Fresno 4
James F. Wakefield,
Executive Director

Long Beach
Fred S. Abrams, Jr.
San Fernando Valley Chapter, CSEA
7001 Reseda Blvd.
Reseda
E. A. Stevens, Secretary

Radio Technicians Association of California, Inc.
4729 E. Gage Ave.
Bell
Victor L. Bangle,
Executive Director

Riverside Chapter, CSEA, Inc.
P. O. Box 7074
Riverside
Ken Jenkins, Secretary

Bakersfield Chapter, RTA
P. O. Box 3245
Bakersfield
John L. Blackwood

Sacramento Chapter, CSEA
3093 Fair Oaks Blvd.
Sacramento
Keith Kirstein, Secretary

Los Cerritos CSEA-RTA
P. O. Box 129
Bellflower
H. J. Mackey, Secretary

Salinas RTDA
830 Park Row
Salinas
William Packwood,
Secretary

Glendale Burbank Chapter, CSEA
1617 W. Verdugo Ave.
Burbank
Ralph H. Johonnot,
President

San Bernardino Chapter, CSEA
P. O. Box 3398
San Bernardino
Victoria Garrison,
Secretary

San Francisco TVSA
36 Park Plaza
Daly City
J. Jerrold Strauss

San Diego CSEA
3331 El Cajon Blvd.
San Diego 4
Earl K. Robbins, Board of
Directors and Treasurer

Central Valley Chapter, RTA
4510 E. Balmont
Fresno
Louis E. Edises

Santa Clara Valley and Santa Cruz Chapter, CSEA
Rm. 467A, Porter Bldg.
San Jose 13
Chet Spink, Secretary

Glendale-Burbank Chapter, RTA
P. O. Box 4012
Glendale
Ralph H. Johonnot

Television and Electronic Association of Marin
1535 4th St.
San Rafael
Oakley Dexter, Secretary

South Bay RTA
2002 Springfield Ave.
Hermosa Beach
Lloyd Brown, President

Santa Monica CSEA
1642 Ocean Pk. Blvd.
Santa Monica
Harry Bernstein, Secretary

San Gabriel Valley Chapter, CSEA
P. O. Box 524
La Puente
Eddie McCoy, Secretary

Mother Lode Chapter, CSEA
167 Shepherd St.
Sonoma
Howard W. Nott,
Secretary

Long Beach RTA
1401 E. 55th St.

Independent TV Service Dealers Association of Los Angeles County, Inc.
213 S. Coronado St.
Los Angeles 57
Abe Bowers, Secretary

San Antonio Chapter, RTTA
P. O. Box 626
South Gate
Andrew Goodwin,
Secretary

Alameda County TV and Radio Association
5585 Thomas Ave.
Oakland 18
Fred W. Rock, Secretary

San Joaquin Chapter, CSEA
P. O. Box 1306
Stockton
Dave Young, Secretary

Pasadena Chapter, RTA
Main P. O. Box 1143
Pasadena
Bob Kealey, Secretary

San Joaquin RTA
2310 N. El Dorado
Stockton
Kenneth Preston

Pomona Valley Chapter, RTA
P. O. Box 567
Pomona

San Gabriel RTA
1200 Sylvan Ave.
West Covina
Jack F. Brown

CONNECTICUT

TELSA of Connecticut
P. O. Box 444
Meriden
Peter Lucus, President

Norwalk Chapter, TELSAs of Connecticut
Twin City Radio
N. Main St.
Norwalk
Peter Huntington,
President

Danbury Chapter, TELSAs of Connecticut
Main Radio & TV, Inc.,
272 Main St.
Danbury
Max Parcell, Secretary

Stratford Chapter, TELSAs of Connecticut
91 Huntington Rd.
Stratford
Robert Steer

TELSA of Meriden
7 Yale St.
Meriden
Bud Lackipo, President

Waterbury Chapter, TELSAs of Connecticut
P. O. Box 683
Waterbury
Bernard Fisherman,
Secretary

New Britain Chapter, TELSAs of Connecticut
c/o Ted's TV
Orange St.
New Britain
Ted Gryguk, Secretary

DELAWARE

TV Service Dealers Association of Delaware
808 W. 4th St.
Wilmington 1
James A. Mayhart, President

DISTRICT OF COLUMBIA

Television Service Association of Metropolitan Washington
Washington Bldg.
15th and York Ave. N. W.
Room 852
Washington, D. C.
Hyman Nussbaum, Executive Secretary

FLORIDA

Electronic Service Association of Broward County
901 N. W. 4th Ave.
Ft. Lauderdale
Hamilton Boyd, Secretary

Television Service Dealers Association of Greater St. Petersburg Area
121 108th Ave.
St. Petersburg
Arthur Oesterling,
Secretary

Television and Service Association of St. Lucie County
P. O. Box 381
Ft. Pierce
John Forget, Secretary

Tallahassee Television and Electronics Association
213 College Ave.
Tallahassee
Don Birch, Secretary

Jacksonville Electronics Technician Society
906 San Marco Blvd.
Jacksonville
Dale Andrews, President

Television Service Dealers Association of Palm Beach
407 Flamingo
W. Palm Beach
Roy Batton, President

TESA of Miami
6001 S. W. 20 St.
Miami
James J. Ross, Corresponding Secretary

TELEVISION ELECTRONIC ASSOCIATION OF MACON, INC.
P. O. Box 2033
Macon
James Moore, Secretary and Treasurer

GEORGIA

National Alliance of TV Service Association (NATESA)
5908 S. Troy St.
Chicago
Frank J. Moch,
Executive Director

DuPage County TV Association
138 W. Park St.
Elmhurst
Howard Hitzmann,
Secretary

Professional TV Servicemen's Association
7002 W. Cermak
Berwyn
Charles Doose, Secretary

Tri-City Service Dealers Association
2011 Delmar
Granite City
Myron Conyers,
Secretary

Associated Radio and Television Servicemen
433 S. Wabash Ave.
Chicago 5
Howard J. Wolfson,
Chairman

TESA of Will County
250 E. Washington St.
Joliet
L. R. McAllister

TESA of Quint Cities
532 Brady St.
Davenport, Iowa
Len Gregson, Secretary

TESA of Lake County
918 Glen Florida
Waukegan
William Rupnick,
Secretary

INDIANA

LETA of Lawrence County
1515 18th St.
Bedford
Bill Frump, President

RTTA of Grant County
600 W. Kickapoo St.
Haiford
Charles R. Schwark

Bloomington Radio-TV Service Association
304 S. Walnut St.
Bloomington
Frank Brummett, President

Indianapolis TV Technicians Association, Inc.
P. O. Box 23125
Indianapolis 23
Delbert Williams,
Secretary

TVSMA of Jackson County
804 Walnut St.
Brownstown
Forrest Stewart, President

SIETA of Jasper
Jasper
Charles Lamberson,
President

RTVSDA of Columbus
1621 California
Columbus
Dean Horn,
Secretary-Treasurer

RTSEA of Kokomo
1136 North McCann
Kokomo
Charles Conwell,
Secretary

Indiana Electronic Service Association
1017 S. Main St.
Elkhart
Lamar Zimmerman, Jr.,
Secretary

RTSEA of Logansport
530 N. Cicott St.
Logansport
Donald Hyman, Secretary

TVE of Elkhart
1136 E. Mishawaka Rd.
Elkhart
Wayne Clem, Secretary

RTSA of Muncie
R. R. 4
Muncie
Charles Ireland

RTSA of Evansville
2009 Pollock Ave.
Evansville
Ted Fink, President

ESTA of Henry County
417 N. 10 St.
New Castle
Brent Hay, Secretary

Ft. Wayne Electronics Service Association
P. O. Box 691
Ft. Wayne
John Crocker, Corresponding Secretary

ARTS of South Bend
Kordona TV
830 Portage Ave.
South Bend
Bill Rapport, President

Boone TSA
816 Story St.
Boone
Earl Scheuermann,
President

WVETA of Terre Haute
1443 S. 17 St.
Terre Haute
William Durham,
President

TESA of Cedar Rapids
118 6th St. S. E.
Cedar Rapids
Tom Cours, Secretary

Marshall County TESA
1022 S. 9th Ave.
Marshalltown
Ray Navara, Secretary

Des Moines TESA
1300 55th St.
Des Moines 11
W. L. Grommon,
Secretary

North Central TSA
10 2nd St. N. W.
Mason City
Otto Schwartz, Secretary

TESA of Ottumwa
311 S. Madison
Ottumwa
Carl Jennings, Secretary

Marshall County TESA
1022 S. 9th Ave.
Marshalltown
Ray Navara, Secretary

WAMAC, NATESA
214 E. Main St.
Dyersville
Clarence V. Benke,
Secretary

Hamilton TSA
749 2nd St.
Hamilton
William Luick

Hampton TSA
15 N. W.
Hampton
Dick Pederson, Secretary

Buena Vista TSA
210 W. Milwaukee
Storm Lake
William Roggow,
President

TESA of Blackhawk County
P. O. Box 33
Waterloo
George Argyros,
Secretary

Northeast TSA
West Union
Orville Saboe, President

KANSAS

TV Electronic Service Association of Kansas, Inc.
P. O. Box 81
Chanute
Paul Metzinger, Secretary

Ark City Chapter, TESA of Kansas
426 N. A St.
Arkansas City
Roger Thompson,
President

Southeast Chapter, TESA of Kansas
8th and Lewis Sts.
Coffeyville
W. E. Breshear, Secretary

Dodge City Chapter, TESA of Kansas
712 W. Wyatt Earp
Dodge City
Jim Carlyle, Secretary

Midwest Chapter, TESA of Kansas
2324 N. Main St.
Great Bend
Carlos Taylor, President

Hutchinson Chapter, TESA of Kansas
110 E. Sherman
Hutchinson
Lloyd Murphy, President

Junction City Chapter, TESA of Kansas
115 W. 11 St.
Junction City
James Dodd, President

Pittsburg Chapter, TESA of Kansas
1121 S. Broadway
Pittsburg
David W. Ernsbarger,
Secretary

Pratt Chapter, TESA of Kansas
605 E. 1 St.
Pratt
Stanley Gersham,
Secretary

Salina Chapter, TESA of Kansas
P. O. Box 1057
Salina
Marian Wallis, Secretary

Wichita Chapter, TESA of Kansas
841 S. Poplar St.
Wichita
Homer Miller, President

KENTUCKY

Kentuckiana Television and Radio Technicians Association, Inc.
2206 Wingfield Court
Louisville 16
Charles Simmons, Secretary

MASSACHUSETTS

ETG of Massachusetts
895 Washington
Newton 60
Gilbert Clark

Fall River Chapter, ETG
The Lane
Assonet
Henry Nadeau, President

North Shore Chapter, ETG
132 High St.
Danvers
Arthur Drolet, Secretary

Brockton Chapter, ETG
12 W. Union St.
E. Bridgewater
George W. Johnson,
President

South Shore Chapter, ETG
Broad St.
E. Weymouth
Dominic Taglieru,
Secretary

Lawrence Chapter, ETG
118 Essex St.
Lawrence
Donald Baron, President

Radio and TV Technicians Guild of Greater New Bedford
110 Topham St.
New Bedford
Ted Kurgan, Chairman,
Membership Committee

Lowell Chapter, ETG
38 Ledge Rd.
N. Chelmsford
Al Nickerson

Greater Boston Chapter, ETG
236 Main St.
Woburn
James H. Kelley,
Secretary

Worcester County Association of TV Technicians, Inc.
P. O. Box 1155
Worcester
Ed Sulkoski, Secretary

MICHIGAN

TESA of Michigan
8225 Woodward Ave.
Detroit 2
B. King, Secretary

LETA of Lenawee
234 W. Church St.
Adrian
Howard A. Merritt,
Director

TESA of Battle Creek
988 E. Michigan Ave.
Battle Creek
Richard Allman,
Secretary

South Oakland County Technicians Association
3390 W. 12 Mile Rd.
Berkley
Mike Mosier

TESA of Wayne County
8510 McGraw Ave.
Detroit 10
Howard C. Larsen,
President

TESA of Genesee County
1309 Eldorado Dr.
Flint 4
Robert Grieve, Secretary

Television Service Dealers Association, Inc.
49-40th St. N. W.
Grand Rapids 8
Clarence Lamoreaux,
Secretary

Radio and Television Association of Kalamazoo, Michigan
P. O. Box 773
Kalamazoo
Theodore Shilts, Secretary

Oakland County Electronic Association
1157 W. Huron St.
Pontiac
James Sharrow, Secretary

TESA of Saginaw
3775 N. Michigan
Saginaw
John Hooper

MINNESOTA

MINTSE (Minnesota Television Service Engineers)
P. O. Box 4429
Minneapolis 21
Warren Schei, Secretary

South Central MINTSE (District No. 2)
P. O. Box 356
Amboy
Warren Schei, Secretary

Duluth TV Radio Service Association
32 E. 4 St.
Duluth
Manley L. Koehler,
Secretary

Northeastern MINTSE (District No. 8)
1601 Woodland Ave.
Duluth 3
Manley Koehler,
Secretary

Southeastern MINTSE (District No. 1)
16 N. W. 4 St.
Faribault
Donald Folsom

Independent Radio Television Service Association
4302 Upton St.
Minneapolis 10
Donna Andrikan

Northeast and Surrounding Counties MINTSE (District No. 3)
4401 Quincy St. N. E.
Minneapolis
John W. Hemak, Director

Radio Television Service Association
202 Russell St.
Minneapolis 5
John Farmer, Secretary

South Minneapolis MINTSE (District No. 5)
5329 Penn Ave. S.
Minneapolis 19
Warren Schei

Central Minnesota Radio & TV Service Association, Inc.
23 N. Broadway
Sauk Rapids
Lee C. Meemken,
Secretary

St. Paul and Ramsey County MINTSE (District No. 4)
1319 Blair St.
St. Paul 4
Robert Rohweder

TESA of St. Paul
833 E. 7 St.
St. Paul 6
Clarence Thole

Southwestern MINTSE (District No. 7)
1016 S. 1 St.
Willmar
Erwin Larson, Secretary
and Treasurer

MISSOURI

TESA of Southwest Missouri
306 College
Greenfield
Ernest Moudy, Secretary

TESA of Central Missouri
710 Jefferson St.
Jefferson City
Vernon Towner, Secretary

Kansas City Chapter, TEAM
5367 Independence Ave.
Kansas City 24
Joe E. White, Chairman

Television Service Engineers of Greater Kansas City
2114 E. 39 St.
Kansas City 9
James R. White,
Secretary

TESA of South Central Missouri
Mountain Grove
Bill Pryor, Secretary

TESA of St. Louis
6909 Glenmore Ave.
Pine Lawn
June Alexander, Secretary

TESA of the Ozarks
854 S. Glenstone Ave.
Springfield
Benton Linder, Secretary

Electronic Association of Missouri
4134 Easton Ave.
St. Louis 13
Herman Wolf, Secretary

MONTANA

Electronic Service Association of Butte
Templer's Hall
215 N. Main St.
Butte
Harry Carroll, Recording Secretary

NEW HAMPSHIRE

Radio and TV Association of New Hampshire
334 Mitchell St.
Manchester
Emile R. Gelinas, Secretary

NEW JERSEY

Allied Electronic Technicians Association of New Jersey
P. O. Box 15
Gloucester
Joseph J. Papovich,
Secretary

Radio Servicemen's Association, Inc., of Trenton
343 William St.
Trenton 10
Michael E. Toth,
Secretary

NEW YORK

Empire State Federation of Electronic Technicians Associations, Inc.
Rural Delivery 1
Hudson Falls
Melvin Cohen, Corresponding Secretary

Television Service Association of Albany
514 2nd St.
Albany 6
Warren Baker, Secretary

Southern TIER Chapter, RSA
P. O. Box 201
Binghamton
Michael Harris, Secretary

Associated Radio-Television Servicemen of New York, Inc.
P. O. Box 32
Brooklyn 37
Peter La Presti, Secretary

Radio Television Guild of Long Island
230-08 S. Conduit Blvd.
Laurelton, Long Island
Arthur Cyr, Secretary

Mohawk Valley Radio-TV Technicians Guild
20 Allman Place
New Hartford
Stanley Niemiec,
Secretary

TV Technicians Association of Tonawanda
1032 Nash Rd.
North Tonawanda
Don Clark, Secretary

Rockland Association of TV Electronic Services
55 E. Central Ave.
Pearl River
Larry Critchlow, Secretary

Radio Technicians Association, Inc.
694 Broadway
Buffalo
Ted Telaak, President

Television and Electronic Service Association of Greater Buffalo, Inc.
Station E. Box 1182
Buffalo 11
Norm Telak, Secretary

Tompkins County Electronic Dealers Association
440 State St.
Ithaca
Ben De Young, President

TESA of Jamestown
201 E. 3 St.
Jamestown
Howard Moore, Secretary

Ulster Electronic Technicians Association
94 Furnace St.
Kingston
Charles Kohl, Secretary

Tri-County Electronic Technicians Association
28 S. Main St.
Portville
Jack Golden, Secretary

TV and Electronic Association of Rochester
P. O. Box 802
Rochester 3
Marvin Gleiner, Corresponding Secretary

Syracuse TV Technicians Association
410 Florida Road
Syracuse
Daniel Hurley, President

Electronic Technicians Association of Watertown
1830 State St.
Watertown
John Thompson, Director

STEA
Rural Delivery J
Wellsburg
Donald J. Sadler,
Secretary

NORTH CAROLINA

North Carolina Federation of Electronic Associations, Inc.
520 Main St.
Durham
Garland E. Hoke,
Secretary

Asheville TV Association
Creaseman Radio-TV Service
Asheville
Steve Creaseman,
President

Radio TV Service Association of North Carolina, Inc.
4114 Monroe Rd.
Charlotte
Don Metcalf, President

Radio TV Service Dealers Association
P. O. Box 222
E. Durham Sta.
Durham
L. L. Leathers, President

Cumberland County Radio TV Association
2908 Ft. Bragg Rd.
Fayetteville
Fred Owens, President

Greensboro TV Service Association
1742 Battleground Ave.
Greensboro
N. Shelton, Secretary

High Point Radio TV Technicians Association
1228 Montlieu Ave.
High Point
G. J. Hornaday, Secretary

North Carolina Federation of Electronic Associations, Inc.
1228 Montlieu Ave.
High Point
Garland Hoke, Secretary

Onslow TV Technicians Association
712 New Bridge St.
Jacksonville
J. E. Midgett, President

Rowan-Carbarrus Businessmen's Electronic Association
Jackson Ave.
Kannapolis
Ernest Reid, President

Surry TV Service Dealers Association
S. Main St.
Mt. Airy
Glen Thacker, Secretary
and Treasurer

Capital Area Radio TV Association
407 Peace St.
Raleigh
R. B. Corns, Secretary

Caldwell County TV Association
P. O. Box 17
Whitell
Herbert Griffin, President

Wilmington TV Service Dealers Association
c/o Sutton's TV Service
Wilmington
W. P. Sutton, President

OHIO

TESA of Ohio
2552 N. High St.
Columbus
J. P. Graham, Secretary

Ashtabula County TV Servicemen's Association
4633 Park Ave.
Ashtabula
Neil Ruppia, Secretary

TESA of Bellefontaine
503 Eastern Ave.
Bellefontaine
Harry Snyder, Secretary

TV and Electronic Service Association of Stark County
Able TV Service
1111 11th St. N. W.
Canton
Al Roberion

Chillicothe TV Technicians Association
149 W. Water St.
Chillicothe
Kenneth DeLong,
Secretary

TESA of Cincinnati
5246 Charloe Ave.
Cincinnati
Stan Shaffer, President

TESA of Greater Cleveland
P. O. Box 62
Cleveland 21
George Srdjak, Secretary

Associated Radio-TV Service Dealers
2552 N. High St.
Columbus
Ed Brownfield, Secretary

South Ohio Radio-TV Technicians Association
634 N. West St.
Hillsboro
Harry Hakes, Secretary

TESA of Mansfield Area
P. O. Box 667
Mansfield
Saul Hersch, Secretary

TESA, Lake County
1436 Mentor Ave.
Painesville
Raiph Friend, Secretary

Scioto Valley Electronic Association
W. Portsmouth TV Bldg.
1329 Galena Pk.
Portsmouth
Harvey McGlothlin,
Secretary-Treasurer

TESA of Sandusky
P. O. Box 811
245 E. Market
Sandusky
Paul G. L. Lecoy,
Director

TESA of Springfield
P. O. Box 851
Springfield
Roy Henderson, Secretary

Electronic Technicians Association of Toledo
1952 Sylvania Ave.
Toledo
Quentin Hannan,
Secretary

Urbana TV Service Association
775 Washington Ave.
Urbana
William Diehl, President

report from another
PHOTOFACT user
and member in
the PEET Program...

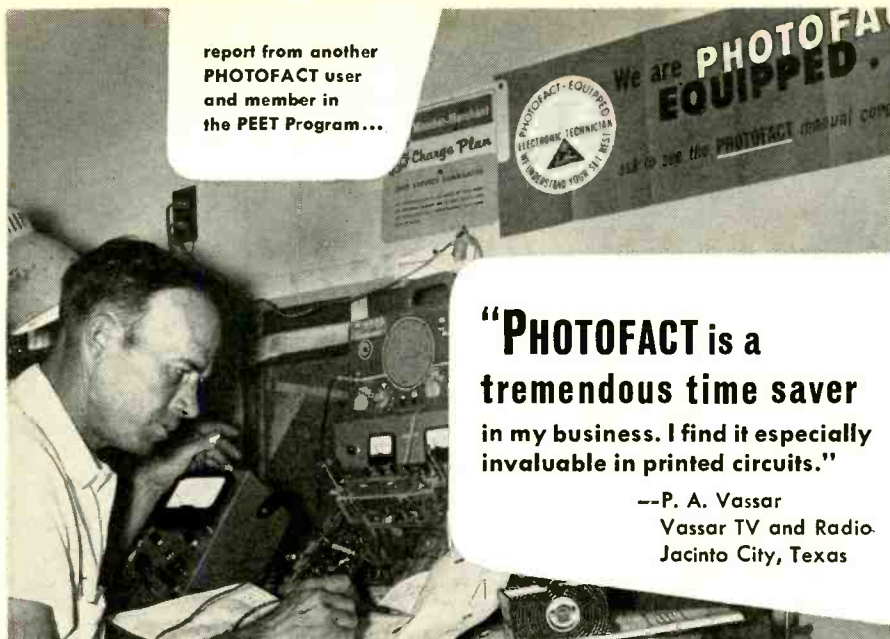

"PHOTOFACT is a tremendous time saver in my business. I find it especially invaluable in printed circuits."

—P. A. Vassar
Vassar TV and Radio
Jacinto City, Texas

Service Technicians! YOU EARN MORE... YOU RATE with the public when you own the PHOTOFACT® service data library!

You enjoy maximum earnings as the owner of a complete PHOTOFACT Service Data Library! It's inevitable, because no matter how expert you are, you can always *save more time on any job, get more jobs done daily—EARN MORE, DAY IN AND DAY OUT...*

What's more—as the owner of a complete PHOTOFACT Library, you know your customers' sets *best*. You can actually show each customer you have the PHOTOFACT Folder covering his very own set. Result: You command public respect and acceptance which paves the way to more business and earnings for you.

HOW TO STAY AHEAD...

Yes, the truly successful Service Technicians are those who own the complete PHOTOFACT Library, who can meet and solve any repair problem—faster and more profitably. And these men *keep ahead* because they're on a Standing Order Subscription with their Distributors to receive all new PHOTOFACTS as they are released monthly. (They're eligible for the benefits of membership in PEET, too—see below!)

ONLY \$10 DOWN puts the complete PHOTOFACT Library in your shop—and you have up to 30 months to pay. See your Sams Distributor today, or write to Howard W. Sams

NOW IS THE TIME TO JOIN

"PEET"

THE POWERFUL NEW PROGRAM FOR QUALIFIED TECHNICIANS

If you now own a PHOTOFACT Library or plan to own one, you can apply for membership in "PEET." It's the first industry program really designed to build powerful public acceptance for the Service Technician who qualifies. Builds enviable prestige and business for its members. Benefits cost you absolutely nothing if you qualify. Ask your Sams Distributor for the "PEET" details, or mail coupon today.

HOWARD W. SAMS & CO., INC.
1726 E. 38th St., Indianapolis 6, Ind.

- Send me full details on the new "PEET" Program.
 Send full information on the Easy-Buy Plan and Free File Cabinet deal.

- I'm interested in a Standing Order Subscription.
 I'm a Service Technician full-time; part-time

My distributor is _____

Shop Name _____

Attn: _____

Address _____

City _____ Zone _____ State _____

TESA of Dayton
2027 E. 5 St.
Dayton 3
Grady Hayes, President

TESA of Lorain County
92 E. Broad St.
Elyria
Robert A. Standen,
Secretary

TESA of Middletown, Inc.
2nd and High Sts.
Franklin,
O. Dale Burdge,
Secretary

Western Reserve Electronic Association
1856 Larchmont Ave.
Warren
A. S. Hroncheck,
Secretary

TESA of Youngstown
1742 Market St.
Youngstown
Fred Stone, Secretary

OKLAHOMA

TESA of Oklahoma
2321 S. Robinson
Oklahoma City 9
Roy Allen, Secretary

OREGON

Southwestern Oregon Television and Radio Service Association
333 S. Broadway
Coos Bay
Clyde DuPuis, Secretary

Radio-TV Service Association of Cottage Grove
1117 E. Main St.
Cottage Grove
Edward J. Coppel,
Secretary

Television and Radio Association of Klamath Falls
509 Commercial
Klamath Falls
Charles Uligh, Secretary

Oregon Television Service Association
210 N. Evans St.
McMinnville
Cliff Kadell, Secretary

Yamhill County TV Association
210 N. Evans
McMinnville
Cliff Kadell, Secretary

Pacific Northwest Community TV System, Inc.
287 S. E. 1 St.
Pendleton
Ronald Rew, Secretary

Northwest Electronic Technical Association
1233 S. E. 44 St.
Portland 15
John C. Whitesides

Television Appliance Association
424 Failing Bldg.
Portland
Roscoe E. Watts

Radio and TV Dealers Association
632 "A" St.
Springfield
Al Maurey, Secretary

Television Technicians Association of Tillamook
2108 8th St.
Tillamook
B. L. Greeson

West End Electronics Association of Eastern Oregon
P. O. Box 178
Umatilla

PENNSYLVANIA

Federation of TV-Radio Service Associations of Pennsylvania, Inc.
67 S. Main St.
Carbondale
Leon J. Helk, Secretary

Lehigh Valley Electronic Association
889 N. Graham St.
Allentown
John Zeigler, Secretary

Philadelphia Radio Servicemen's Association
127 N. 35th St.
Camden, New Jersey
William P. Humes,
Secretary

Television Service Dealers Association of Delaware County, Inc.
P. O. Box 674
Chester
Leon Skalish, Secretary

Lower Bucks County TV Service Dealers Association
1624 Newportville Rd.
Corwell Heights
Edward Zychal, President

Electronic Technicians Association of Lancaster County
P. O. Box 264
Ephrata
Gilbert L. Sweigart,
Secretary

Mid-State Electronic Service Dealers Association
17 and Herr Sts.
Harrisburg
Wayne Prather, Chairman, Board of Directors

TV Service Association of Delaware Valley
4710 Old York Rd.
Philadelphia 41
John Hadfield, Secretary

Electronic Dealers Association of Western Pennsylvania, Inc.
6026 Station St.
Pittsburgh 6
Joseph S. Doyle,
Secretary

Radio and TV Servicemen's Association of Pittsburgh, Inc.
3239 Ashlyn Ave.
Pittsburgh 4
John F. Cochran,
President

Berks County Radio Servicemen's Association
938 N. 8th St.
Reading
John G. Rader, Secretary

Lackawanna Radio TV Technicians Association
2224 Capouse Ave.
Scranton
John F. Roche, Secretary

Luzerne County Servicemen's Association
P. O. Box 309
Wilkes-Barre
Milan Krupa, Secretary

RHODE ISLAND

Rhode Island Radiomen's Business Association
425 Wilert Ave.
Riverside 15
Edward J. Oliver,
Secretary

TEXAS

Texas Electronic Association, Inc.
1513 W. 7 St.
Ft. Worth
Will A. Shaw,
Executive Secretary

Texas Electronics Association of Abilene
5002 Congress
Abilene
W. O. Arnold, Secretary

Texas Electronics Association of Austin
1911 S. Congress
Austin
Sam Allred, President
CERTA, Inc. (Certified Radio & TV Assn., Inc.)
Member of NATESA-TEA
P. O. Box 2603
Beaumont
W. E. Johnson, Secretary
Big Spring Chapter of TEA
609 Gregg St.
Big Spring
John Stanley, Secretary
TESA of Borger
214 N. Hedgecock St.
Borger
R. F. Dietz, Secretary
Conroe Chapter of TEA
P. O. Box 1125
Cleveland
Corpus Christi Chapter of TEA
P. O. Box 3013
Corpus Christi
J. R. Williams, President
Oak Cliff Chapter of TEA
4419 S. Lancaster
Dallas
TEA of Dallas
805 Exchange Bank Bldg.
Dallas 35
D. F. Comer, Secretary
Galveston Chapter of TEA
Master Radio Technicians of Galveston, Inc.
2706—J
Galveston
Roy C. Searcy, Jr.
Sabine Area TV and Radio Association
1927 Main Ave.
Groves
Henry G. Jackson, Secretary
TESA of Houston, Inc.
1822 Berry Rd.
Houston 16
Bob Koepnick, Secretary

La Marque Chapter of TEA
Mainland Television and Electronic Association
P. O. Box 491
La Marque
Ray Peterson, Secretary
Longview Chapter of TEA
504 E. Methvin
Longview
W. L. Beasley, Secretary
Harrison County Chapter of TEA
P. O. Box 431
Marshall
L. C. Totten, Jr.
Midland Chapter of TEA
Midland Association of Radio and TV Service, Inc.
311 E. Dodson
Midland
W. B. Stephens, Secretary
Hale County Chapter of TEA
508 Quincy St.
Plainview
Consolidated Services, Inc.
702 S. Flores St.
San Antonio 5
D. L. Lehmborg
San Antonio Chapter of TEA
2225 Blanco Rd.
San Antonio
Douglas Anderson, Secretary
Erath County Chapter of TEA
1400 Frey St.
Stephenville
TESA of Texarkana
P. O. Box 549
Texarkana
Dick Hoggard, Secretary
Tyler Radio & TV Association, Inc.
P. O. Box 3302
Tyler
J. F. Havard, Executive Secretary and Treasurer
Waco Chapter of TEA
1712 Franklyn
Waco

TESA of Sheboygan
1125 Indiana Ave.
Sheboygan
Fred Leonard, President
Watertown TV Association
402 Main St.
Watertown
Carl Becker, Director

Waukesha TV Association
Bilicki Radio and TV
Waukesha
Ed Bilicki, Director

CANADA

RETA of Ontario, Inc.
40 Westminster Ave.
Hamilton, Ontario
G. Leeks, Secretary
Quinte Chapter, Radio Electronic Technicians Association of Ontario, Inc.
179 W. Moira St.
Belleville, Ontario
D. Vanderwater, Secretary
Kitchener Chapter, RTA
88 Gruhn St.
Kitchener, Ontario
Howard F. Wilson, Secretary
Greater Niagara District Radio Electronic Technicians Association
25 Elberta Ave.
Niagara Falls, Ontario
R. W. Peckham, Secretary

Peterborough Chapter, RTA
482 Cordash Crescent
Peterborough, Ontario

Sudbury Chapter, RTA
27 Lisgar St.
Sudbury, Ontario
Paul Ross, Secretary

London, St. Thomas Chapter, RTA
33 Simcoe St.
St. Thomas, Ontario

Windsor Chapter, RETA
3001 Radisson Ave.
Windsor, Ontario
Otto Allemann, Membership Committee

SORRY, BUT . . .

Technicians News will not appear this month. In its place, this month only, is a complete comprehensive list of electronic service technicians associations in the United States and Canada. It is as complete and as up to date as we could possibly make it. We have tried not to miss a single group, anywhere. However, if in some way your association has not been included, please let us know so we can add you to our list.

VIRGINIA

Virginia Electronic Association
1215 Tilden Ave.
Lynchburg
Earl Talley, Secretary

WASHINGTON

TESA of Grays Harbor County
1620 W. 2 St.
Aberdeen
Leslie Graham, Secretary
Electronic Technicians Association
720 N. Jerome Lane
East Wenatchee
Richard Jones, President
TESA of Snohomish County
2911 Rucker St.
Everett
Clifford Wold, President
Electronics Technicians Association of Cowlitz County
1228 12th Ave.
Longview
Ansel Heckman, Secretary
Washington State Electronic Council
c/o Heckman Radio and TV Service
Longview
Ansel Heckman, Secretary-Treasurer

King County TV Service Association, Inc.
500 E. Pine
Seattle 22
James O. Humphrey, Secretary
TESA of Spokane County
12508 East Sprague
Spokane
Verne Slichter, President
Radio and Television-Electronics Institute of Washington
3302 S. Tacoma Way
Tacoma
Russell Johnson, Executive Manager
TESA of Yakima County
1111 S. 9 St.
Yakima
Charles Crabtree, Secretary

WISCONSIN

Indianhead Radio-TV Servicemen's Association
Rural Free Delivery
Colfax
Vernon Christian, Secretary
TESA of Green Bay
1226 S. Broadway
Green Bay
Dean Ridgley, President
TESA of Janesville
222 W. Milwaukee
Janesville
Dave Lewis, Director

Platteville TV Association
Foster Radio and TV
Lancaster
Marvin Foster, President
TESA of Milwaukee
P. O. Box 91
Station F
Milwaukee
Dan Smith, Secretary
TESA of Wisconsin, Inc.
P. O. Box 6091
Milwaukee
Gerald Hall, President

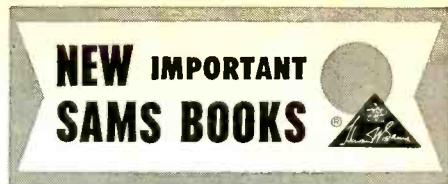

SOLVES YOUR HORIZONTAL-SWEEP PROBLEMS

101 Key Troubleshooting Waveforms for Horizontal-Sweep Circuits



by Bob Middleton
Second volume in the new series by this popular writer. Covers the four most typical horizontal-sweep circuits: 90°, 110°, direct-drive and primary-secondary transformer. Shows the normal waveform at key checkpoints; then shows 101 abnormal waveforms (and voltage changes) and ties them directly to specific component defects. By comparing the waveforms you obtain at various circuit points with those shown in the book, you can spot the defective component in minutes! Also included are circuit symptoms, tests, evaluations of results, and valuable supplementary notes. Keep this book near your scope, and you'll never again be baffled by horizontal-sweep troubles. 128 pages; 136 illustrations; 5 1/2 x 8 1/2". Only \$2.00

NEWEST LIGHT ON A TOUGH PROBLEM

Eliminating Man-Made Interference



by Jack Darr
Noise and interference often play havoc with radio and TV reception, causing customer dissatisfaction. Here, at last, is the book that gives you the proper corrective know-how. It covers the entire subject of man-made interference—what it is, how it originates, how it is transmitted, how to track it to a source, and how to eliminate or minimize its disturbing effects. Ten chapters cover in detail what to do about noise and interference in home radios and TV sets; audio amplifiers; two-way mobile radio systems; auto, aircraft, and marine radios; electro-mechanical and geophysical apparatus, etc. Two other chapters include actual case histories, illustrated with many photos showing TV picture interference. This book is the first to guide you to the root of practically any man-made interference problem—pays for itself over and over again. Invaluable also in the industrial electronics and ham fields. 160 pages; 5 1/2 x 8 1/2". Only \$2.95

JUST PUBLISHED—NEW VOLUME 8

Dial Cord Stringing Guide

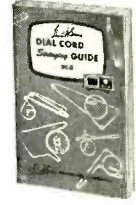

Dial cord stringing got you tied up in knots? You can sidestep the problem with this handy workbench guide. Latest Volume 8 includes 214 diagrams showing how to string dial cords in 1959-60 radio and TV receivers. Cumulative index included, covering Vols. 5 through 8. 80 pages; 5 1/2 x 8 1/2". Only \$1.00

Vols. 1-7 are also available at \$1.00 each.

HOWARD W. SAMS & CO., INC.

Order from your Sams Distributor today, or mail to Howard W. Sams & Co., Inc., Dept. A-21, 1720 E. 38th St., Indianapolis 6, Ind.

- Send me the following books:
- 101 Key Troubleshooting Waveforms for Hor.-Sweep Circuits (WFM-2)
 - Eliminating Man-Made Interference (MMD-1)
 - Dial Cord Stringing Guide, Vol. 8 (DC-8)
- \$ enclosed. Send Free Book List

Name _____
Address _____
City _____ Zone _____ State _____



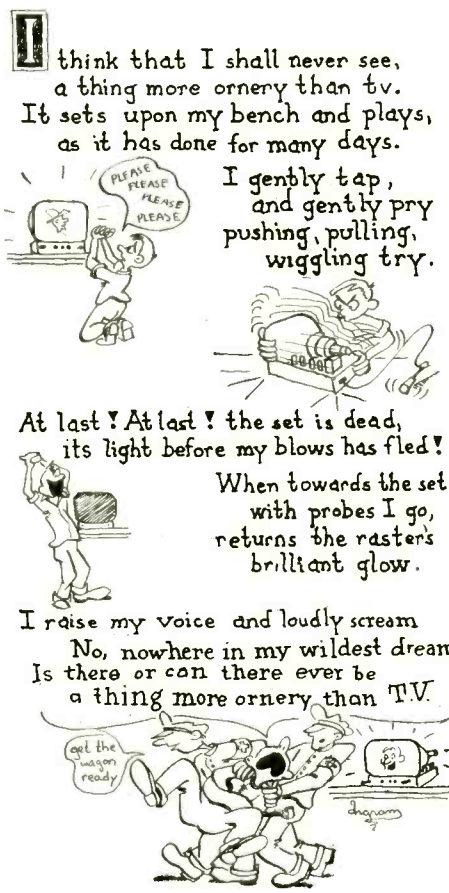

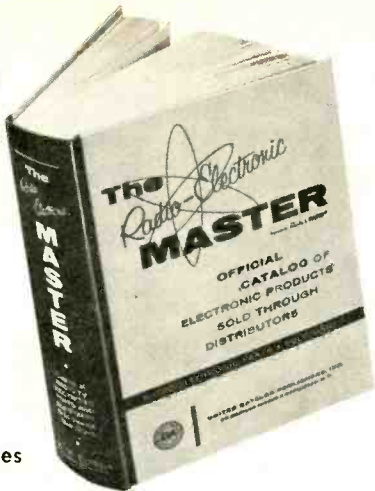
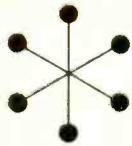
(Outside U.S.A. priced slightly higher)





1600 pages



- 
IT'S NEW. Covers all the latest products: • miniature and sub-miniature components • printed circuit components • silicon rectifiers • new transistor types • citizens band, SSB and new mobile ham gear • microwave and telemetering components and equipment • stereo equipment ... every new electronic product for servicing, experimenting, design, industrial and military applications.
- 
IT'S THE WORLD'S BIGGEST ELECTRONIC CATALOG. 1600 pages—more than 175,000 items—with specifications, illustrations and prices. Contains hundreds of items not found in smaller catalogs.
- 
IT'S THE EASIEST TO USE. Quickest way to get current catalog data on the products of more than 330 manufacturers. Systematically organized in 32 product sections for rapid reference.
- 
IT'S INDISPENSABLE TO SERVICE MEN, ENGINEERS, HOBBYISTS. If you're a service technician, The MASTER means more profitable operation because it covers all items necessary for radio, TV, audio and industrial servicing. If you're an engineer or buyer, you'll save design and purchasing time. If you're a ham, hobbyist or experimenter, you'll get the right product to do the job best, because you're shopping in the electronic supermarket.

AND IT'S NOW AVAILABLE AT
YOUR LOCAL DISTRIBUTOR

1961 MASTER

\$3.95 at parts distributors
\$4.95 in Canada

FREE from your distributor: New Foreign Tube Interchangeability Guide, or write direct, enclosing 25c.

RADIO-ELECTRONIC MASTER — 60 MADISON AVE., HEMPSTEAD, N. Y.

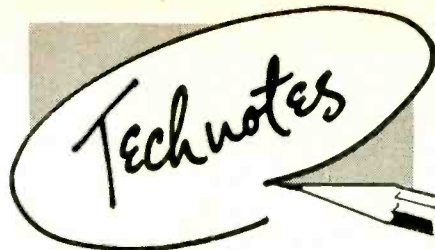

RCA 21CD7000 SERIES

Color shading in this set is usually traced to a sawtooth voltage appearing at the red or blue pix-tube grids. This can be caused by R713, 470,000 ohms, in the killer plate circuit

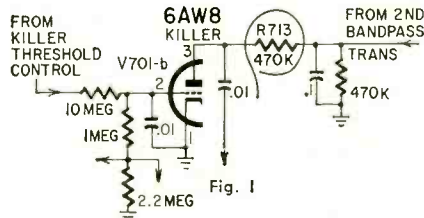

changing in value (Fig. 1) or C733, C734 or C738 (.047 μ f) in the R - Y, B - Y and G - Y amplifier plate circuits changing more than 20% in value (Fig. 2). Color shading

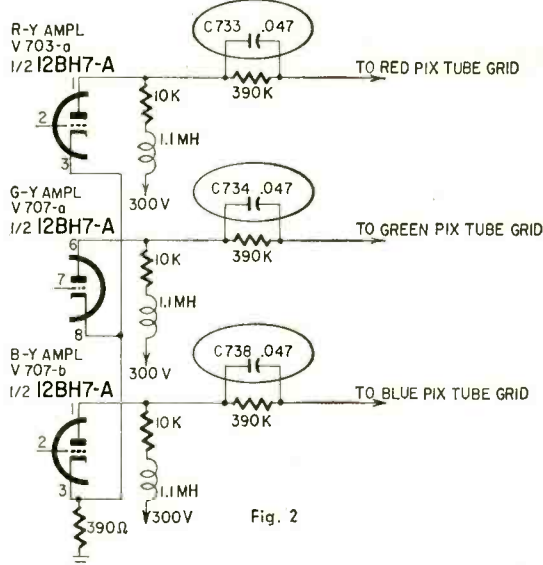

caused by R713 changing in value appears on color programs and shows up as a color change in an object as the camera pans across the scene.—Warren Roy

HOFFMAN 331

On several of these models, no sound or intermittent sound has been caused by a shorted capacitor inside the ratio-detector transformer can. This capacitor, marked C101 on some of the manufacturer's schematics, is across the primary winding of the transformer and is composed of two small plates separated by a thin coated sheet of mica. If the mica shorts, the sound may vary intermittently or go out entirely. Our solution is to bend the top plate of the capacitor upward so it does not touch the bottom plate, and remove the mica sheet. A 100- μ f button type ceramic capacitor is then installed (either inside the can or across its terminals externally). A slight readjustment of the transformer slugs is necessary for peak output and minimum hum level.—John B. Ledbetter

SHORTCUT MAKES HUM

Recently, I replaced the volume control in an Espey model 511-B AM-FM radio. One end of the control was connected to the chassis near the grounded cathode of the 6SQ7 through a 4-inch length of wire. Installing the new control, I went ahead and removed the ground wire and used the ground strap supplied with the new control.

**COMPLETELY NEW
DIFFERENT!
EXCITING!**

**Men-Women
17-55**

**NO ADVANCED
EDUCATION NEEDED!**

To help you EARN GOOD MONEY later in industry, DeVry's modern training provides a thorough grounding in basics . . . then develops your skill. Thus, there is no need for advanced education or previous technical experience at the start. Whether you train in your spare time at home or in our well-equipped Chicago or Toronto Laboratories, DeVry helps you become a well-trained technician, ready for a real career in Electronics.

NEW! ALL NEW!

Shown below is the valuable new combination oscilloscope and voltmeter which DeVry Tech men build during the new "space" training program. But that's not all! New movies, new subjects, new texts, new experimental projects—all prepare you thoroughly in this latest and greatest DeVry Tech training program.

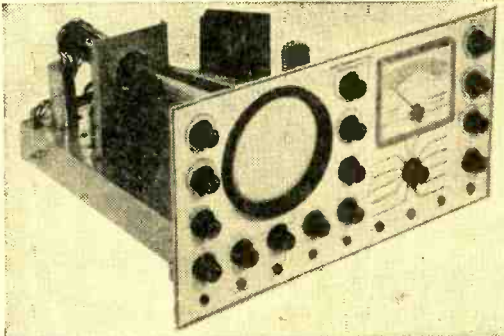

Effective Employment Service

When your training is completed our Employment Service helps you get started in Electronics. Yes, you get the same effective nationwide employment aid that has helped so many men in the past toward good jobs or a business of their own.

DRAFT AGE?

If you are subject to military service, mark the coupon. We have valuable information for you.

**MAIL
TODAY!**

2 FREE BOOKLETS

**GIVE YOU FACTS ON
HOW YOU MAY GET STARTED!**

Prepare Now for a **REAL** Job
in **Space and
MISSILE
Electronics**
from
RADIO to ROCKETRY

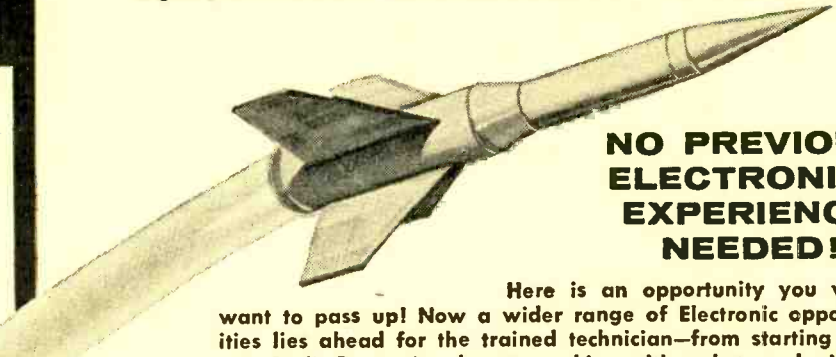

**NO PREVIOUS
ELECTRONICS
EXPERIENCE
NEEDED!**

Here is an opportunity you won't want to pass up! Now a wider range of Electronic opportunities lies ahead for the trained technician—from starting your own Radio-Tv service shop to working with rockets and missiles . . . from industrial electronics to space electronics. And make no mistake about it, this is one of the largest and finest opportunity fields of our time. Here, trained technicians are in demand, to build, install, service and maintain all sorts of equipment used in Communications, Radar, Broadcasting, Automation, Industrial Electronics . . . and the exciting developments in Space and Missile Electronics. Now DeVry makes it possible for you to prepare for just such opportunities. Check the fields that interest you on the coupon below, and mail TODAY. You'll get honest-to-goodness FACTS about your chances of preparing for a better career in Electronics.

**FOR
MORE
FACTS!**

DeVry Technical Institute

4141 Belmont Ave., Chicago 41, Ill., Dept. RE-1-R



Please give me your two free booklets, "Pocket Guide to Real Earnings" and "Electronics in Space Travel!"; also include details on how to prepare for a career in Electronics. I am interested in the following opportunities (check one or more):

- Space & Missile Electronics
- Radar
- Computers
- Special "Short Courses"
- Television and Radio
- Automation Electronics
- Broadcasting
- Microwaves
- Communications
- Industrial Electronics

Name _____ Age _____
 Please Print
 Address _____ Apt. _____
 City _____ Zone _____ State _____

Check here if you face military service. Canadian residents: Write DeVry Tech of Canada, Ltd., 970 Lawrence Avenue West, Toronto 19, Ontario.

**DeVRY
OFFERS**

Electronics Training

FROM BASICS TO OUTER SPACE ROCKETRY!

Not only the basic applications of electronics like Radio and TV, but also the satellites, space ships, guided missiles, all depend on Electronics Technicians who install, adjust, maintain and repair the equipment needed. What other job can be so exciting, profitable and promising? Yet many men, 17-55, can now train the DeVry way at home for such jobs—without previous technical experience or advanced education.

DeVRY TECH PRESIDENT VISITS MISSILE FACILITIES!

Mr. T. J. Lafeber, DeVry's President, is shown here at missile test stand. During an inspection tour, he was deeply impressed with the role that is being played in national defense by electronic technicians.

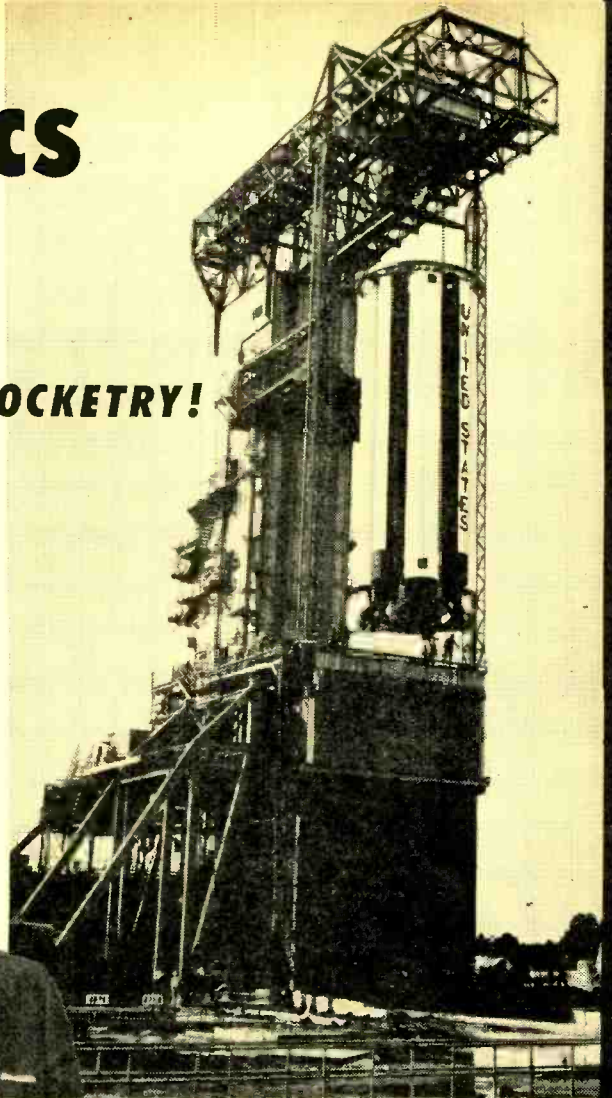

WHAT SOME DeVRY TECH GRADUATES ARE DOING!

Edward Hahn, Illinois, was a laborer. Now he is an Electronic Project Engineer with the Martin Company, a large producer of missiles.

Dale L. Gawthorpe, Illinois, left a clerk's job to take the DeVry program. He is now enjoying his work with automatic pilot equipment at Sperry Phoenix Company.

Charles Morishita, Oregon, worked as a farmer before taking DeVry's training. Now he builds and tests equipment at Lockheed's Space and Missile Division.

George D. Crouch, California, was a retail store clerk. He took the DeVry training program and today he is doing very well with his own business in the servicing field.

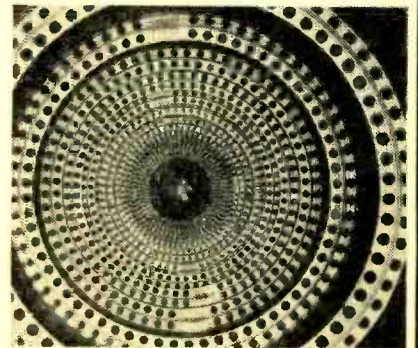

A RARE VIEW! This inside view of a ballistic missile is seldom seen by a civilian. It's a sight that greatly impressed Mr. Lafeber.

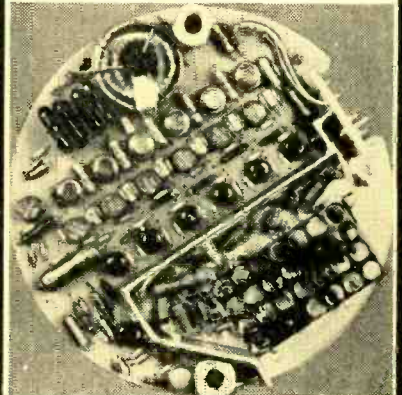

THE HEART OF THE MISSILE! Missile wiring soon becomes clear to a DeVry Tech man because he learns basic circuits by use of the "Electro-Lab," a training device that helps speed up learning.

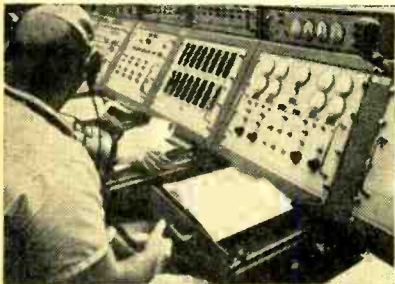

THE COUNT DOWN! Here is a control panel for missile tests. Missile check-out and adjustment are largely the work of the Electronics Technician.

SEND FOR 2 FREE BOOKLETS!

Postage
Will be Paid
by
Addressee

No
Postage Stamp
Necessary
If Mailed in the
United States

BUSINESS REPLY MAIL

First Class Permit No. 4148, Chicago, Ill.

DeVry Tech
4141 Belmont Avenue
Chicago 41, Illinois

**DON'T
DELAY!
MAIL
TODAY!**

When the job was finished, there was pronounced hum that was not present originally. At first I couldn't understand where it came from. Later on I figured out the reason and eliminated the hum.

The triple-section filter capacitor, whose can is common negative and grounded, is mounted near the volume control. The center tap of the high-voltage winding of the power transformer is grounded at a point rather distant from the filter capacitor ground. This results in a strong, pulsating dc flowing through the chassis which now became the common return for the ac signal from the volume control back to the grounded cathode of the 6SQ7. Removing the ground strap from the control and reconnecting the original ground wire cured the trouble.

A hard-hitting reminder that shortening leads in audio circuits isn't always best.—*Carl C. Seidler*

BENDIX FM 27C

The set was pulled after a new yoke failed to cure a keystone pattern. Ordinarily most such symptoms arise from a partly shorted yoke but this one didn't.

The waveforms at the screen grid and cathode of the horizontal output tube gave the first clue to the trouble—the screen grid and cathode waveforms were fuzzy. Resetting

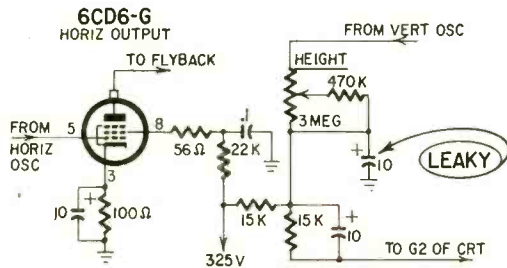

the scope sweep to half the vertical rate showed a rather heavy vertical signal synchronized with the low sweep rate. The vertical decoupling capacitor (height control circuit) was replaced after shunting it failed to eliminate the symptom completely. The new capacitor was a single-section replacement soldered in by its pigtailed as the original unit seemed to be leaking to the remaining sections.—*Lawrence Shaw*

MARK II REALIST PHONO

Complaint: Picks up 96-mc FM broadcast station, amplifier cannot be controlled by volume control.

Solution: Replace the 0.1-μf paper capacitor in the grid circuit of the 12AX7 input stage with a metallized type and ground the shell to chassis.—*Lester J. Barthelmess*

OLDSMOBILE TRANSPORTABLE

Works as portable, dead in car. All voltages check out OK.

This common trouble calls for inspecting the slide contacts on the power unit with a magnifying glass. You will probably find a fine break in one or more of the contacts. Replace the slide, don't try to repair the old one.—*Wm. Porter*

PHILCO AUTO RADIOS

When one of these sets has a low, distorted output, check to see if it uses an AR5 output transistor. If it does, look for a charred 0.47-ohm bias resistor. If you find one, replace the AR5 with a later run of the same transistor or with a 2N256. Also replace the bias resistor.—*Wm. Porter* END

Readers of our December issue were no doubt surprised to see on page 50 immediately following the R-E printed-circuit preamplifier article, an announcement that such a story would also appear in January. We have not become as preamp-minded as all that; the story announced was indeed the one that you had just finished reading! Originally planned for January, we found it possible to put it in the December issue, but forgot to kill the announcement. Our apologies if we have misled any would would-be constructors into waiting to compare the two preamps.

BECOME A RADIO TECHNICIAN

for only \$26.95

BUILD 20 RADIO

CIRCUITS AT HOME

with the New Progressive

RADIO "EDU-KIT"®

All Guaranteed to Work!

PRACTICAL only

HOME \$26.95

RADIO

COURSE



Reg. U.S. Pat. Off.

NOW INCLUDES

- ★ 12 RECEIVERS
- ★ 3 TRANSMITTERS
- ★ SQ. WAVE GENERATOR
- ★ AMPLIFIER
- ★ SIGNAL TRACER
- ★ SIGNAL INJECTOR
- ★ CODE OSCILLATOR

TRAINING ELECTRONICS TECHNICIANS SINCE 1936

- ★ No Knowledge of Radio Necessary
- ★ No Additional Parts or Tools needed
- ★ Excellent Background for TV
- ★ School Inquiries Invited
- ★ Attractively Gift Packed

FREE EXTRAS

- SET OF TOOLS ● RADIO & ELECTRONICS TESTER ● ELECTRIC SOLDERING IRON ● TESTER INSTRUCTION MANUAL ● MEMBERSHIP IN RADIO-TV CLUB: CONSULTATION SERVICE ● HI-FI GUIDE ● QUIZZES ● TV BOOK ● FCC AMATEUR LICENSE TRAINING ● RADIO BOOK ● PRINTED CIRCUITRY ● PLIERS-CUTTERS ● ALIGNMENT TOOL ● WRENCH SET ● CERTIFICATE OF MERIT ● VALUABLE DISCOUNT CARD

WHAT THE "EDU-KIT" OFFERS YOU

The "Edu-Kit" offers you an outstanding PRACTICAL HOME RADIO COURSE at a rock-bottom price. Our kit is designed to train Radio & Electronics Technicians, making use of the most modern methods of home training. You will learn radio theory, construction, servicing, basic Hi-Fi and TV repairs, code, FCC amateur license requirements.

You will learn how to identify radio symbols, how to read and interpret schematics, how to mount and lay out radio parts, how to wire and solder, how to operate electronic equipment, how to build radios. Today it is no longer necessary to spend hundreds of dollars for a radio course. You will receive a basic education in radio, worth many times the small price you pay, only \$26.95 complete.

THE KIT FOR EVERYONE

The Progressive Radio "Edu-Kit" was specifically prepared for any person who has a desire to learn Radio. The "Edu-Kit" has been used successfully by young and old in all parts of the world, by many Radio Schools and Clubs in this country and abroad, is used for training and rehabilitation of Armed Forces Personnel and Veterans throughout the world.

The Progressive Radio "Edu-Kit" requires no instructor. All instructions are included. Every step is carefully explained. You cannot make a mistake.

PROGRESSIVE TEACHING METHOD

The Progressive Radio "Edu-Kit" is the foremost educational radio kit in the world, and is universally accepted as the standard in the field of electronics training. The "Edu-Kit" is based on the educational principle of "Learning by Doing". Therefore, you will construct radio circuits, perform jobs and conduct experiments to illustrate the principles which you learn.

You begin by examining the various radio parts included in the "Edu-Kit." You then learn the function, theory and wiring of these parts. Then you build a simple radio. With this first set, you will enjoy listening to regular broadcast stations, learn theory, practice testing and troubleshooting. Then you build a more advanced radio, learn more advanced theory and techniques. Gradually, in a progressive manner, and at your own rate, you will find yourself constructing more advanced multi-tube radio circuits, and doing work like a professional Radio Technician.

Included in the "Edu-Kit" course are twenty Receiver, Transmitter, Code Oscillator, Signal Tracer, Signal Injector, Square Wave Generator and Amplifier circuits. These are not unprofessional "breadboard" experiments, but genuine radio circuits, constructed by means of professional wiring and soldering on metal chassis, plus the new method of radio construction known as "Printed Circuitry." These circuits operate on your regular AC or DC house current.

In order to provide a thorough, well-integrated and easily-learned radio course, the "Edu-Kit" includes practical work as well as theory; troubleshooting in addition to construction for fun; whether your purpose in learning radio be for hobby, business or job; progressively-arranged material, ranging from simple circuits to well-advanced topics in Hi-Fi and TV. Your studies will be further aided by Quiz materials and an excellent FREE Consultation Service.

THE "EDU-KIT" IS COMPLETE

You will receive all parts and instructions necessary to build 20 different radio and electronics circuits, each guaranteed to operate. Our Kits contain tubes, tube sockets, variable, electrolytic, mica, ceramic and paper dielectric condensers, resistors, tie strips, coils, hardware, tubing, punched metal chassis, Instruction Manuals, hookup wire, solder, selenium rectifiers, volume controls, switches, knobs, etc.

In addition, you receive Printed Circuit materials, including Printed Circuit chassis, special tube sockets, hardware and instructions. You also receive a useful set of tools, a professional electric soldering iron, and a self-powered Dynamic Radio & Electronics Tester. The "Edu-Kit" also includes Code Instructions and the Progressive Code Oscillator, in addition to the F.C.C. type Questions and Answers for Radio Amateur License training. You will also receive lessons for servicing with the Progressive Signal Tracer and the Progressive Signal Injector, and a High Fidelity Guide and Quiz Book. Everything is yours to keep.

J. Statistis, of 25 Poplar Pl., Waterbury, Conn., writes: "I have repaired several sets for my friends, and made money. The "Edu-Kit" paid for itself. I was ready to spend \$240 for a Course, but I found your ad and sent for your Kit."

UNCONDITIONAL MONEY-BACK GUARANTEE

The Progressive Radio "Edu-Kit" has been sold to many thousands of individuals, schools and organizations, public and private, throughout the world. It is recognized internationally as the ideal radio course.

By popular demand the Progressive Radio "Edu-Kit" is now available in Spanish as well as English.

It is understood and agreed that should the Progressive Radio "Edu-Kit" be returned to Progressive "Edu-Kits" Inc., for any reason whatever, the purchase price will be refunded in full, without quibble or question, and without delay.

The high recognition which Progressive "Edu-Kits" Inc. has earned through its many years of service to the public is due to its unconditional insistence upon the maintenance of perfect engineering, the highest instructional standards, and 100% adherence to its Unconditional Money-Back Guarantee. As a result, we do not have a single dissatisfied customer throughout the entire world.

ORDER FROM AD—RECEIVE FREE BONUS RESISTOR AND CONDENSER KITS WORTH \$7.00

Send "Edu-Kit" Postpaid. I enclose full payment of \$26.95.
 Send "Edu-Kit" C.O.D. I will pay \$26.95 plus postage.
 Send me FREE additional information describing "Edu-Kit."

Name: _____

Address: _____

Progressive "EDU-KITS" Inc. 1186 Broadway, Dept. 172G
Hewlett, N. Y.

**THE EVOLUTION OF
A FAMOUS
TAPE RECORDER**



the *Norelco*®

CONTINENTAL

"400" a new
4-track stereo-record/
stereo-playback
tape recorder
guild-crafted for you by
Philips of the Netherlands

(MODEL EL 3536)
SPECIFICATIONS

- ◆ Four-track stereophonic or monophonic recording and playback
- ◆ Three tape speeds — 1 7/8, 3 3/4 and 7 1/2 ips
- ◆ Completely self-contained, including dual recording and playback preamplifiers, dual power amplifiers, two Norelco wide-range loudspeakers (second in lid) and stereo dynamic microphone (dual elements)
- ◆ Can also be used as a quality stereo hi-fi system with tuner or record player.

For additional descriptive literature write to:
North American Philips Co., Inc.
High Fidelity Products Division
230 Duffy Avenue
Hicksville, L. I., N. Y.



**NEW
TUBES and
SEMI-CONDUCTORS**

WE have a wide range of entertainment and industrial types this month. There's a high-mu triode twin for audio pre-preamps and a p-n-p transistor for 450-kc and 10.7-mc circuits. On the industrial side are a group of 90-watt power transistors and a twin power-pentode for use at frequencies up to 500 mc.

Entertainment types

A short but interesting listing starts with an audio twin-triode and closes with a twin-diode high-mu triode.

2N1515

A p-n-p post alloy diffusion transistor especially designed for use in 450-kc and 10.7-mc if stages. Output impedance is such that usually neutralization is not required.

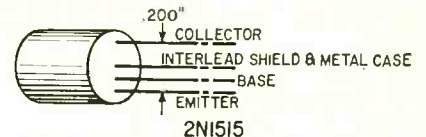

Maximum ratings of this Amperex transistor at (25° C) are:

V _{CS}	20
I _C (ma)	10
I _E (ma)	10
P _C (mw)	83

Characteristics of the 2N1515 when V_{CE} = 6, I_B = 1 ma are:

f _T (cutoff frequency) (mc)	70	
G _o (power gain) (db at 10.7 mc)	28	
	(db at 455 kc)	61
NF (noise figure) (db at 10.7 mc)	8	
	(db at 455 kc)	8

20EZ7

A high-mu twin triode, in a 9-pin

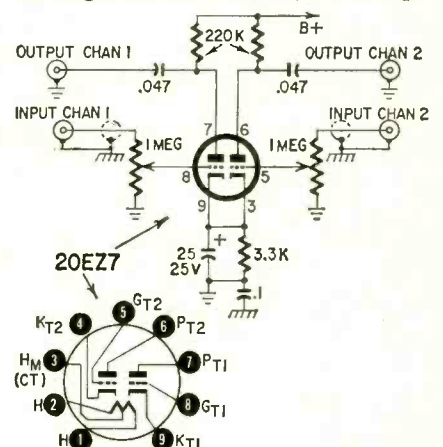

**Purchasing
A HI-FI
SYSTEM?**

TIME PAYMENTS AVAILABLE

Up to 2 years to pay!

Send Us
Your
List Of
Components
For A
Package
Quotation

- Jim Lansing*
- Altec Lansing
- Electrovoice
- Superscope
- Hartley • Viking
- University • Jensen
- Acoustic Research
- Janszen
- Wharfedale
- USL Citizen Band
- Gonset • Hallicrafter
- Texas Crystals
- Concertone
- Bell • G.E.
- Weathers
- Harman-Kardon
- Eico • Pilot
- Acrosound
- Quad Ampl & Spkr*
- Dual Changer
- Bogen • Leak
- Dynakit • Fisher
- H. H. Scott
- Thorens* Sherwood*
- TEC • Roberts
- Amplex • DeWald
- Sony • Tandberg*
- Challenger
- Wollensak
- Garrard
- Miracord
- Glaser-Steers
- Rek-O-Kut
- Components
- Norelco
- Fairchild
- Pickering • Gray
- Audio Tape
- Magnecord*
- Artizan Cabinets
- Rockford Cabinets

WE WON'T BE
UNDERSOLD!

All merchandise is
brand new, fac-
tory fresh & guar-
anteed.

Free Hi-Fi Catalog

**AIREX
RADIO
CORPORATION**

64-RE Cortlandt St., N.Y. 7, CO 7-2137

Ask By Name For

GENUINE

your assurance
of brand name
quality

**"NO NOISE"
PRODUCTS**



**NO-NOISE
VOLUME CONTROL
and CONTACT
RESTORER**

- Cleans • Lubricates
 - Protects
 - Not a Carbon Tet
Solution
- 2 oz. Bottle \$1.00
6 oz. Spray Can \$2.25
Net to Servicemen

**NO-NOISE
TUNER-TONIC
with PERMA-FILM**

- Cleans, lubricates, restores all tuners, including wafer type.
- Non-toxic, non-inflammable.
- For TV, radio and FM use.
- Economical — a little does a lot.



6 oz. Aerosol Can
\$3.25
Net to Servicemen



**FREE
at your jobbers
5" PLASTIC
EXTENDER**

- Push Button Assembly
- For Pin-Point Applications
- Does Not Cause Shorts

ELECTRONIC CHEMICAL CORP.

813 Communipaw Avenue Jersey City 4, N. J.

miniature envelope, especially designed for use in high-gain resistance-coupled low-level audio amplifiers such as pre-amps for low-cost stereo phonographs. The diagram shows the RCA 20EZ7 in just such a circuit.

Maximum ratings of the tube (each triode) in class-A1 amplifier service are:

V_H (series)	20
I_H (series) (ma)	100
V_H (parallel)	10
I_H (parallel) (ma)	200
V_P	330
V_G (neg bias value)	55
V_G (pos bias value)	0
P_P (watts)	1.2

Characteristics at 100 volts plate voltage and -1 volt on the grid are:

μ	100
g_m (μ mhos)	1,250
R_p (ohms)	80,000

14GT8

A twin-diode, hi- μ triode of the 9-pin miniature type intended for use in FM receivers. The two diodes serve in ratio-detector or discriminator circuits—the triode as an audio-frequency amplifier. Each unit has its own cathode.

Characteristics of the triode section of the RCA 14GT8 when it is used in

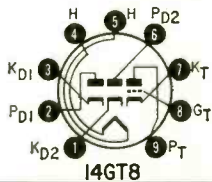

class-A1 amplifier service are:

V_P	250
V_G	-3
μ	72
R_p (ohms)	72,000
g_m (μ mhos)	1,000
I_P (ma)	0.7

Maximum ratings of the diodes are:

I_P (ma)	5
Peak heater-cathode voltage with heater either positive or negative with respect to cathode	200

Industrial types

Two groups of power transistors, a twin power pentode and a description of a new type of mesa transistor.

6939

A twin power pentode in a 9-pin miniature envelope with two built-in neutralizing capacitors. The tube, which has a common cathode and screen and suppressor grids, is designed for push-

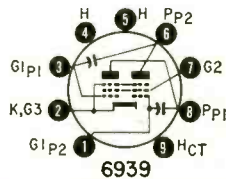

pull power-amplifier service or frequency-multiplier use in communications equipment at frequencies up to 500 mc. It can deliver 5 watts in continuous commercial service (CCS) or 6 watts in intermittent commercial and amateur service (ICAS).

"New 1961 Catalog"

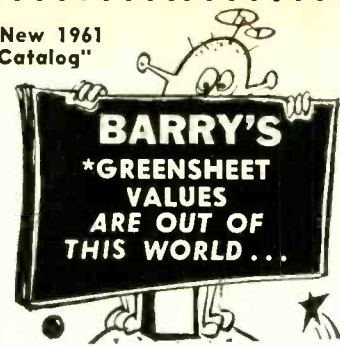

- ★ A complete catalog of specialized industrial Electronic TUBES and COMPONENTS... featuring Barry Electronics savings to Industry, Servicemen and Experimenters.
- We have thousands of tube types in stock. First Quality at Sensible Prices. Buy with confidence.
- Prove these values to yourself! Complete and mail the coupon below for your copy of the *Greensheet.
- We'll also purchase your equipment and unused tubes. Send details: BARRY ELECTRONICS CORP. 512 Broadway, New York 12, N.Y. Dept. RE-1
- Please send me a copy of the new 1961 *Greensheet and add my name to your mailing list.

(RE-1)
Name..... Title
Company.....
Address.....
City..... State

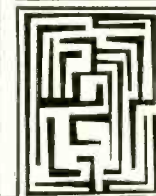

YOU'LL BE AMAZED...

at our low, low hi-fi prices. Write for FREE discount catalog A-12, or send for our special quotations on your component needs. KEY ELECTRONICS COMPANY 120 Liberty St., New York 6, N.Y.

TV-RADIO Servicemen or Beginners...

Send for *Coyne's* 7-Volume Job-Training Set on 7-Day **FREE TRIAL!**



The First Practical TV-RADIO-ELECTRONICS Shop Library!

Answers ALL Servicing Problems QUICKLY... Makes You Worth More On The Job!

Put money-making, time-saving TV-RADIO-ELECTRONICS know-how at your fingertips—examine Coyne's all-new 7-Volume TV-RADIO-ELECTRONICS Reference Set for 7 days at our expense! Shows you the way to easier TV-Radio repair—time saving, practical working knowledge that helps you get the BIG money! How to install, service and align ALL radio and TV sets, even color-TV, UHF, FM and transistorized equipment. New photo-instruction shows you what makes equipment "tick". No complicated math or theory—just practical facts you can put to use immediately right in the shop, or for ready reference at home. Over 3000 pages; 1200 diagrams; 10,000 facts!

SEND NO MONEY! Just mail coupon for 7-Volume TV-Radio Set on 7-Day FREE TRIAL! We'll include the FREE BOOK below. If you keep the set, pay only \$3 in 7 days and \$3 per month until \$27.25 plus postage is paid. Cash price only \$24.95. Or return set at our expense in 7 days and owe nothing. Either way, the FREE BOOK is yours to keep. Offer limited, so act NOW!

"LEARNED MORE FROM THEM THAN FROM 5 YEARS WORK!"

"Learned more from your first two volumes than from 5 years work."
—Guy Bliss, New York

"Swell set for either the serviceman or the beginner. Every service bench should have one."
—Melvin Masbruch, Iowa.

FREE DIAGRAM BOOK!

We'll send you this big book, "150 Radio-Television Picture Patterns and Diagrams Explained" ABSOLUTELY FREE just for examining Coyne's 7-Volume Shop Library on 7-Day FREE TRIAL! Shows how to cut servicing time by reading picture-patterns, plus schematic diagrams for many TV and radio sets. Yours FREE whether you keep the 7-Volume Set or not! Mail coupon TODAY!



Like Having An Electronics Expert Right At Your Side!

- VOL. 1—EVERYTHING ON TV-RADIO PRINCIPLES! 300 pages of practical explanations; hundreds of illustrations.
- VOL. 2—EVERYTHING ON TV-RADIO-FM RECEIVERS; 403 pages; fully illustrated.
- VOL. 3—EVERYTHING ON TV-RADIO CIRCUITS! 336 pages; hundreds of illustrations, circuit diagrams.
- VOL. 4—EVERYTHING ON SERVICING INSTRUMENTS! How they work, how to use them. 368 pages; illustrated.

- VOL. 5—EVERYTHING ON TV TROUBLESHOOTING! Covers all types of sets. 437 pages; illustrations, diagrams.
- VOL. 6—TV CYCLOPEDIA! Quick and concise answers to TV problems in alphabetical order, including UHF, Color TV and Transistors; 868 pages.
- VOL. 7—TRANSISTOR CIRCUIT HANDBOOK! Practical Reference covering Transistor Applications; over 200 Circuit Diagrams; 410 pages.

ALL 7 BOOKS HAVE BRIGHT, MODERN, VINYL CLOTH WASHABLE COVERS

FREE BOOK—FREE TRIAL COUPON!

Educational Book Publishing Division
COYNE ELECTRICAL SCHOOL
1455 W. Congress Parkway, Dept. II-T1, Chicago 7, Illinois

Yes! Send me COYNE'S 7-Volume Applied Practical TV-RADIO-ELECTRONICS Set for 7-Days FREE TRIAL per your offer. Include "Patterns & Diagrams" book FREE!

Name Age
Address
City Zone State

Check here if you want Set sent C.O.D. Coyne pays postage on C.O.D. and cash orders. 7-Day Money-Back Guarantee.

Coyne ELECTRICAL SCHOOL

1455 W. Congress Parkway
Dept. II-T1, Chicago 7, Illinois



NEW STEREO SONY STEREO TAPE DECK

Now, for less than the cost of a good record changer, you can add a versatile new dimension to your hi fi system. ■ The Sony 262-D tape deck has a 4 track stereo erase head and 4 track stereo record/playback head. Heads are wired to six output and input facilities for connection of external electronics to play and record four track stereo. This is the same quality mechanism used in the most expensive Sony Superscope tape recorders.

\$89⁵⁰

Other tape recorders in the remarkable Sony line include the dual track bantam at \$99.50, the Sterecorder 300, a complete portable stereo portable stereo system at only \$399.50, and the 262-SL parallel and sound-on-sound recorder at \$199.50. ■ For literature or nearest dealer, write: Superscope, Inc., Dept. T, Sun Valley, Calif.

SONY SUPERSCOPE The tapeway to Stereo

THERE'S BIG MONEY in Sound Equipment

here's how YOU can get it!



● A concise, readable, practical guide . . . important "do's" and "don'ts" based on the author's long experience in the field. Can pay back its low cost in minutes.

Some of the many topics: "Best Use of Sales Time," "Logical Sales Approaches," "Sound Advertising Techniques," "Sales Training & Merchandising Programs," plus Detailed Application Series on Airports, Schools, Churches, Offices . . . many others.

Order your copy today . . . for better business tomorrow.

ONLY **\$3.00** No C.O.D.'s Check with order please

SOUND Publishing Co., Inc.
299 Madison Avenue, New York 17.

REAL BARGAINS

Excellent broadcast range Crystal Radio Set, and miniature earphone with clip, both for 3.00. Earphone only. 1.50 Government surplus gold plated Crystal Diode Rectifiers, same as in above set, 7 for 1.00 Crystal Set kit only with assembly instructions 1.00. 50 assorted machine screws, nuts, washers 1.00. Tested Selenium Rectifiers, 4 plates (full wave units) with diagram; 300 mil. 40; 500 mil. 60; 1 amp 1.00; 3 amp 2.50. 100 watt 60 cycle, 8 contact Vibrators (replaceable 6 volt coil); change AC to DC or reverse; instructive diagrams, 2.25. 12 vdc experimental relay armatures 3 for 1.00. GE 12/24 vdc SPST Relays, 65; GE, adjustable 8-21 vdc 50 amp SPST relays, 2.00, 3 for 5.00. Struthers-Dunn latching Relays, 18/48 vdc (operates on Ac also), 2.00, 3 for 5.00. Leach 24 vdc DPDT Keying Relays, heavy contacts, 2.00, 3 for 5.00. Western Elec adjustable 6 to 24 vdc Relays, SPDT 2500 volt insulation, SPST holding contacts, 2.00, 3 for 5.00. All items prepaid USA. Discounts to schools and club groups.

SELETRONICS, The Plains, Ohio

Please mention **RADIO-ELECTRONICS** when answering advertisements

ENGINEERING DEGREE IN SCIENCE MATH 27 or 36 MOS.

Accelerated year-round program prepares for early employment in fields of Science and Engineering. Regular 4-year program for B.S. Degree completed in 36 months. Special engineering degree program in 27. Classes start January, March, June, July, September. Quality education. Graduates employed from coast to coast. Government approved for veteran training. Students from 50 states, 40 countries. 20 buildings; dorms, gym, Campus. Save time and money. Earn board while studying. Write for catalog and complete information. 1711 E. Washington Boulevard, Fort Wayne 2, Indiana

INDIANA TECHNICAL COLLEGE

Maximum ratings of this RCA tube:

	CCS	ICAS
V _p	250	250
V _{G2} (dc)	200	200
V _{G1} (dc)	-100	-100
I _p (dc) (ma)	90	100
I _{G1} (dc) (ma)	6	8
I _k (ma)	100	120
Plate input (watts)	12	14
G2 input (watts)	3	3.5
G1 input (watt)	0.2	0.24
P _p (watts)	6	7.5

2N1529-A, 30-A, 31-A, 32-A

A group of p-n-p germanium power transistors for industrial applications. These Motorola units can handle up to

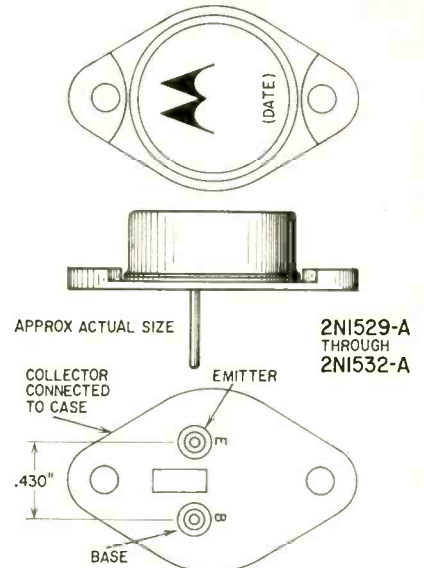

90 watts at voltages up to 100 with ease.

Absolute maximum ratings at 25° C are:

	2N1529-A	30-A	31-A	32-A
V _{CE}	20	30	40	50
V _{CB}	40	60	80	100
V _{EB}	20	30	40	50
I _c (continuous) (amp)	5	5	5	5
(peak) (amp)	10	10	10	10
P _c (watts)	90	90	90	90
h _{FE} (current gain)	40	40	40	40
g _{FE} (transconductance) (mhos) (minimum)	1.2	1.2	1.2	1.2

Epitaxial mesa transistors

A new family of germanium mesa transistors which take maximum advantage of the characteristics and potential of semiconductor materials. Epitaxial transistors consist of thin semiconductor layers epitaxially (derived from the Greek "setting on") deposited on low-resistivity substrates of germanium. The performance of epitaxial units, including saturation voltage, switching speed and collector capacitance, is far superior to conventional germanium mesa transistors.

This process is being used by Sylvania to produce two new transistors, types SYL2300 and SYL2301 (available in production quantities soon). As an example of the advantages of these new devices, the following statement was released by Sylvania: For equivalent transistor dimensions, saturation voltage at a 50-ma collector current is reduced by a factor of 3.5 and typical switching storage times are reduced by a factor of four. END

new PATENTS

CRYSTAL-CONTROLLED FM

Patent No. 2,945,192

Antoni Szymanski, Los Angeles, Calif. (Assigned to Standard Coil Products Co., Inc., Melrose Park, Ill.)

The ferrite element is a ferrite bar whose length is varied by magnetism. A coil around the bar carries audio from a microphone. Thus the bar applies pressure against a quartz crystal in

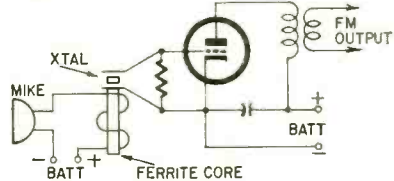

accordance with the strength of the audio signal.

The crystal controls the frequency of an oscillator. When no audio is present, the crystal dimension is such that the oscillator is on the desired center frequency. The signal changes the effective thickness of the crystal and thus modulates the frequency above and below the average value.

UNITY-GAIN AMPLIFIER

Patent No. 2,950,443

Gareth M. Davidson, New York, N. Y., and Robert F. Brady, Ridgefield, N. J. (Assigned to American Bosch Armco Corp.)

Among important advantages of a cathode follower, are its isolation characteristics, low

output impedance and low input capacitance. As is known, the output voltage of a follower is generally a few percent below its input.

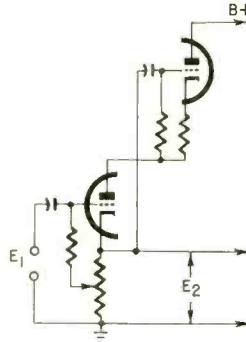

Sometimes it is desired that the output follow more closely the input voltage. Here two followers are used in cascade. Mathematical analysis shows that under this condition the expected output voltage (E_2) is only a few tenths of a percent below the input (E_1).

COMPENSATION OF PARALLEL TRANSISTORS

Patent No. 2,941,154

Samuel C. Rogers, Morristown, N. J. (Assigned to Bell Telephone Labs. Inc., New York)

It is unlikely that two transistors, even of the same type, will have similar characteristics.

all new edition

up-to-date component prices

PLUS

the quick easy way to figure service charges

EQUALS



Pure Riee's

OFFICIAL PRICING DIGEST

VOL. 4, NO. 1



Flat rate and hourly service charges, based on and showing regional and national averages, plus up-to-date list or resale prices on over 63,000 components. Arranged alphabetically by manufacturers and products, numerically by part number. Compact, convenient size fits in tube caddy, toolbox or pocket. \$2.50 per copy from your distributor.

ELECTRONIC PUBLISHING COMPANY, INC.
180 N. WACKER DRIVE, CHICAGO 6, ILL.

"ONE DOLLAR BUYS"

As Much as \$15 worth—Everything Brand New and sold to you with a money back guarantee. Pick - ANY 1 DOLLAR BUY FREE with every 10 you buy. FREE GIFT - with every Order of \$5.00 or over.

HANDY WAY TO ORDER—Simply tear out advertisement and pencil mark items wanted, enclose with money order or check. (Dot in square sufficient). You will receive a new copy of this ad for re-orders. ON SMALL ORDERS—Include stamps for postage, excess will be refunded. Larger orders shipped express collect.

- | | | |
|------------------------------------------------------------------------------------------------------------------------------------------------------------------------------------------------------------------------------------------------------------------------------------------------------------------------------------------------------------------------------------------------------------------------------------------------------------------------------------------------------------------------------------------------------------------------------------------------------------------------------------------------------------------------------------------------------------------------------------------------------------------------------------------------------------------------------------------------------------------------------------------------------------------------------------------------------------------------------------------------------------------------------------------------------------------------------------------------------------------------------------------------------------------------------------------------------------------------------------------------------------------------------------------------------------------------------------------------------------------------------------------------------------------------------------------------------------------------------------------------------------------------------------------------------------------------------------------------------------------------------------------------------------------------------------------------------------------------------------------------------------------------------------------------------------------------------------------------------------------------------------------------------------------------------------------------------------------------------------------------------------------------------------------------------------------------------------------------------------------------------------------------------------------------------------------------------------------------------------------------------------------------------------------------------------------------------------------------------------------------------------------------------------------------------------------------------------------------------------------------------------------------------------------------------------------------------------------------------------------------------------------------------------------------------------------------------------------------------------------------------------------------------------------------------------------------------------------------------------------------------------------------------------------------------------------------------------------------------------------------------------------------------------------------------------------------------------------------------------------------------------------------------------------------------------------------------------------------------------------------------------------------------------------------------------------------------------------------------------------------------------------------------------------------------------------------------------------------------------------------------------------------------------------------------------------------------------------------------------------------------------------------------------------------------------------------------------------------------------------------------|-------------------------------------------------------------------------------------------------------------------------------------------------------------------------------------------------------------------------------------------------------------------------------------------------------------------------------------------------------------------------------------------------------------------------------------------------------------------------------------------------------------------------------------------------------------------------------------------------------------------------------------------------------------------------------------------------------------------------------------------------------------------------------------------------------------------------------------------------------------------------------------------------------------------------------------------------------------------------------------------------------------------------------------------------------------------------------------------------------------------------------------------------------------------------------------------------------------------------------------------------------------------------------------------------------------------------------------------------------------------------------------------------------------------------------------------------------------------------------------------------------------------------------------------------------------------------------------------------------------------------------------------------------------------------------------------------------------------------------------------------------------------------------------------------------------------------------------------------------------------------------------------------------------------------------------------------------------------------------------------------------------------------------------------------------------------------------------------------------------------------------------------------------------------------------------------------------------------------------------------------------------------------------------------------------------------------------------------------------------------------------------------------------------------------------------------------------------------------------------------------------------------------------------------------------------------------------------------------------------------------------------------------------------------------------------------------------------------------------------------------------------------------------------------------------------------------------------------------------------------------------------------------------------------------------------------------------------------------------------------------------------------------------------------------------------------------------------------------------------------------------------------------------------------------------------------------------------------------------------------------------------------------------------------------------------------------------------------------------------------------------------------------------------------------------------------------------------------------------------------------------------------------------------------------------------------------------------------------------------------------------------------------------------------------------------------------------------------------------------------------------------------------------------------------------------------------------------------------------------------------------------------------------------------------------------------------------------------------------------------------------------------|-------------------------------------------------------------------------------------------------------------------------------------------------------------------------------------------------------------------------------------------------------------------------------------------------------------------------------------------------------------------------------------------------------------------------------------------------------------------------------------------------------------------------------------------------------------------------------------------------------------------------------------------------------------------------------------------------------------------------------------------------------------------------------------------------------------------------------------------------------------------------------------------------------------------------------------------------------------------------------------------------------------------------------------------------------------------------------------------------------------------------------------------------------------------------------------------------------------------------------------------------------------------------------------------------------------------------------------------------------------------------------------------------------------------------------------------------------------------------------------------------------------------------------------------------------------------------------------------------------------------------------------------------------------------------------------------------------------------------------------------------------------------------------------------------------------------------------------------------------------------------------------------------------------------------------------------------------------------------------------------------------------------------------------------------------------------------------------------------------------------------------------------------------------------------------------------------------------------------------------------------------------------------------------------------------------------------------------------------------------------------------------------------------------------------------------------------------------------------------------------------------------------------------------------------------------------------------------------------------------------------------------------------------------------------------------------------------------------------------------------------------------------------------------------------------------------------------------------------------------------------------------------------------------------------------------------------------------------------------------------------------------------------------------------------------------------------------------------------------------------------------------------------------------------------------------------------------------------------------------------------------------------------------------------------------------------------------------------------------------------------------------------------------------------------------------------------------------------------------------------------------------------------------------------------------------------------------------------------------------------------------------------------------------------------------------------------------------------------------------------------------------------------------------------------------------------------------------------------------------------------------------------------------|
| <ul style="list-style-type: none"> <input type="checkbox"/> 10 - TOP NAME #1U4 TUBES also serves as 1T4 . . . \$1 <input type="checkbox"/> 3 - #6AL5 unbranded, perfect . . . \$1 <input type="checkbox"/> 2 - TOP NAME #6SQ7 TUBES . . . \$1 <input type="checkbox"/> 2 - GENERAL ELECTRIC TUBES #35W4 . . . \$1 TOP NAME TUBES OZ4, 1B3, 1X2B, 5U4, 6AC7, 6AX4, 6CB6, 6J6, 6K6, 6U8, 6V6, 6SN7, 6X8, 12AU7, 12AX7, 50L6 . . . Each \$1 <input type="checkbox"/> 1 - ELECTRIC PHONO MOTOR 78 rpm, comp. \$1 <input type="checkbox"/> 12 - RADIO OSCILLATOR COILS 456 kc . . . \$1 <input type="checkbox"/> 1 - LB. SPOOL ROSIN CORE SOLDER . . . \$1 <input type="checkbox"/> 4 - 50' SPOOLS HOOK-UP WIRE 4 colors . . . \$1 <input type="checkbox"/> 10 - 6' ELECTRIC LINE CORDS with plugs . . . \$1 <input type="checkbox"/> 5 - TV CHEATER CORDS with both plugs . . . \$1 <input type="checkbox"/> 5 - TV CRT. SOCKETS with 18" leads . . . \$1 <input type="checkbox"/> 5 - HI-VOLT. ANODE LEADS with 18" leads . . . \$1 <input type="checkbox"/> 100' - TWIN LEAD-IN WIRE 300Ω heavy duty \$1 <input type="checkbox"/> 50' - FLAT 4-CONDUCT. WIRE many purposes \$1 <input type="checkbox"/> 25' - INSULATED SHIELDED WIRE . . . \$1 <input type="checkbox"/> 32' - TEST PROD WIRE deluxe (red or black) . . . \$1 <input type="checkbox"/> 1 - \$7 INDOOR TV ANTENNA hi-gain 3 section \$1 <input type="checkbox"/> 20 - ASST. TV KNOBS, ESCUTCHEONS, Etc. \$1 <input type="checkbox"/> 1 - RCA 70° FLYBACK TRANS. #75240 . . . \$1 <input type="checkbox"/> 1 - FLYBACK TRANS. 90° w/schematic . . . \$1 <input type="checkbox"/> 1 - TV VERT. OUTPUT TRANS. 10 to 1 ratio . . . \$1 <input type="checkbox"/> 1 - TV VERT. BLOCKING TRANS. standard . . . \$1 <input type="checkbox"/> 15 - ASST. TV COILS some peaking, with etc. \$1 <input type="checkbox"/> 15 - ASST. STANDARD TUNER VHF STRIPS \$1 <input type="checkbox"/> 6 - ASST. STANDARD TUNER UHF STRIPS \$1 <input type="checkbox"/> 2 - SILICON RECTIFIERS 500ma . . . \$1 <input type="checkbox"/> 1 - SILICON RECTIFIER 750ma . . . \$1 <input type="checkbox"/> 25 - ASST. PEAKING COILS popular types \$1 <input type="checkbox"/> 10 - TV CARTWHEEL CONDENSERS 10kv . . . \$1 <input type="checkbox"/> 3 - TV CARTWHEEL CONDENSERS 20kv . . . \$1 <input type="checkbox"/> 2 - TV CARTWHEEL CONDENSERS 30kv . . . \$1 <input type="checkbox"/> 1 - TV RATIO DETECTOR COIL 4.5mc . . . \$1 <input type="checkbox"/> 1 - TV RATIO DETECTOR COIL 10.7mc . . . \$1 <input type="checkbox"/> 1 - TV SOUND I.F. COIL 4.5mc . . . \$1 <input type="checkbox"/> 1 - TV FOCUS COIL 270, 330 or 470 ohms . . . \$1 <input type="checkbox"/> 3 - HV RECTIFIER SOCKETS 1B3 m'ted . . . \$1 <input type="checkbox"/> 3 - HV RECTIFIER SOCKETS 1X2 m'ted . . . \$1 <input type="checkbox"/> 1 - TV SYNCHROGUIDE COIL #205R1 . . . \$1 #15 - "JACKPOT" TELEVISION PARTS . . . \$1 <input type="checkbox"/> 3 - TV ALIGNMENT TOOLS assortment #1 . . . \$1 <input type="checkbox"/> 3 - TV ALIGNMENT TOOLS assortment #2 . . . \$1 <input type="checkbox"/> 3 - TV ALIGNMENT TOOLS assortment #3 . . . \$1 <input type="checkbox"/> 3 - TV ALIGNMENT TOOLS assortment #4 . . . \$1 <input type="checkbox"/> 3 - TV ALIGNMENT TOOLS assortment #5 . . . \$1 | <ul style="list-style-type: none"> <input type="checkbox"/> 4 - AUDIO OUTPUT TRANS. 50L6 type . . . \$1 <input type="checkbox"/> 1 - 5" PM SPEAKER alnico #5 magnet . . . \$1 <input type="checkbox"/> 1 - 4" PM SPEAKER alnico #5 magnet . . . \$1 <input type="checkbox"/> 1 - 3 1/2" PM SPEAKER alnico #5 magnet . . . \$1 <input type="checkbox"/> 1 - 3 1/2" TWEETER SPEAKER for HI-FI . . . \$1 <input type="checkbox"/> 3 - AUDIO OUTPUT TRANS. 6K6 or 6V6 type \$1 <input type="checkbox"/> 3 - I.F. COIL TRANSFORMERS 456 kc . . . \$1 <input type="checkbox"/> 3 - I.F. COIL TRANSFORMERS 10.7 mc. FM \$1 <input type="checkbox"/> 3 - I.F. COIL TRANSFORMERS 262 kc (auto) . . . \$1 <input type="checkbox"/> 40 - ASST. PRECISION RESISTORS best sizes . . . \$1 <input type="checkbox"/> 100 - MICA CONDENSERS 820 mmf . . . \$1 <input type="checkbox"/> 5 - SELENIUM RECTIFIERS 65ma 11st \$1.50 ea \$1 <input type="checkbox"/> 4 - SELENIUM RECTIFIERS 75ma . . . \$1 <input type="checkbox"/> 3 - SELENIUM RECTIFIERS 250ma . . . \$1 <input type="checkbox"/> 2 - SELENIUM RECTIFIERS 300ma . . . \$1 <input type="checkbox"/> 2 - SELENIUM RECTIFIERS 1-350ma 1-75ma \$1 <input type="checkbox"/> 1 - SELENIUM RECTIFIER 500 ma . . . \$1 <input type="checkbox"/> 3 - ASST. SIZES RADIO CHASSIS PANS . . . \$1 <input type="checkbox"/> 3 - VARIABLE CONDENSERS super 420/162mmf \$1 <input type="checkbox"/> 50 - STRIPS ASST. SPAGHETTI best sizes \$1 <input type="checkbox"/> 100 - ASST. RUBBER GROMMETS best sizes \$1 <input type="checkbox"/> 4 - OVAL LOOP ANTENNAS asst hi-gain types \$1 <input type="checkbox"/> 3 - LOOPSTICK ANT. new ferrite adjustable . . . \$1 <input type="checkbox"/> 3 - 1/2 MEG VOLUME CONTROLS with switch \$1 <input type="checkbox"/> 5 - ASST. 4 WATT WIREWOUND CONTROLSS1 <input type="checkbox"/> 5 - 1/2 MEG VOLUME CONTROLS less switch \$1 <input type="checkbox"/> 5 - 1 or 2 MEG VOLUME CONTROLS \$1/switch \$1 <input type="checkbox"/> 100 - VOLUME CONTROL HEX NUTS . . . \$1 <input type="checkbox"/> 10 - SURE GRIP ALLIGATOR CLIPS . . . \$1 <input type="checkbox"/> 1 - GOLD GRILLE CLOTH 14" x 14" or 12" x 18" . . . \$1 <input type="checkbox"/> 5 - SETS SPEAKER PLUGS wired . . . \$1 <input type="checkbox"/> 10 - SETS PHONO PLUGS and PIN JACKS \$1 <input type="checkbox"/> 2 - \$2.50 SAPPHIRE NEEDLES 4000 playings \$1 <input type="checkbox"/> 3 - ELECTROLYTIC CONDENSERS 80-400v . . . \$1 <input type="checkbox"/> 35 - MICA COND. 20-50 mmf & 15-68 mmf . . . \$1 <input type="checkbox"/> 35 - MICA COND. 20-100 mmf & 15-270 mmf . . . \$1 <input type="checkbox"/> 35 - MICA COND. 20-470 mmf & 15-680 mmf . . . \$1 <input type="checkbox"/> 35 - MICA COND. 20-820 mmf & 15-1000 mmf . . . \$1 <input type="checkbox"/> 35 - MICA COND. 20-2200 mmf & 15-2400 mmf . . . \$1 <input type="checkbox"/> 35 - MICA COND. 20-6800 mmf & 15-10000 mmf . . . \$1 <input type="checkbox"/> 35 - CERAMIC COND. 20-5 mmf & 15-10 mmf . . . \$1 <input type="checkbox"/> 35 - CERAMIC COND. 20-25 mmf & 15-47 mmf . . . \$1 <input type="checkbox"/> 35 - CERAMIC COND. 20-56 mmf & 15-82 mmf . . . \$1 <input type="checkbox"/> 35 - CERAMIC COND. 20-100 mmf & 15-150 mmf . . . \$1 <input type="checkbox"/> 35 - CERAMIC COND. 20-270 mmf & 15-470 mmf . . . \$1 <input type="checkbox"/> 35 - CERAMIC COND. 20-1000 mmf & 15-1500 mmf \$1 <input type="checkbox"/> 35 - CERAMIC COND. 20-2000 mmf & 15-5000 mmf \$1 | <ul style="list-style-type: none"> <input type="checkbox"/> 10 - DIODE CRYSTALS 1N34A . . . \$1 <input type="checkbox"/> 100 - ASST. CERAMIC CONDENSERS . . . \$1 <input type="checkbox"/> 100 - ASST. 1/2 WATT RESISTORS some 5% . . . \$1 <input type="checkbox"/> 70 - ASSORTED 1 WATT RESISTORS . . . \$1 <input type="checkbox"/> 35 - ASSORTED 2 WATT RESISTORS . . . \$1 <input type="checkbox"/> 50 - ASST. TUBULAR CONDENSERS . . . \$1 <input type="checkbox"/> 50 - CONDENSERS .01-500v . . . \$1 <input type="checkbox"/> 50 - ASSORTED FUSES popular sizes . . . \$1 <input type="checkbox"/> 50 - 100Ω 1/2 WATT RESISTORS 10% . . . \$1 <input type="checkbox"/> 75 - 470KΩ 1/2 WATT RESISTORS 10% . . . \$1 <input type="checkbox"/> 5 - DIODE CRYSTALS 1N60 . . . \$1 <input type="checkbox"/> 100 - 5AG FUSES 2 amp 1 1/2" x 3/8" . . . \$1 <input type="checkbox"/> 100 - 5AG FUSES 20 amp 1 1/2" x 3/8" . . . \$1 <input type="checkbox"/> 100 - 5AG FUSES (50.2 amp & 50.20 amp) . . . \$1 <input type="checkbox"/> 300 - ASST. 1/2 WATT RESISTORS short leads . . . \$1 <input type="checkbox"/> 5 - DIODE CRYSTALS 1N64 . . . \$1 <input type="checkbox"/> 5 - DIODE CRYSTALS 1N69 . . . \$1 <input type="checkbox"/> 10 - ASST. WIREWIND RES. 5, 10, 20 watt . . . \$1 <input type="checkbox"/> 10 - HV TUBULAR CONDENSERS .008-1600v . . . \$1 <input type="checkbox"/> 35 - ASST. DISC CERAMICS best numbers . . . \$1 <input type="checkbox"/> 50 - ASST. MICA CONDENSERS some in 5% . . . \$1 <input type="checkbox"/> 6 - ASST. SLIDE SWITCHES spst, dpdt, etc. \$1 <input type="checkbox"/> 3 - ASST. TOGGLE SWITCHES spst, dpdt, etc \$1 <input type="checkbox"/> 15 - ASST. ROTARY SWITCHES \$15 worth . . . \$1 <input type="checkbox"/> 100' - FINEST NYLON DIAL CORD best size . . . \$1 <input type="checkbox"/> 200 - SELF TAPPING SCREWS #8 x 1/2" . . . \$1 <input type="checkbox"/> 35 - ASST. RADIO KNOBS screw and push-on . . . \$1 <input type="checkbox"/> 100 - ASSORTED KNOB SET-SCREWS . . . \$1 <input type="checkbox"/> 25 - ASSORTED CLOCK RADIO KNOBS . . . \$1 <input type="checkbox"/> 35 - ASST. SOCKETS octal, novol and miniature . . . \$1 <input type="checkbox"/> 25 - ASST. PRINTED CIRCUIT SOCKETS . . . \$1 <input type="checkbox"/> 10 - ASST. VOLUME CONTROLS less switch . . . \$1 <input type="checkbox"/> 5 - ASST. VOLUME CONTROLS with switch . . . \$1 <input type="checkbox"/> 20 - ASST. PILOT LIGHTS popular types . . . \$1 <input type="checkbox"/> 10 - PILOT LIGHT SKTS. bayonet type, wired . . . \$1 <input type="checkbox"/> 50 - ASST. TERMINAL STRIPS 1, 2, 3, 4 lug . . . \$1 <input type="checkbox"/> 10 - ASST. RADIO ELECTRO. CONDENSERS \$1 <input type="checkbox"/> 5 - ASST. TV ELECTROLYTIC CONDENSERS \$1 <input type="checkbox"/> 15 - TUBULAR CONDENSERS .1-600v . . . \$1 <input type="checkbox"/> 15 - TUBULAR CONDENSERS .047-600v . . . \$1 <input type="checkbox"/> 15 - TUBULAR CONDENSERS .47-400v . . . \$1 <input type="checkbox"/> 2 - ELECTROLYTIC COND. 40/40-450v . . . \$1 <input type="checkbox"/> 3 - ELECTROLYTIC COND. 50/30-150v . . . \$1 <input type="checkbox"/> 35 - DISC. CERAMIC CONDENSERS 5000mmf \$1 <input type="checkbox"/> 25 - ASST. RADIO DIAL POINTERS . . . \$1 <input type="checkbox"/> 600 - ASST. H'DWARE screws, nuts, rivets, etc \$1 <input type="checkbox"/> 8 - ASST. LUCITE CASES handy for parts . . . \$1 |
|------------------------------------------------------------------------------------------------------------------------------------------------------------------------------------------------------------------------------------------------------------------------------------------------------------------------------------------------------------------------------------------------------------------------------------------------------------------------------------------------------------------------------------------------------------------------------------------------------------------------------------------------------------------------------------------------------------------------------------------------------------------------------------------------------------------------------------------------------------------------------------------------------------------------------------------------------------------------------------------------------------------------------------------------------------------------------------------------------------------------------------------------------------------------------------------------------------------------------------------------------------------------------------------------------------------------------------------------------------------------------------------------------------------------------------------------------------------------------------------------------------------------------------------------------------------------------------------------------------------------------------------------------------------------------------------------------------------------------------------------------------------------------------------------------------------------------------------------------------------------------------------------------------------------------------------------------------------------------------------------------------------------------------------------------------------------------------------------------------------------------------------------------------------------------------------------------------------------------------------------------------------------------------------------------------------------------------------------------------------------------------------------------------------------------------------------------------------------------------------------------------------------------------------------------------------------------------------------------------------------------------------------------------------------------------------------------------------------------------------------------------------------------------------------------------------------------------------------------------------------------------------------------------------------------------------------------------------------------------------------------------------------------------------------------------------------------------------------------------------------------------------------------------------------------------------------------------------------------------------------------------------------------------------------------------------------------------------------------------------------------------------------------------------------------------------------------------------------------------------------------------------------------------------------------------------------------------------------------------------------------------------------------------------------------------------------------------------------------------------------------|-------------------------------------------------------------------------------------------------------------------------------------------------------------------------------------------------------------------------------------------------------------------------------------------------------------------------------------------------------------------------------------------------------------------------------------------------------------------------------------------------------------------------------------------------------------------------------------------------------------------------------------------------------------------------------------------------------------------------------------------------------------------------------------------------------------------------------------------------------------------------------------------------------------------------------------------------------------------------------------------------------------------------------------------------------------------------------------------------------------------------------------------------------------------------------------------------------------------------------------------------------------------------------------------------------------------------------------------------------------------------------------------------------------------------------------------------------------------------------------------------------------------------------------------------------------------------------------------------------------------------------------------------------------------------------------------------------------------------------------------------------------------------------------------------------------------------------------------------------------------------------------------------------------------------------------------------------------------------------------------------------------------------------------------------------------------------------------------------------------------------------------------------------------------------------------------------------------------------------------------------------------------------------------------------------------------------------------------------------------------------------------------------------------------------------------------------------------------------------------------------------------------------------------------------------------------------------------------------------------------------------------------------------------------------------------------------------------------------------------------------------------------------------------------------------------------------------------------------------------------------------------------------------------------------------------------------------------------------------------------------------------------------------------------------------------------------------------------------------------------------------------------------------------------------------------------------------------------------------------------------------------------------------------------------------------------------------------------------------------------------------------------------------------------------------------------------------------------------------------------------------------------------------------------------------------------------------------------------------------------------------------------------------------------------------------------------------------------------------------------------------------------------------------------------------------------------------------------------------------------------------------------------------------------------------------------------------------------------------------------------------------------|-------------------------------------------------------------------------------------------------------------------------------------------------------------------------------------------------------------------------------------------------------------------------------------------------------------------------------------------------------------------------------------------------------------------------------------------------------------------------------------------------------------------------------------------------------------------------------------------------------------------------------------------------------------------------------------------------------------------------------------------------------------------------------------------------------------------------------------------------------------------------------------------------------------------------------------------------------------------------------------------------------------------------------------------------------------------------------------------------------------------------------------------------------------------------------------------------------------------------------------------------------------------------------------------------------------------------------------------------------------------------------------------------------------------------------------------------------------------------------------------------------------------------------------------------------------------------------------------------------------------------------------------------------------------------------------------------------------------------------------------------------------------------------------------------------------------------------------------------------------------------------------------------------------------------------------------------------------------------------------------------------------------------------------------------------------------------------------------------------------------------------------------------------------------------------------------------------------------------------------------------------------------------------------------------------------------------------------------------------------------------------------------------------------------------------------------------------------------------------------------------------------------------------------------------------------------------------------------------------------------------------------------------------------------------------------------------------------------------------------------------------------------------------------------------------------------------------------------------------------------------------------------------------------------------------------------------------------------------------------------------------------------------------------------------------------------------------------------------------------------------------------------------------------------------------------------------------------------------------------------------------------------------------------------------------------------------------------------------------------------------------------------------------------------------------------------------------------------------------------------------------------------------------------------------------------------------------------------------------------------------------------------------------------------------------------------------------------------------------------------------------------------------------------------------------------------------------------------------------------------------------------------------------|

BROOKS RADIO & TV CORP., 84 Vesey St., Dept. A, New York 7, N. Y. TELEPHONE COrtland 7-2359

ANOTHER Mercury SERVICE AID

Can be used with your VTVM, SCOPE or SIGNAL TRACER

Save the cost of 4 separate probes!

See your electronics parts distributor

The versatile MULTI-PROBE Patent Pending
DOES THE WORK OF 4 PROBES!

DC Probe

AC/Ohms Probe

RF Probe

Lo-Cap Probe



Model MP-1 \$975
MULTI-PROBE Net

Now for the first time — exclusive with MERCURY — a MULTI-PROBE that does all the work of 4 different probes. Functions: DC position . . . matches VTVM input impedance • AC/Ohms position . . . for all low frequency, low impedance, voltages and wave forms • RF position . . . a demodulator for checking RF voltages, wave forms and signals and TV/radio RF and IF stages • Lo-Capacity position . . . a must for high impedance, TV sync and radio circuits where regular probes overload the circuit.

MERCURY ELECTRONICS CORP.,

77 SEARING AVENUE, MINEOLA, NEW YORK
West Coast Office: 4306 W. Victory Blvd., Burbank, Calif.

SILENT SERVICE

with

QUIETROLE



SPRAY IT OR DROP IT



the first, the quality, the proved silencing "Lubri-Cleaner" for noisy controls and switches on TV, radio and electronic instruments. SPRAY IT or DROP IT . . . it's easy—efficient—effective. Make QUIETROLE your silent partner in providing satisfactory service.

manufactured by

QUIETROLE Company
SPARTANBURG, South Carolina

In Canada: CROSS CANADA ELECTRONICS
12 Laurel St., Waterloo, Ont.



New Volume III

SURPLUS RADIO CONVERSION MANUAL

—gives new conversion data, instructions, and diagrams for putting surplus equipment to practical use.

Contents include:

701-A; AN/APN-1; AN/CRC-7; AN/URC-4; ARA: BC-442, 453-455, 456-459, 603, 696, 950, 1066, 1253; CBY-29125, 50083, 50141, 52208-11, 52232, 52302-09; FT-241A; MBF (COL-43065); MD-7/ARC-5; R-9/APN-4; R23-R28/ARC-5; RAT; RAV; RM-52(53); RT-19/ARC-4; SCR-274N; SCR-522; T-15/ARC-5 to T-23/ARC-5.

For list of contents of Vols. I and II, send stamped, addressed envelope. \$2.50 per volume

at your distributor, or add 10% on orders to



EDITORS and ENGINEERS, Ltd.

Summerland 5, California

Bookstores: order from Baker & Taylor, Hillside, N.J.

LOWEST PRICED ELECTRONIC ASSORTMENTS IN AMERICA!

RADIO-TV PARTS BY THE POUND IN NEW... JUMBO PAKS!

SPECIAL TRUCK-LOADS

of manufacturers over-runs at a fraction of their original cost!

ONE POUND PRECISION RESISTORS
WORTH \$100

ONE POUND DISC CONDENSERS
WORTH \$50

ONE POUND CERAMIC CONDENSERS
WORTH \$85

ONE POUND DISCS & CERAMICS
WORTH \$75

ONE POUND Discs, Ceramics PRECISIONS
WORTH \$70

BUY 4 PAKS for \$11.00

\$3⁰⁰ per pound

Clip out & mail



FREE GIANT BARGAIN CATALOG WRITE FOR YOURS!

HOW TO ORDER: Include check or M.O. with sufficient postage; excess returned. C.O.D. orders, 25% down; rated, net 30 days. INCLUDE POSTAL ZONE in address.

LEKTRON

241 Everett Ave.
CHELSEA 50, MASS.

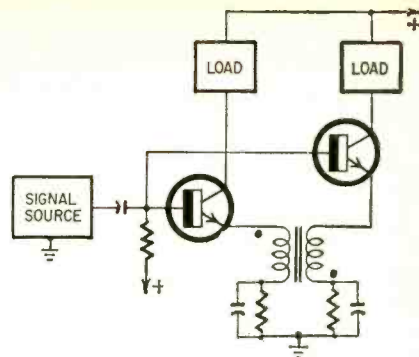

When connected in parallel, one usually takes more than its share of power, leading to early breakdown. The circuit shows a distribution amplifier with equal loads in the collector circuits and a 1:1 ratio transformer (T) to compensate for transistor inequality. If one transistor passes more current through its winding than the other does, power is transferred to the other winding. This drives the weaker transistor to a greater extent and equalizes the load.

Here is an example of two dissimilar transistors, A and B, which were tested as follows:

Transistor	Alpha	Coll. volts without T	Coll. volts with T
A	.994	2.25	1.49
B	.957	1.25	1.42

TRIGGERED THYRATRON

Patent No. 2,942,160

James B. Ricketts, Jr., Bryn Maur, and Robt. H. Schafer, Upper Darby, Pa. (Assigned to Burroughs Corp., Detroit, Mich.)

Pulses can fire a thyatron if they last long enough. This circuit can be triggered by pulses as short as 1.5 μ sec. The pulses are stepped up

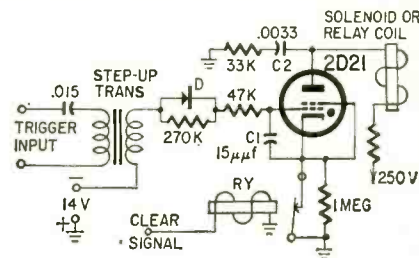

and polarized so that positive pulses of about 50 volts are applied to the grid.

The short pulses pass through D and charge C1. This maintains the positive potential at the grid for a longer time than pulse duration.

Normally, the tube is cold and C2 is charged to the full 250 volts. After ignition, C2 discharges through the tube and "keeps it alive" until tube current through the inductive load (relay coil) rises enough to sustain conduction.

To reset the circuit, relay RY is energized. This connects the 1-megohm resistor in the cathode return and de-ionizes the tube. END

50 Years Ago

In Gernsback Publications

HUGO GERNSBACK, Founder

Modern Electrics	1908
Wireless Association of America	1908
Electrical Experimenter	1913
Radio News	1919
Science & Invention	1920
Television	1927
Radio-Craft	1929
Short-Wave Craft	1930
Television News	1931

Some larger libraries still have copies of Modern Electrics on file for interested readers.

In January, 1911, Modern Electrics

Demonstration of Wireless Telephony, by Dr. Erich F. Huth (Berlin).
Unique Wireless Submarine Installation, by Frank C. Perkins.
Unique Radiophone Arc.
New Loose Coupler.
Wireless on Department Store (Wanamaker's).
Construction of a 50-Watt Laboratory Transformer, by Charles F. Frassa, Jr.
An Audible Detector, by C. A. Pettingill.
Unique Variable Condenser.
Simple Detector, by Edward De Mello.
Improved Photometer, by A. C. Marlowe.
Effect of Winter Upon Wireless Wave Propagation, by George F. Worts.

Special: All About Kits That Teach Electronics

DECEMBER • 35 CENTS

ELECTRONICS ILLUSTRATED

By the Publishers of MECHANIX ILLUSTRATED

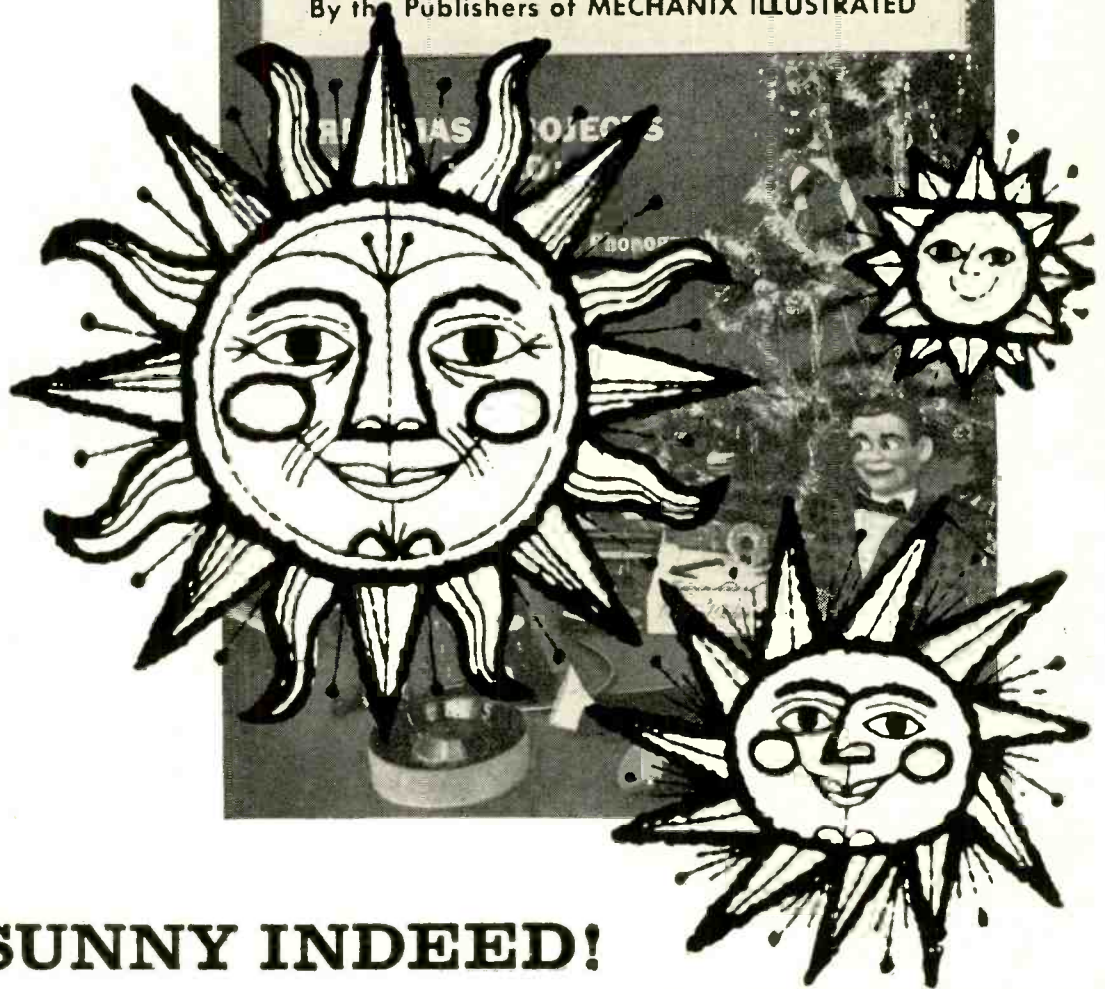

VERY SUNNY INDEED!

Things have never been brighter at **ELECTRONICS ILLUSTRATED**. / Monthly circulation has soared to an all-time high guarantee of 175,000—but 200,000 is forecasted. / The reason: elementary. A more graphic, “how to” editorial format that is right as rain for active electronics enthusiasts... and one that *attracts new prospects, brings new life to the electronics market*. / Your selling picture clouded? There’s a silver lining. Advertise in **ELECTRONICS ILLUSTRATED** and watch sales brighten!

ELECTRONICS ILLUSTRATED

A Fawcett Publication

New York • Chicago • Detroit • Los Angeles • San Francisco • Miami • Atlanta

JANUARY, 1961

113

Now—24-Hour Tuner Service

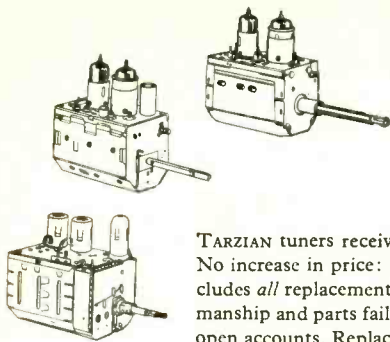

**Tarzian Offers 24-hour
Direct Factory Service
on TUNER REPAIRS
... \$8.50**

TARZIAN tuners received one day will be repaired and shipped out the next. No increase in price: \$8.50 per unit and \$15 for UV combinations. That includes all replacement parts, and a 6-month warranty against defective workmanship and parts failure due to normal usage. Tuners repaired on approved, open accounts. Replacements available at low cost on tuners beyond practical repair.

Tarzian-made tuners easily identified by this stamping. When inquiring about service on other than Tarzian-made tuners, always give tube complement . . . shaft length . . . filament voltage . . . series or shunt heater . . . IF frequency . . . chassis identification. And, allow a little more time for service on these tuners. Use this address for fast, factory repair service:

SERVICE MANAGER • TUNER DIVISION Dept. C



SARKES TARZIAN INC

east hillside drive
bloomington, indiana
edison 2-7251

Mfgs. of Tuners, Semiconductors, Air Trimmers, FM Radios, Audio Tape, and Broadcast Equipment



Model 103
TUBE TESTER

CHECKS ALL RADIO
AND TV TUBES FOR:

- ✓ Cathode emission
- ✓ Shorts and leakage
- ✓ Grid leakage
- ✓ Gas content

Model 103
TUBE TESTER

\$4775
Net

SPOTS HARD-TO-FIND TUBE DEFECTS IN JUST SECONDS!



Although low in price the Model 103 has a range of operation that will outperform more expensive tube testers.

Here's how easy it is to test all tubes completely, accurately—IN JUST SECONDS!

- 1 SET 3 CONTROLS
- 2 INSERT TUBE
- 3 PRESS QUALITY BUTTON

- Tests picture tubes with a specially designed built-in CRT socket
- Positively cannot become obsolete . . . circuitry is engineered to accommodate all new tube types
- New tube charts furnished periodically to registered owners

See your electronics parts distributor

MERCURY ELECTRONICS CORP. 77 SEARING AVENUE, MINEOLA, NEW YORK

STAMP OF APPROVAL



A mail-order tube advertisement in RADIO-ELECTRONICS is its own stamp of approval—your assurance that you will get what you pay for when you order. Since January, 1956, RADIO-ELECTRONICS has insisted that mail-order tube advertisers tell you that their tubes are new and unused, or, if they're not—that they are seconds, rejects or otherwise imperfect. Over the years this has cost us thousands of dollars in advertising—but it has protected you.

**FREE Catalog Of The WORLD'S
FINEST GOV'T
SURPLUS ELECTRONIC BARGAINS**

MAGNAVOX AUDIO AMPLIFIER

• Mfg'd for the Navy for intercommunication and amplification of radio signals. Uses 2/12A6 tubes in push-pull; also high quality input transformer for carbon microphone, and receiver input-output transformer has variable control for headset or speaker. Also mounting for 12 Volt Dynamotor, and instruction book. Voltage required for operation 12 VDC and 250 VDC 60 MA. Can be used for mobile or home use. Size: 7 1/2 x 7 x 10". Wt.: 15 lbs. Navy #CMX-50128. Complete with 3/12A6 Tubes (1 spare), less Dynamotor. **\$2.95**

Address Dept. RE • All Prices F.O.B., Lima, Ohio
• 25% Deposit Required on C.O.D. Orders



Price—w/12 V. Dynamotor **\$6.95**

FAIR RADIO SALES
2133 ELIDA RD. • P.O. Box 1105 • LIMA, OHIO

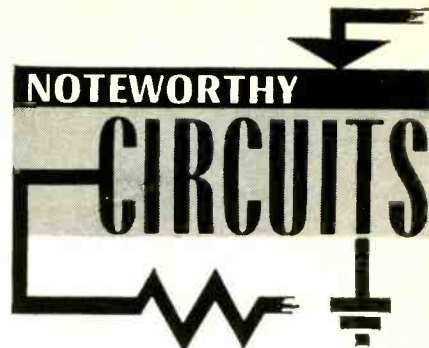

REGULATED DC HEATER SUPPLY

By combining Zener diodes and a standard power transistor we can get a low-ripple regulated dc heater supply. The circuit is very stable and provides good regulation despite line and load

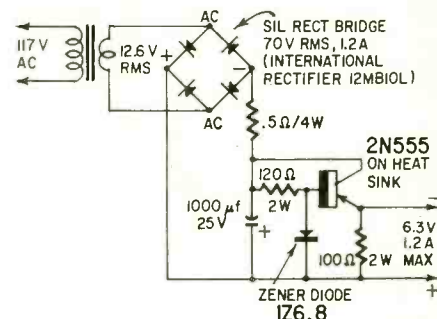

variations. Combining the Zeners with the power transistor gives us a degree of regulation and filtering that is often difficult to get at low voltages and high currents.—*International Rectifier News*

I-TRANSISTOR SNITCHER

I have been experimenting with a one-transistor transmitter that meets the same qualifications as the Snitcher described by Irvin Chapel in the November, 1959, issue. I use a 3-foot car

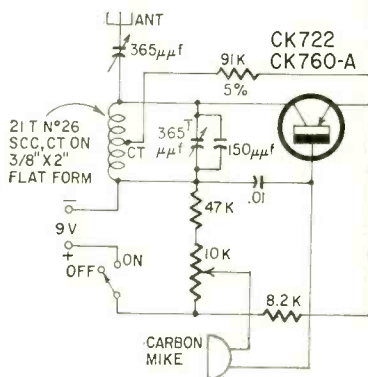

antenna, Eveready 216 battery and a single-button carbon mike. By using a 3/8 x 2-inch flat coil form and trimmers for tuning, all the parts fit on a small chassis.—*Steve Greenbaum*

TRANSISTOR GAIN CHECKER

The schematic shows a simple but accurate transistor gain checker set for low-power transistors. It is used with any vom or vtm and provides a direct-reading dial calibrated in beta gain from 5 to 100. In addition, it will determine

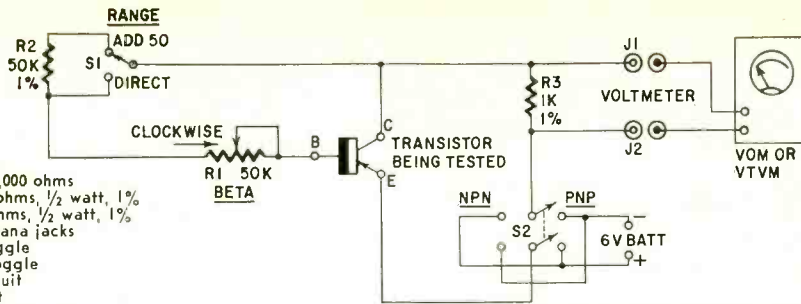

R1—pot, 50,000 ohms
 R2—50,000 ohms, 1/2 watt, 1%
 R3—1,000 ohms, 1/2 watt, 1%
 J1, J2—banana jacks
 S1—spst toggle
 S2—dpdt toggle
 Chassis to suit
 Case to suit
 Miscellaneous hardware

whether the transistor is shorted or open.

Mount R1 and its knob on the panel. Connect a good ohmmeter to the center and left-hand terminal (the end not tied to the slider) and scribe a mark on the panel opposite the knob setting every 5,000 ohms as the shaft is rotated clockwise. Label the first 5,000-ohm setting as 5, the next as 10, the next as 15 and so on until the 50,000-ohm value is reached and labeled 50. The rest of the wiring is straightforward.

To test a transistor for beta between 5 and 50, throw S1 to DIRECT and S2 to the proper transistor polarity. Increase or decrease R1's resistance until a voltmeter attached to J1 and J2 reads exactly 3 volts. Then read beta directly from R1's calibrated scale. For betas between 50 and 100, throw S1 to ADD 50, adjust R1 for exactly 3 volts on the voltmeter and the beta will be the dial reading plus 50.

If the transistor has a collector-to-

base or collector-to-emitter short, the voltmeter will read close to 6 volts and varying R1 will not produce any change in the meter reading. If the base is shorted to the emitter, little or no reading will be present on the meter. An open emitter or base results in no reading, and an open collector will result in little or no reading. If the transistor produces a reading above 3 volts on the DIRECT setting and cannot be reduced to 3 volts with R1, its beta is higher than 50 and S1 must be thrown to the ADD 50 setting.

The beta range can be extended by adding more 50,000-ohm resistors in series with R2 with appropriate switching. One 50,000-ohm resistor in addition to R2 will extend the range to 150 and two added will measure beta gain to 200. The basic direct dial reading is 50, and 50 more must be added for each added resistor. The 6-volt battery will last for some time but check it occasionally for aging. The accuracy of the tester will be affected if less than 6 volts is available.—Dave Stone END

BUILD YOUR OWN THEREMIN!



Now you can enjoy the ethereal, mysterious, fascinating sound of the THEREMIN. You play this most modern of musical instruments without touching it—simply by moving your hands about it. The THEREMIN has no keys, buttons or strings.

For the first time, a transistorized THEREMIN is available in kit form. This easy-to-build musical instrument is featured in the January, 1961, issue of *Electronics World* magazine. For a free reprint of this article and complete information on this exciting new kit, mail this coupon today.



R. A. MOOG CO.

Department C
 P.O. Box 263
 Ithaca, New York
 Please send me complete information on the build-it-yourself THEREMIN.
 Name _____
 Address _____
 City _____ Zone _____ State _____
 Please Print

Just Out

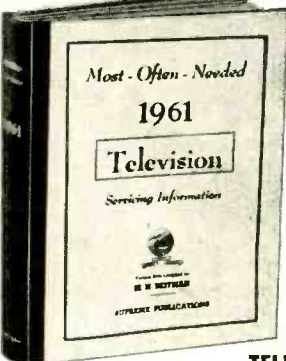

New SUPREME 1961 TV Manual

AMAZING BARGAIN

The new 1961 TV manual is the bargain of the year. Covers all important sets of every make in one giant volume. Your price for this mammoth manual is only \$3. This super-value defies all competition. Other annual volumes at only \$3 each. Factory service material simplifies repairs. Includes all data required for quicker TV servicing. Practically tells you how to find each fault and make needed repair. More pages, more diagrams, more service data per dollar of cost.

TELEVISION SERVICING COURSE

Let this new course help you in TV servicing. Amazing bargain, complete, only \$3, full price for all lessons. Giant in size, mammoth in scope, topics just like a \$200.00 correspondence course. Lessons on picture faults, circuits, adjustments, short-cuts, UHF, alignment facts, hints, antenna problems, picture analysis. Special, only **\$3**

SIMPLIFIED RADIO SERVICING (Introduction to TV)

Explains how to use comparison method to find most radio faults in minutes. Many practical tests without any equipment. Also several sections on use of instruments, Introduction to TV. Schematics, charts, service hints. Job sheets cover all sets. New edition. Only **\$1.50**

RADIO VOLUMES

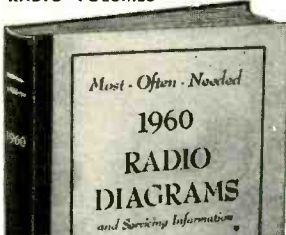

RADIO DIAGRAMS

SUPREME is your best source for all needed RADIO diagrams and service data. Covers everything from the most recent 1960 radios to pre-war old-timers; home radios, stereo, combinations, transistor portables, FM, and auto sets. Sensational values. Only \$2 for many volumes. Every manual has extra large schematics, all needed alignment facts, printed boards, voltage values, trimmers, dial stringing, and helpful hints. Volumes are large in size, 8 1/2 x 11 inches, about 190 pages. See coupon at right for a complete list of these popular radio service manuals. →

COVERS ALL POPULAR SETS

Here is your service data for faster, easier TV repairs. Lowest priced. Best by comparison. *Supreme TV* manuals have all needed service material on every popular TV set. Helpful, practical, factory-prepared data that will really make TV servicing easy for you. Benefit and save with these amazing values in service manuals. Only \$3 per large, yearly volume.



SIMPLIFIES TV REPAIRS

These giant TV manuals have complete circuits, needed alignment facts, printed boards, servicing hints, production changes, voltage charts, waveforms, and double-page schematics. Here are your authentic service instructions to help you do expert work quicker; and priced at only \$3 per large annual manual. Repair any TV model ever made by having in your shop all 15 volumes as listed in coupon. Your special price for all, only \$40. Or try the new 1961 TV manual to see what an amazing bargain you get for \$3. Send no-risk trial coupon today.

The repair of any television set is really simple with *Supreme TV* service manuals. Every set is covered in a practical manner that will simplify trouble-shooting and repair. This is the help you need to find toughest faults in a jiffy. Most \$3 TV volumes cover a whole year of service material. New *Television Servicing Course* will aid you in learning TV. Be wise, buy *Supreme Manuals* only once each year instead of spending dollars every week.

NO-RISK TRIAL ORDER COUPON

SUPREME PUBLICATIONS,

1760 Balsam Rd., Highland Park, Ill.

- 1960
- 1959
- 1958
- 1957
- 1956
- 1955
- 1954
- 1953
- 1952
- 1951
- 1950
- 1949
- 1948
- 1947
- 1946
- 1942
- 1941
- 1940
- 1924-1938 Manual, \$2.50
- Simplified Servicing, \$1.50

Popular RADIO Diagram Manuals at only **\$2.50** each.....

1955 Radio Manual, only \$2
 These annual RADIO volumes specially priced at only **\$2.50** each.....

THIS GROUP ONLY
\$2 EACH
 Name: _____
 Address: _____

Rush today TV manuals checked below and Radio manuals at left. Satisfaction guaranteed.
 New 1961 TV Manual, \$3. 1960 TV, \$3.
 Additional 1959 TV, \$3. Early 1959 TV, \$3.
 1958 TV Manual, \$3. Additional 1957 TV, \$3.
 Early 1957 TV, \$3. 1956 TV Manual, \$3.
 Additional 1955 TV, \$3. Early 1955 TV, \$3.
 1954 TV, \$3. 1953 TV, \$3. 1952 TV, \$3.
 1951 TV, \$3. 1957-58 RCA TV Manual, \$1.50
 New *Television Servicing Course*, complete... \$3.

I am enclosing \$..... Send postpaid.
 Send C.O.D. I am enclosing \$..... deposit.

Supreme Publications
 Sold by All Leading Parts Jobbers

**First . . . Basics of Digital Computers
 . . . and now
 BASICS OF ANALOG COMPUTERS**

by Thos. D. Truitt (Director of Advanced Study Group, ELECTRONIC ASSOC., INC.)
 & A. E. Rogers (Senior Consultant, ELECTRONIC ASSOC., INC.)

Anyone having the slightest knowledge of engineering or physics will derive great benefit from this remarkable "pictured-text" course (3 volumes in one cloth binding). If you are a practicing engineer, you will be made familiar with the analog computer—with the suitability of this device for your design needs—and with the programming requirements. If you are a training director responsible for training maintenance technicians, or a teacher in a college or a technical institute, you will find this an effective "pictured-text" course that is easy to use. If you are a computer maintenance technician who is ambitious, you can gain a familiarity with this advanced computing technology. If you are an engineering college student looking toward a computerized technology, you can easily acquire a thorough understanding of the analog computer. More than 400 illustrations reinforce the ideas discussed in the text to make it completely understandable.

Beginning with the simple idea of learning by experimentation, it progresses through the basic types of analog devices, introduces the reader slowly to the mathematical concepts involved, explains in detail the workings of modern general-purpose electrical analog computers and rounds out the course by presenting worthwhile practical applications of the computer.

VOLUME I includes descriptions of many kinds of analog computers and devices including: INTRODUCTION TO ANALOGS (what is an analog? analogs and physical laws; problem solving with analogs); WHY ANALOG? (analog charac-

teristics, analog devices vs. analog computers; analog computers vs. digital computers); COMPUTER BUILDING BLOCKS (building blocks, multipliers, function generators) MATHEMATICS OF COMPUTING (variables, integration, differentiation, differential equations, integrators).

VOLUME II gives detailed attention to the computer that is most flexible and easy to use—the D-C Electronic differential analyzer. It includes: GENERAL PURPOSE COMPUTER TYPES (passive-element computers, active element computers); D-C ANALOG COMPUTER: LINEAR COMPUTING COMPONENTS (attenuators, voltage amplifiers, the summing amplifier, the integrating amplifier); D-C ANALOG COMPUTER MULTIPLYING COMPONENTS (the servomultiplier, the electronic multipliers, implicit uses of multipliers); D-C ANALOG COMPUTER FUNCTION GENERATION (fixed function generators, variable function generators).

VOLUME III presents some of the programming techniques and interesting applications common to the field of analog computation. It includes: MONITORING AND CONTROL (voltmeters, recorders and plotters); PROGRAMMING AND PROBLEMS (using the D-C analog computer, automatic programming); APPLICATIONS (real time simulation, real time joint analog-digital simulation).

Questions and problems are included at the end of each section to enable you to check your progress. #256-H, 3 vols. in one cloth binding, \$12.50.

BASICS OF DIGITAL COMPUTERS ('Pictured-Text' Course) John S. Murphy. Basic theory of computer arithmetic, circuitry, logical building blocks and memory. JOURNAL OF THE ASSOCIATION FOR COMPUTING MACHINERY "... the 'picture book' form is extremely effective. The text itself is terse and to the point, and supplemented as it is by pic-

tures on each page turns out to be easy to read and understand. There are no obvious compromises with accuracy of statement for ease of presentation. For the purpose it was written, the book does a very good job; and even for coders who would like to know more about how the machines really work, it is worth reading." 3 vols., #196, soft, \$8.40; #196-H, cloth, \$9.50.

These and many other Rider titles are available at bookstores, electronic parts distributors, dept. stores or direct. Send for new catalog. Buy these books today—No matter where you buy these books, we guarantee satisfaction, or your money back within 30 days of purchase.

JOHN F. RIDER PUBLISHER, INC., 116 West 14th Street, New York 11, N. Y.
 Canada: Chas. W. Pointon, Ltd., 66 Racine Rd., Rexdale, Ont.
 Export: Acme Code Company, Inc., 630 9th Ave., N. Y. C.
 India: Asia Publishing House, Bombay and other cities

**ANOTHER
 Mercury
 SERVICE AID**

CONVERT YOUR TUBE TESTER INTO A HIGHLY EFFICIENT PICTURE TUBE TESTER...



The MULTI-HEAD incorporates:

- 12-pin socket—for all standard base black and white tubes
- 8-pin socket—for all 110 degree narrow-neck RCA type tubes
- 7-pin socket—for all 110 degree narrow-neck Philco and Sylvania type tubes
- 14-pin socket—for all color TV tubes in use today
- Color gun switch—for checking the red, green and blue color guns separately

See your electronics parts distributor

No other CRT Adapter does as much as the MULTI-HEAD!

- ✓ TEST ALL BLACK AND WHITE PICTURE TUBES
- ✓ TEST ALL COLOR PICTURE TUBES

Model MH-1 \$12.45 Net
 MULTI-HEAD

MERCURY ELECTRONICS CORP., 77 SEARING AVENUE, MINEOLA, NEW YORK
 West Coast Office: 4306 W. Victory Blvd., Burbank, Calif.



DANGER—HIGH-VOLTAGE

While high-voltage indicator lamps are useful, one is apt to get used to seeing them lit and make the wrong move anyway. A blinker lamp will do a much better job of keeping one's subconscious informed that lethal high voltage is on. A very simple neon-lamp blinker can be made and installed in less than ½ hour using only one capac-

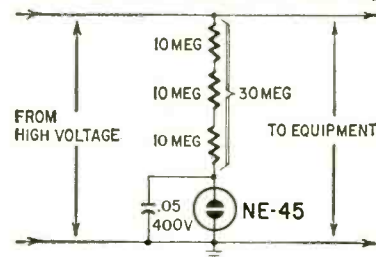

itor, three resistors and a ¼-watt neon lamp.

The value of resistance shown is about right for a 1,250-volt supply and produces about one blink per second. This resistance must be adjusted according to the voltage of the power supply being used and the desired blink rate.

If the neon light glows steadily, the resistance is too low. Use a clear-glass jewel.—Arnaldo Coro, Jr.

NEW "MAGIC ANTENNA"

Some owners of portable television sets, or any larger sets with rabbit-ear antennas, will find a greatly increased signal by doing the following:

Plug your set into a heavy-duty extension cord rather than directly into a wall outlet and loop the extension cord around one of the antenna poles as illustrated. Be sure to use a heavy-duty extension cord. Ordinary household cords do not give a boost to reception.

Before doing this, I could only pick up two channels, but now I pull in five,

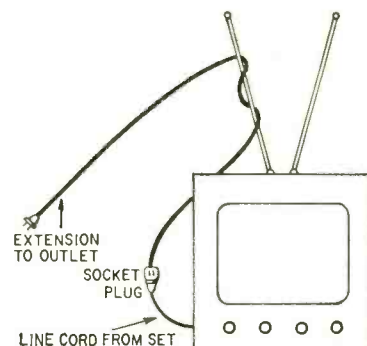

including a very clear and highly satisfactory image from one channel which, in the past, didn't even show up faintly.—*Lawrence Bunker*

GUN CARRIES OWN SANDER

When soldering, a little sandpaper or other form of abrasive is often needed for cleaning wire tips, lugs, etc. A small square of sandpaper taped to

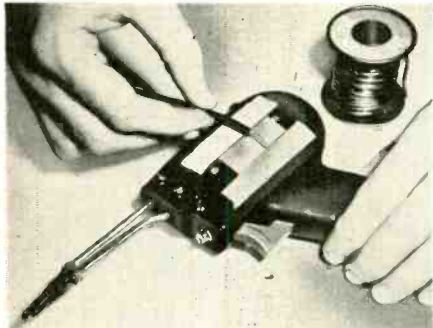

the side of your soldering gun can save you much wasted time and needless steps hunting up sandpaper when in the midst of a soldering job. Tape a piece to your gun now, before you forget!—*John A. Comstock*

SCREWDRIVER MODIFICATION

When working on electronics gear, you sometimes encounter screws in out-of-reach places accessible only to an

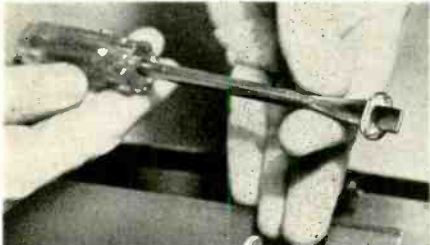

offset screwdriver. You will always have an offset driver handy if you convert a regular screwdriver by soldering a metal washer to the blade near the tip as shown. File two edges of the washer flat like the tip of a screwdriver.—*Scott Mock*

THUMB SCREW WRENCH

An effective tool to tighten or loosen thumbscrews quickly can be made from a discarded socket wrench. For this purpose a cheap socket is preferred

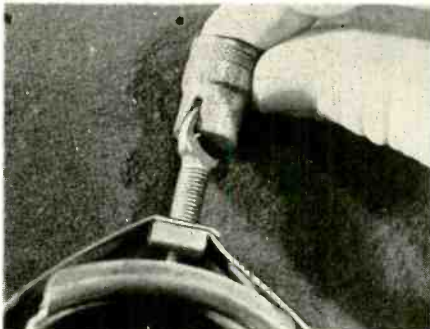

since it is made of soft steel which can be readily cut. Saw a rather deep, wide slot in the socket and it can be used with a socket-wrench speed handle. It will save a lot of time and turning effort.—*Glen F. Stillwell* END

TOP
SILICON

HAT
RECTIFIER

FROM 250 MA TO 6-12-18 & 35 AMP
FACTORY DIRECT. Exclusive Distributors for Name Brand. Immediate Delivery. All Types

750 MA. RECTIFIERS GUAR.
Input Working Range RMS/ACV Res. or Cap.

PIV/RMS 50/35 .15 ea.	PIV/RMS 100/70 .25 ea.	PIV/RMS 200/140 .30 ea.	PIV/RMS 300/210 .40 ea.
PIV/RMS 400/280 .45 ea.	PIV/RMS 500/350 .65 ea.	PIV/RMS 600/420 .75 ea.	PIV/RMS 700/490 .90 ea.
PIV/RMS 800/560 .95 ea.	PIV/RMS 900/630 1.15 ea.	PIV/RMS 1000/700 1.55 ea.	PIV/RMS 1100/770 1.75 ea.

SPECIAL!!! All Purpose Rectifier 400 piv @ 250ma .35 ea. 25 for 7.50

DISTRIBUTORS—OEM—EXPORTERS
WRITE QTY PRICES

- SPECIALS: 100 Different Pres. Res. 1/2W, 1W-2W 1/2%, 1% Tol. Only \$1.70/c NEW
- 100ma Selenium Rectifiers @ .39 NEW
- 100 ASST. RADIO & TV KNOBS Push-ons \$1.00 NEW

All Material Guaranteed. \$2.00 min. order. Orders F.O.B. NYC. Include check or money order. Shpg charges plus. C.O.D. orders 25% down.

WARREN DIST. CO.
NYC 7, NY 89 Chamber St. WO 2-5727

FREE! CATALOG OF
HI-FI, RADIO, TV
PARTS & ACCESSORIES —
yours for the asking!

Vidair ELECTRONICS MFG. CORP.
365 BABYLON TPKE. — ROOSEVELT, N. Y.

OUT OF SPACE?
You bet we'd be... if we were to tell you all about AUDION's 'Out of this World Hi Fi Values'.

Write for free Catalog

audi-on

25-E Oxford Road
Massapequa, New York

FREE!

RADIO SHACK'S famous Electronics CATALOGS

for 12 full months

See over 100,000 items like these

- Stereo, hi-fi
- LP records
- New hi-fi kits
- New tester kits
- Recorded tapes
- Accessory tools
- Electronic parts

★

Yes! Mail coupon for 12 months of savings on electronic equipment! Finest quality, tremendous selection! Easiest terms—up to 2 years to pay. Satisfaction guaranteed.

RADIO SHACK Corp.
730 Commonwealth Ave., Boston 17, Mass.

RADIO SHACK CORP. Dept. 61A10
730 Commonwealth Ave., Boston 17, Mass.

Please send me Radio Shack's catalogs for next 12 months FREE and POSTPAID.

Name _____

Address _____

City _____ Zone _____ State _____

Results?—You will get them with classified ads in Radio-Electronics only 50c a word.

See R-E classified ads page 119

ELECTRONICS

Engineering-Technicians

Bachelor of Science Degree, 30 Months
Save Two Years' Time

- Radio-Television Plus Color Technician (12 Months)
- Electronics Technician (12 Months)
- Industrial Electronics Technician (12 Months)
- Electronics Engineering (B.S. Degree)
- Electrical Engineering (B.S. Degree)
- Mechanical Engineering (B.S. Degree)
- Civil Engineering (B.S. Degree)
- Architecture (B.S. Degree)

Heald College ranks FIRST West of the Mississippi in "Who's Who in America"

Approved for Veterans
DAY AND EVENING CLASSES
Write for Catalog and Registration Application.
New Term Starting Soon.

Your Name _____

Address _____

City _____

State _____

HEALD'S

ENGINEERING COLLEGE

Established 1863

Van Ness at Post, RE
San Francisco, Calif.

Missile headed for outer space. Courtesy of Space Technology Laboratories, Inc.

U.S. Air Force Photo

Television RADIO-ELECTRONICS Electricity ELECTRONICS IN NEW SHOP-LABS OF COYNE

TRAIN QUICKLY! OLDEST, BEST EQUIPPED SCHOOL of ITS KIND in U.S.

Get practical training in New Shop-Labs of Coyne. Prepare for a better job and a successful future in a top opportunity field. Advanced education or previous experience not needed. Employment service to graduates.

Enroll NOW—Pay Later

Finance Plan and Easy Payment Plan. Also Part Time Employment help for students.

FREE BOOK Clip coupon or write to address below for Free Illustrated Book. "Guide to Careers"—Describes all training offered. No obligation and No Salesman Will Call. Act NOW.

B. W. Cooke, Jr., President

**CHARTERED
NOT FOR PROFIT
ESTABLISHED 1899
1501 W. Congress Pkwy.,
Chicago, Dept. 11-5C**

**COYNE Electrical School
1501 W. Congress Pkwy., Chicago 7, Ill.
Dept. 11-5C**

Send FREE book "Guide to Careers" and details of all training you offer. However, I am especially interested in:

ELECTRICITY TELEVISION BOTH FIELDS

NAME.....

ADDRESS.....

CITY.....STATE.....

BUSINESS and PEOPLE

B&K Manufacturing Co., Chicago, announced a new tube information service covering data on new tube types as they are produced by manufacturers. The service, which includes complete tube charts twice a year, will be issued every 3 months to owners of B&K tube testers on an annual subscription or individual copy basis.

Astatic Corp., Conneaut, Ohio, developed a simplified system for stocking its needle line. The new Asta-Stock system includes custom-designed cabinets,

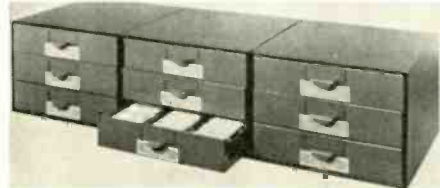

individual packages for each needle and complete cross-reference information as part of each needle package and on index tabs of the stock cabinet.

Shure Bros., Inc., Evanston, Ill., designed a new hang-tag for phonographs equipped with its Standard Stereo Dynetic phono cartridges to help hi-fi and radio appliance dealers promote phonograph sales.



National Technical Schools, Los Angeles, has 14 Afro-Asian students enrolled under the US Government's Non-Quota Student Act. William Inkumah, son of the Minister of State for Interior of the Republic of Ghana, was recently



graduated from the school after completing an 18-month course in electronics. He is shown (left) with Dr. L. J. Rosenkranz, president of National Schools.

NEW YORK • WORLD CENTER FOR RADIO-ELECTRONICS • 1961

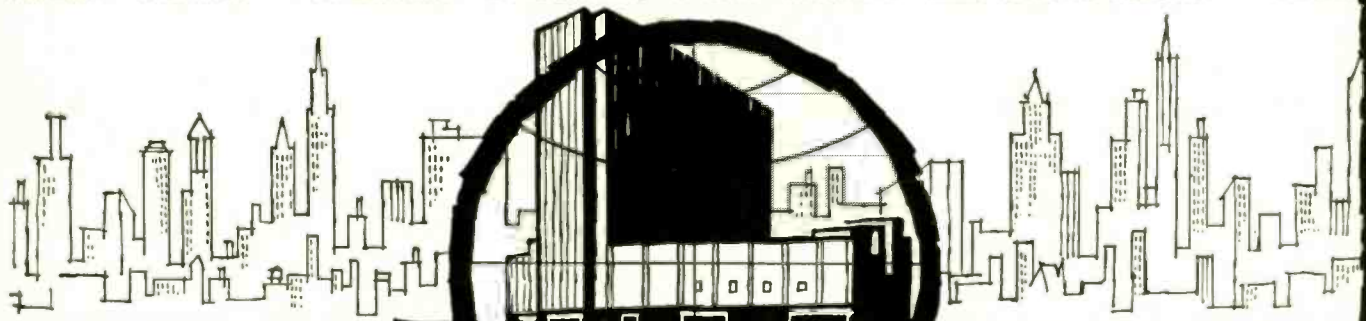

INTERNATIONAL **IRE SHOW** CONVENTION

Visitors from all over the world will converge on the Coliseum, March 20-23, for IRE's big Show and International Convention. Join the more than 65,000 radio-electronics engineers who will attend! On the Coliseum's 4 gigantic floors you'll see the latest production items, systems, instruments and components in radio-electronics; in radar; in complex air traffic control; in space communications—in any and

every field of radio-engineering you care to name. At the convention, you'll trade ideas with brilliant delegates from the world of radio-electronics, and choose from amongst scores of papers to be read by experts in their field. Like the IRE show, the convention is both a summing-up and a look into the future! *Remember the occasion, the time, the place.*



Registration: IRE members \$1.00—non-members \$3.00

MARCH 20-23 1961

INTERNATIONAL CONVENTION and IRE SHOW



The Institute of Radio Engineers
1 East 79th St., New York 21, N. Y.

WALDORF-ASTORIA HOTEL
COLISEUM • NEW YORK
No one under 18 years of age will be admitted.

RCA Electron Tube Div., Harrison, N. J., marked the 25th anniversary of its tube handbook. To commemorate the event, E. C. Hughes Jr., manager, commercial engineering (right), presented the initial five-binder set of the new



handbook *HB-3* to D. Y. Smith, vice president and general manager of the division. R. S. Burnap, consultant to the Electron Tube Div., who introduced the first handbook in 1935, holds the first single-binder edition.

Krylon, Inc., Norristown, Pa., presented its 1960 Award for Outstanding Sales Achievement to the Newhope Corp., New York City. Lee Rocke, Newhope president, is shown holding the



award as Richard C. Newbold, Krylon vice president, sales; Elmore E. Kayser, Krylon vice president, advertising and promotion; James W. Bampton, Krylon president; Tom Marchiano, Newhope vice president; Bernie Tonn and Bob Fitterman of the Newhope sales staff look on (left to right).

Clarence H. Hopper was appointed president of CBS Electronics, Danvers, Mass. He had been vice president—facilities, CBS, for the past 5 years. He succeeds Arthur L. Chapman who joined the headquarters staff of CBS in New York.



Glenn E. Ronk (left) was promoted to general sales director of Cornell-Dubilier Electronics Div., Federal Pacific Electric Co., South Plainfield, N. J. He was formerly industrial and military sales manager. He joined the company in 1959 after 7 years with American Electronics, Inc. Rear Admiral Carl F. Stillman, USN (Ret), was appointed



administrative assistant to the vice president, marketing. Since his return from the Navy in 1957, he has been engaged in various capacities in the military electronics industry for such

R-E

Classified

ADS

Rates—50¢ per word (including name, address and initials. Minimum ad 10 words. Cash must accompany all ads except those placed by accredited agencies. Discount, 10% for 12 consecutive issues. Misleading or objectionable ads not accepted. Copy for March issue must reach us before January 10, 1961.

RADIO-ELECTRONICS, 154 West 14 St., New York 11, N. Y.

RADIO & TV TUBES at Manufacturers' Prices! 100% Guaranteed! Brand New! No re-brands or pulls! UNITED RADIO, Box 1000-R, Newark, N. J.

FIRE ALARMS FOR HOMES AND SHOPS. \$9.25 ppd., additional heat detector \$1.25 each; special quotation to jobbers and distributors. KAMCO-ELECTROCHEM CO., 2712 N. Magnolia, Chicago 14, Ill.

BOOKS—ALL 10¢, 2000 titles, all subjects, catalog free. COSMAO, Clayton, Ga.

NEW, TRANSISTORIZED SIGNAL GENERATOR. 150 KC. to 120 MC. on fundamentals. Battery operated. Internal 400 cycle, any external audio modulation. Socket for Citizens Band Crystals. Send for free information. PEL ELECTRONICS, Box 555, Ridgewood, N. J.

NEW CONCEPT OF LEARNING SELF-HYPNOSIS! Now on tape or record! Free Literature. MCKINLEY-SMITH CO., Dept. T5, Box 3038, San Bernardino, Calif.

TRANSISTOR RADIO SPECIALIST—to the Trade—\$4 Plus Parts—ECUADORIAN ELECTRONICS, 1621 Amsterdam Avenue, New York 31, N. Y.

LEARN WHILE ASLEEP, Hypnotize with your recorder, phonograph or amazing new Electronic Educator endless tape recorder. Catalog, details free. SLEEP-LEARNING ASSOCIATION, Box 24-RD, Olympia, Wash.

ALL MAKES OF ELECTRICAL INSTRUMENTS AND TESTING equipment repaired. New and used instruments bought, sold, exchanged. HAZELTON INSTRUMENT CO., 128 Liberty Street, New York, N. Y.

DISCOUNTS UP TO 50% on Hi-Fi amplifiers, tuners, speakers, tape recorders, individual quotations only, no catalogs. CLASSIFIED HI-FI EXCHANGE, 2375 East 65th Street, Brooklyn 34, N. Y.

TRANSISTOR AND TUBE POCKET RADIOS. Rejects. Original List \$29.00 to \$39.00. \$5.95—3 for \$14.95. Sold as is. MYERS, 623 Gay, Knoxville, Tenn.

COMPONENTS, Recorders, Tapes. FREE Wholesale Catalogue. CARSTON, 215-T East 88th St., New York 28, N. Y.

AMPEX, Concertone, Crown, Magnecord, Presto, Norelco, Bogen, Tandberg, Sherwood, Rek-O-Kut, Scott, Shure, Dynakit, others . . . Trades. BOYNTON STUDIO, Dept. RE, 10 Pennsylvania Ave., Tuckahoe, N. Y.

HI-FI DOCTOR will solve your hi-fi problems on the spot. Acoustic, Audio, Radio Engineer. Stereo Designing. Professional visits, day, evening. New York area. WILLIAM BOHN, Plaza 7-8569, weekdays.

CASH PAID! Sell your surplus electronic tubes. Want unused, clean radio and TV receiving, transmitting, special purpose, Magnetrons, Klystrons, broadcast types, etc. Want military & commercial lab/test and communications equipment such as G.R., H.P., AN/UPM prefix. Also want commercial receivers and transmitters. For a fair deal write BARRY, 512 Broadway, New York 12, N. Y. WALKER 5-7000.

QUALITY PRINTING. Economically priced. Speedy service. Free samples on request. JOHN H. TAYLOR, R. D. 2, Box 215, West Middlesex, Pa.

DIAGRAMS FOR REPAIRING RADIOS, television \$2. Give make and Model. DIAGRAM SERVICE, Box 672 RE, Hartford 1, Conn.

"THIRTY MILLION BOOKS IN STOCK"—Latest selective catalog of Government Publications, including Electrical Engineering, Atomic Science, Astronautics—\$3.70; free details about other educational opportunities. AUREAX, Central Valley, N. Y.

MANUFACTURERS REPRESENTATIVE, 25 years Electronic Experience wants good lines—Metropolitan Area. J. JARETT, 2 Russet Lane, Wantagh, L. I., N. Y.

DON'T BUY HI-FI COMPONENTS, Kits, Tape, Tape Recorders until you get our low, low return mail quotes. "We Guarantee Not To Be Undersold." Wholesale Catalog Free. HI-FIDELITY CENTER, 1797RC First Avenue, New York 28, N. Y.



Model 800
CRT TESTER-REACTIVATOR

TESTS

- Emission • Inter-element leakage • Life expectancy . . . estimates the remaining life of picture tube

REPAIRS

- Inter-element shorts • Welds open elements

REACTIVATES

- Low emission tubes with a controlled high voltage pulse • Reactivation is seen and controlled on the meter

✓ TESTS ✓ REPAIRS ✓ REACTIVATES ALL BLACK and WHITE and ALL COLOR picture tubes



- ✓ Also accommodates the new 8-pin, 7-pin, and 14-pin base picture tubes

- ✓ Also provides the newer 2.35 and 8.4 filament voltages

- ✓ Tests the red, green and blue sections of color tubes separately

Model 800

\$49.95 Net

Housed in handsome wood carrying case.

See your electronics parts distributor!

MERCURY ELECTRONICS CORP. 77 SEARING AVENUE, MINEOLA, NEW YORK

which of these 4 NEW books will help you MOST?



The Story of Stereo: 1881
John Sunier
No. 98—160 pages. \$2.95

For the first time—the whole fascinating history of stereo from its earliest beginnings in the last century right up to today. Stereo applications on tape, film, discs and broadcasting—plus a consideration of stereo techniques in the home, in business, industry and medicine.



Practical TV Troubleshooting
No. 102—128 pages. \$2.35

Some of the best technician-writers in the business tell you how to handle intermittents, ghosts, horizontal oscillator troubles, foldover, jitter and many other common and uncommon tough ones. A compilation of the best on TV servicing from *Radio-Electronics Magazine*.



Practical Auto Radio Service & Installation
By Jack Greenfield
No. 87—160 pages. \$2.95

Shows you how to install and remove auto sets, rear seat speakers, troubleshoot and repair speakers, tuners, power supplies. Covers FM, hybrids, all-transistor sets, auto phonographs. This one will help you build your business, increase your earnings.

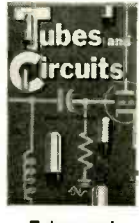

Tubes and Circuits
By George Christ
No. 82—192 pages. \$3.45

Considers basic electron theory, characteristics of simple and multiple element tubes, various tube types, gas tubes, photoelectric emission, and industrial applications. This book enables the technician to analyze circuit troubles intelligently and correct them quickly and efficiently through an understanding of fundamentals.

On sale at distributors now—or buy direct. Order all four books.

OTHER POPULAR GERNSBACK LIBRARY BOOKS

SERVICING

- No. 85—How to Get the Most Out of Your VOM \$2.90
- No. 81—Printed Circuits. \$2.90
- No. 78—Rapid Radio Repair. \$2.90
- No. 76—Servicing Transistor Radios. \$2.90
- No. 72—Oscilloscope Techniques. \$2.90
- No. 68—TV and Radio Tube Troubles. \$2.90
- No. 65—Servicing Color TV— \$2.90
- No. 60—Rapid TV Repair. \$2.90
- No. 59—Servicing Record Changers. \$2.90
- No. 57—The VTVM. \$2.50
- No. 55—Sweep and Marker Generators for TV and Radio— \$2.50

- No. 54—Probes. \$2.50
- No. 52—The Oscilloscope. \$2.25
- No. 49—Radio & TV Test Instruments. \$1.50
- SEMICONDUCTORS**
- No. 92—Fundamentals of Semiconductors— \$2.95
- No. 89—Transistor Projects. \$2.90
- No. 63—Transistor Circuits. \$2.75
- No. 61—Transistor Techniques. \$1.50
- No. 75—Transistors Theory & Practice. \$2.95
- HIGH FIDELITY**
- No. 90—Hi-Fi Made Easy. \$2.90
- No. 86—Installing Hi-Fi Systems. \$3.20
- No. 80—Stereo—How it Works. \$2.90
- No. 79—Designing and Building Hi-Fi Furniture. \$2.90

- No. 73—Audio Measurements. \$2.90
- No. 71—Audio Design Handbook. \$2.90
- No. 67—Elements of Tape Recorder Circuits. \$2.90
- No. 66—Basic Audio Course. \$2.75
- No. 64—Understanding Hi-Fi Circuits. \$2.90
- No. 58—Maintaining Hi-Fi Equipment. \$2.90
- No. 56—High-Fidelity Circuit Design. (Cloth Bound.) \$5.95
- No. 48—High Fidelity—Design, Construction, Measurements. \$1.50
- HOBBIES**
- No. 74—Model Radio-Control. \$2.65
- No. 70—Electronic Puzzles and Games. \$1.95
- No. 69—Electronic Hobbyists' Handbook. \$2.50

- No. 53—Radio-Control Handbook. \$2.25

FUNDAMENTALS—MISCELLANEOUS

- No. 84—Marine Radio for Pleasure Craft. \$2.95
 - No. 77—Guide to Mobile Radio. \$2.85
 - No. 62—TV—It's a Cinch. \$2.90
 - No. 47—Radio & TV Hints. \$1.00
 - No. 45—Radio Tube Fundamentals. \$1.00
- Books paper bound unless otherwise noted.

Books purchased for professional use are tax deductible

ON SALE AT YOUR DISTRIBUTOR — OR ORDER DIRECT

Gernsback Library, Inc., Dept. 11

154 West 14th St.
New York 11, N.Y.

Please send me the books checked postpaid. My remittance of \$_____ is enclosed.

Name _____ please print

Street _____

City _____ Zone _____ State _____

- | | | | | | |
|------------------------------|-----------------------------|-----------------------------|-----------------------------|-----------------------------|-----------------------------|
| <input type="checkbox"/> 102 | <input type="checkbox"/> 98 | <input type="checkbox"/> 92 | <input type="checkbox"/> 90 | <input type="checkbox"/> 89 | <input type="checkbox"/> 87 |
| <input type="checkbox"/> 86 | <input type="checkbox"/> 85 | <input type="checkbox"/> 84 | <input type="checkbox"/> 82 | <input type="checkbox"/> 81 | <input type="checkbox"/> 80 |
| <input type="checkbox"/> 79 | <input type="checkbox"/> 78 | <input type="checkbox"/> 77 | <input type="checkbox"/> 76 | <input type="checkbox"/> 75 | <input type="checkbox"/> 74 |
| <input type="checkbox"/> 73 | <input type="checkbox"/> 72 | <input type="checkbox"/> 71 | <input type="checkbox"/> 70 | <input type="checkbox"/> 69 | <input type="checkbox"/> 68 |
| <input type="checkbox"/> 67 | <input type="checkbox"/> 66 | <input type="checkbox"/> 65 | <input type="checkbox"/> 64 | <input type="checkbox"/> 63 | <input type="checkbox"/> 62 |
| <input type="checkbox"/> 61 | <input type="checkbox"/> 60 | <input type="checkbox"/> 59 | <input type="checkbox"/> 58 | <input type="checkbox"/> 57 | <input type="checkbox"/> 56 |
| <input type="checkbox"/> 55 | <input type="checkbox"/> 54 | <input type="checkbox"/> 53 | <input type="checkbox"/> 52 | <input type="checkbox"/> 49 | <input type="checkbox"/> 48 |
| <input type="checkbox"/> 47 | <input type="checkbox"/> 45 | | | | |

companies as Radiation Research Corp., General Instrument Corp. and Stavid Engineering, Inc.

J. B. Holtz was appointed marketing manager, new products, for Centralab, the electronics division of Globe-Union. He has been with the company for 18 years in various executive and administrative capacities.



Leroy E. Tice joined Simpson Electric Co., Chicago, as chief field engineer. He comes from Cook Electric Co., where he was staff engineer and section director.



Thornton S. Adams joined Allied Radio Corp., Chicago, as director of marketing. He had been a marketing consultant to Allied since June, 1959. He was formerly vice president in charge of sales for Spiegel Inc. and consultant to Sears Roebuck & Co. and Aldens, Inc.



Harry Turkington (left) was named director of engineering and Hal Moore chief meter engineer of the Meter and



Controls Div. of Hickok Electrical Instrument Co., Cleveland. Turkington was formerly chief engineer, product application, for Simpson Electric Co. and Moore a member of Hickok's meter engineering department since 1957.

John Hauser was promoted to general manager, distributor sales, of CBS Electronics, Danvers, Mass. He had been distributor sales manager, electron tubes. Roy Juusola, manager of marketing administration, was promoted to manager of marketing services. Lee Ballengee, manager of equipment sales, electron-tube operations, is now responsible for all government and military marketing in addition to his former duties. Ross Yeiter, assistant semiconductor sales manager, has been elevated to sales manager, semiconductors.

C. P. (Bill) Oliphant was promoted to managing editor of the Technical Book Div. of Howard W. Sams & Co., Inc., Indianapolis, Ind. He has been with the company for 8 years as assistant editor of *PF Reporter*.



new LITERATURE

Any or all of these catalogs, bulletins, or periodicals are available to you on request direct to the manufacturers, whose addresses are listed at the end of each item. Use your letter-head—do not use postcards. To facilitate identification, mention the issue and page of RADIO-ELECTRONICS on which the item appears. UNLESS OTHERWISE STATED, ALL ITEMS ARE GRATIS. ALL LITERATURE OFFERS ARE VOID AFTER SIX MONTHS.

SOUND EFFECT CATALOG consolidates two previous editions with new sounds previously unavailable. Offers more than 1,500 effects on more than 250 records. Cross-indexed for easy reference.—MP-TV Services Inc., 7000 Santa Monica Blvd., Hollywood 38, Calif., 25c.

RELAY ADJUSTMENT and maintenance is explored in 8 pages of detailed, illustrated instructions. Full page of terminology in front of book. Also lists tools to speed relay service work.—P. K. Neuses Inc., 511 N. Dwyer St., Arlington Heights, Ill.

RECEIVING TUBES for hi-fi, AM-FM, TV and industry are charted in *Catalog No. L960* according to manufacturer's and EIA type numbers, base, description, heater, limiting values and typical characteristics. Second chart cross-references additional tubes with EIA types. Many drawings.—Mullard, International Electronics Corp., 81 Spring St., New York 12, N. Y.

INDUSTRIAL SOUND SYSTEMS describes and pictures matching components such as loudspeaker columns, amplifiers, preamplifiers, microphones, intercom systems, delayed-sound equipment and inductive paging systems. Accompanying specification sheets.—North American Philips Co., High Fidelity Products Div., Commercial Sound Dept., 230 Duffy Ave., Hicksville, N.Y.

TV TUBE BRIGHTENERS, their specifications and prices are subject of *Guide to Proper Britener Selection*. Proper units for brightening, isolation and tube rejuvenation are matched to picture tubes of various types and heater ratings in booklet's *Quick Selector Chart*.—Perma-Power Company, 3100 N. Elston Ave., Chicago 18, Ill.

HOW TO DECORATE WITH MUSIC uses artist's drawings to illustrate five room arrangements incorporating stereophonic high-fidelity music systems. Floor plans show component placement. Special loudspeaker treatments.—Rek-

FREE

GIANT 1961 204 PAGE CATALOG

BA 1961
ANNUAL CATALOG #11

SINCE 1927

A Complete Buying Guide for Everything in
RADIO TV ELECTRONICS

for DEALERS, SPEECHMANS, SCHOOLS, BROADCASTERS, INDUSTRIALS, THEATRES, MANUFACTURERS, CHURCHES, HOTELS, PUBLIC MUSEUMS, LABORATORIES, ENGINEERS, EXPERIMENTERS, AMATEURS.

INDEX PAGE 201-202 • PHONE BARRINGTON 1-1124

SAVE UP TO 50% ON B-A SELECTED KITS

TOP VALUES IN POWER AND HAND TOOLS

HI-FI AND STEREO SYSTEMS & COMPONENTS

30 PAGES OF BARGAINS NOT IN ANY OTHER CATALOG

100'S OF NEW ITEMS LISTED HERE FOR 1ST TIME

BURSTEIN-APPLEBEE 1019-14 MCGEE ST., KANSAS CITY 6, MO.

BURSTEIN-APPLEBEE CO. Dept. RE
1012-14 McGee St., Kansas City 6, Mo.

Send Free 1961 B-A Catalog No. 611

RUSH COUPON TODAY!

NAME _____

ADDRESS _____

CITY _____ STATE _____

Unbelievable LOW PRICES!

NOT KITS . . . But Factory Wired and Guaranteed

HIGH QUALITY INSTRUMENTS

**New! Model 999
Radio & TV
SIGNAL
GENERATOR**

Provides highly stable signal. Generates R. F. frequencies from 150 Kilocycles to 50 Megacycles. (150 Kc. to 12.5 Mc. on Fundamentals and from 11 Mc. to 50 Mc. on Harmonics). R.F. is obtainable separately or modulated by the Audio Frequency. Measures 7 3/4" x 7 3/4" x 5". Weight 8 Lbs.

Complete—only \$14.95

**New! TC-75 Univ. Combination
TEST SPEAKER &
SIGNAL TRACER**

Plus resistor tester
Plus condenser tester
Plus output indicator
Plus speaker substitution. Plus resistor substitutor
Plus substitute 100 V D.C. power supply
Plus field substitutor. Plus condenser substitutor
Plus voice coil substitutor
Plus signal tracer
Plus universal output transformer
Plus experimental one stage audio amplifier
Measures 7" x 11" x 5". Weight, 8 Lbs.

Complete—only \$19.95

Order directly from **METROPOLITAN ELECTRONICS** • 106 Fifth Ave., New York 11, N.Y.

ALL NEW!



EMC advances in Audio and Test Equipment—by far the Best Values obtainable in Wired or Kit form.

EMC Model 801 RC Bridge and In-Circuit Capacity Checker
A new comprehensive resistance and capacity checker. It measures condensers for actual value, leakage, and power factor. In addition it measures condensers while still connected in their original circuits for opens, shorts or intermittents.
Model 801 Wired\$38.95 — Model 801 Kit\$24.95

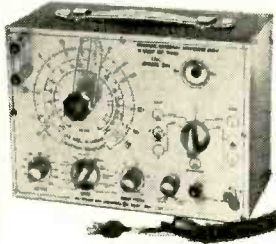

EMC Model 802 Signal Tracer and Generator
Generates its own audio, 1F and RF signal for tracing. Uses both a magic eye tube and a speaker for signal detection. Checks noisy components. Checks and compares magnetic, ceramic and crystal cartridges. Supplied with two shielded audio probes and RF crystal demodulator probe. Model 802 Wired\$38.95
Model 802 Kit\$24.95



EMC Model 107A Peak to Peak Vacuum Tube Volt-Ohm Capacity Meter
6" meter cannot burn out — entirely electronic. Measures peak to peak AC voltages to 2800 volts in 6 ranges. Measures capacity in 6 ranges from 50 mmfd to 5000 mfd. Measures resistance in 6 ranges from .2 ohm to 1000 megohms. Measures DC volts to 1000 volts in 6 ranges. Input resistance 16.5 megohms.
Model 107A Wired\$51.40 — Model 107A Kit\$36.50



EMC Model 214 Stereo Amplifier
A compact, highly attractive dual 14W amplifier with built in preamplifiers having 56 watts peak power output. Has rumble filter and contour control switch. Extremely low distortion and noise level. It can be used as a 28 watts (56 watts peak) monaural amplifier or as a monaural amplifier so arranged that one pre-amplifier is used to drive the internal amplifier while the other preamplifier is used to drive any existing monaural amplifier.
Model 214 Wired\$106.80 — Model 214 Kit\$68.90

Yes, tell me more, send me **FREE** a detailed catalog of the Complete EMC Line. Dept. RE-161
NAME
STREET
CITY STATE.....

EMC Electronic Measurements Corp.
625 B'way, New York 12, N. Y.
Ex. Dept., Pan-Mar Corp., 1270 B'way, New York 1, N. Y.

O-Kut Co. Inc., 38-19 108th St., Corona 68, N. Y.

KIT AND WIRED STEREO and mono high-fidelity, test and ham equipment and radios are featured in manufacturer's 27-page indexed catalog. Detailed descriptions and abundant photos. Prices.—**Electronic Instrument Co. Inc.**, 33-00 Northern Boulevard, Long Island City 1, N. Y.

TUBE CADDY tube stock lists include most tubes used in old and new TV receivers. Suggests stock of tubes technician should carry. *ETR-1477* is for 240-tube case; *ETR-1478* for 160-tube case; *ETR-2071* for 365-tube case.—**General Electric Co.**, Receiving Tube Dept., 316 E. 9th St., Owensboro, Ky.

ELECTRONIC COMPONENTS Catalog 60A gives general and special-purpose use, specifications and prices of microphones and accessories, high-fidelity components, magnetic recording heads and replacement phono cartridges. 28 illustrated pages.—**Shure Brothers Inc.**, 222 Hartrey Ave., Evanston, Ill.

SILICON AND SELENIUM RECTIFIER Catalog 116H presents replacement and cross-reference guide with numbers of rectifiers interchangeable with most popular selenium rectifiers in addition to general information and prices.—**Technical Apparatus Builders**, 6 Church St., New York 6, N. Y.

GUIDE TO HIGH FIDELITY delves into the factors comprising high fidelity, its component parts, what's new in music systems, cutting their costs and closes with a dictionary of the language of audio. Accompanied by many photos and drawings.—**Electronic Instrument Co., Inc.**, 33-00 Northern Boulevard, Long Island City 1, N. Y. 50c

100 JAPANESE TRANSISTORS and their American counterparts are listed in interchangeable chart. Separate price lists.—**Electronic Transistors Corp.**, 9226 Hudson Blvd., North Bergen, N. J.

TAPE CARTRIDGE PLAYERS, 20 monophonic or stereophonic models to handle 1, 2, 3 or 4 tracks on standard 1/4-inch magnetic tape. Play 30-minute to 8-hour continuous tapes for home or industry. Illustrated catalog sheets describe standard units, optional features and accessories; list specifications and prices.—**Magnematic Div., Amplifier Corp. of America**, 398 Broadway, New York 13, N. Y.

ALL-TRANSISTOR TAPE RECORDERS, models TR-1 and AM-1, instruction booklet outlines complete operation in 10 step-by-step figures. Accompanying photos and schematic.—**Rosko-Steele Inc.**, 184 Fifth Ave., New York 10, N. Y.

HIGH-FIDELITY COMPONENTS for stereophonic and monophonic music are featured in *The Critical Ear*. 8-page booklet gives complete performance specifications and prices of manufacturer's line of phono cartridges. Additional details on his tone arm, integrated tone arm and cartridge, stereo-line pre-amplifier and broadcast stereo equalizer.—**Shure Brothers Inc.**, 222 Hartrey Ave., Evanston, Ill. **END**

SCHOOL DIRECTORY

ENGINEERING COURSES



E.E.
Option Electronics or Power Mechanical, Civil & Physics Also in Liberal Arts presented through
HOME STUDY
Resident Classes Also Available if Desired
PACIFIC INTERNATIONAL COLLEGE OF ARTS & SCIENCES
Primarily a correspondence school
5719-M Santa Monica Blvd. Hollywood 38, Calif.

Study in the "Valley of the Sun" ELECTRONIC ENGINEERING TECHNOLOGY

College-level resident schooling Veteran-approved. Catalog on request
Middleton Institute of Electronics
2937 E. McDowell Rd.
PHOENIX ARIZONA

engineering degree in 27 months

You know the advantages college graduates have in industry — more income, rapid advancement. Important firms like Tri-State graduates regularly interview seniors on campus. Become an Electronics Engineer. Qualify faster here.

Bachelor of Science Degree in 27 Months

in Electrical (Electronics or Power major), Mechanical, Chemical, Aeronautical, Civil Engineering. IN 36 MONTHS B.S. in Business Administration (General Business, Accounting, Motor Transport Management majors). For earnest, capable, mature students. Small classes. More professional class hours. Beautiful campus. Well-equipped labs, modernized buildings, new dorms. Year-round operation. Enter Mar., June, Sept., Jan. Founded 1884. Write J. G. McCarthy, Director Admissions, for Catalog and "Your Career in Engineering and Commerce" Book.

TRI-STATE COLLEGE 2411 College Ave. Angola, Indiana

ENGINEERING EDUCATION for the Space Age

NORTHROP INSTITUTE of Technology is a privately endowed, nonprofit college of engineering offering TWO-YEAR accredited technical institute curricula and complete Bachelor of Science degree programs. Students from 40 states, many foreign countries. Outstandingly successful graduates employed in aeronautics, electronics, and space technology. Write today for catalog—no obligation.
NORTHROP INSTITUTE OF TECHNOLOGY
1181 West Arbor Vitae Street, Inglewood 1, California

FREE! ELECTRONICS CAREER KIT

If you're interested in breaking into a good-paying job in Radio-TV-Electronics, I.C.S. will send you absolutely free a famous Career Kit with 3 famous booklets that have helped thousands of others — just like yourself — on the road to real success. Includes:

- 1 "HOW TO SUCCEED" Career Guide — 36-page gold mine of career tips and information.
- 2 "JOB CATALOG" of opportunities in your field of interest.
- 3 "SAMPLE LESSON" (math) to demonstrate the famous I.C.S. method.

Send today for your free I.C.S. Career Kit with these 3 famous booklets. There's no obligation. This may be the big break you've been waiting for. Mark and mail the coupon today.

INTERNATIONAL CORRESPONDENCE SCHOOLS

Dept. 37087M Scranton 15, Penna.
Please send free Career Kit with 3 famous booklets
 General Electronics Radio-TV Serv'g Practical Electrician
 Industrial Electronics Sound Equip. Serv'g Profess'l Eng. (Elec.)
 Radio-TV Eng'g Electrical Eng'g Electrical Drafting
 Electronic Servicing Electrical Tech. Other _____
Name _____ Age _____
Address _____
City _____ State _____

SCHOOL DIRECTORY

SCIENCE ENGINEERING
 BACHELOR'S DEGREE IN 27 OR 36 MONTHS
 Accelerated year-round program: Aero., Chem., Civil, Elec., Mech., Metal., Math., Chem., Physics. Modest rate. Earn board. New classes start Jan., Mar., June, July, Sept. Catalog: 1511 E. Washington Blvd., Fort Wayne 2, Ind.

INDIANA TECHNICAL COLLEGE

GET INTO ELECTRONICS

V.T.I. training leads to success as technicians, field engineers, specialists in communications, guided missiles, computers, radar and automation. Basic and advanced courses in theory and laboratory. Assoc. degree in electronics in 29 mos. B.S. in electronic engineering obtainable. ECPD accredited, G.I. approved. Graduates in all branches of electronics with major companies. Start February, September. Dorms, campus. High School graduate or equivalent. Catalog.

VALPARAISO TECHNICAL INSTITUTE
 Dept. C Valparaiso, Indiana



Learn Transistor Electronics At Home!

■ Prepare now for a profitable career in this growing field. Learn theory, construction and applications of all types of transistors with this proven home-study course from the Philco Technological Center.

FOR FREE INFORMATION PLEASE WRITE TO:

PHILCO® TECHNOLOGICAL CENTER
 "C" and Ontario Sts., Philadelphia 34, Pa.

AT LAST! A home study course covering all phases of electric and electronic organ servicing.

A NEW COURSE An extensive course covering every make of organ—repair, regulating, and troubleshooting.

Electronic
ORGAN SERVICING

Your Opportunity To Get Into A New, Rapidly Expanding Field At The Start. Don't Miss It!!

WRITE NOW FOR FREE BOOKLET

NILES BRYANT SCHOOL
 Dept. E., 3731 Stockton Blvd. Sacramento 20, California

NHSC Approved * The Pioneer School
 Established 1898

LEARN

LEARN RADAR MICROWAVES COMPUTERS—TRANSMITTERS CODE • TV • RADIO

Phila. Wireless Technical Inst. 1533 Pine St., Philadelphia 2, Pa.
 A Non-Profit Corp. Founded in 1908
 Write for free Catalog to Dept. RE-1
 Classes now forming

ELECTRONICS

PREPARE FOR A GOOD JOB!
 BROADCAST ENGINEER
 RADIO SERVICING AUTOMATION

TELEVISION SERVICING
 BLACK & WHITE—COLOR

APPROVED FOR VETERANS AND SURVIVORS OF VETERANS
 BUILDING AIR CONDITIONED
 SEND FOR FREE LITERATURE

BALTIMORE TECHNICAL INSTITUTE
 1425 EUTAW PLACE, BALTIMORE 17, MD.

ENGINEERING HOME STUDY COURSES

Courses written by world authorities in all branches of engineering and science and proved successful by thousands of our graduates. One hour each day in your spare time will start you off to higher pay, security and prestige. Personalized instruction methods ensure rapid progress. Fill in the coupon and indicate the course of interest. We will send you a complete outline of the course and a booklet describing the Institute and our advanced teaching methods.

RADIO ELECTRONICS
 TELEVISION
 CIRCUIT
 MATHEMATICS
 ELECTRICAL ENG.
 TELEPHONY
 CIVIL ENG.
 SURVEYING
 ARCHITECTURE
 FORESTRY
 MINING
 STRUCTURAL
 MECHANICAL ENG.
 INDUSTRIAL ENG. & MANAGEMENT
 REFRIGERATION
 DRAFTING
 PLASTICS
 AERONAUTICAL ENG.
 HIGH SCHOOL
 CHEMICAL
 MATHEMATICS
 JOURNALISM
 ACCOUNTING

MAIL THIS COUPON TODAY

CANADIAN INSTITUTE OF SCIENCE & TECHNOLOGY LIMITED
 761 Century Bldg., 412, 5th St. N.W., Wash., D.C.

NAME.....
 ADDRESS.....
 CITY.....STATE.....

COURSE OF INTEREST.....
 Canadians: Send to C.I.S.T., 761 Garden Bldg., 263 Adelaide St. West, Toronto, Ontario.

C. I. S. T.

FREE CAREER BOOKLET

YOUR CAREER

M.S.O.E.

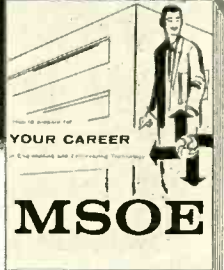

to guide you to a successful future in

ELECTRONICS RADIO-TV COMPUTERS ELECTRICAL ENGINEERING

This interesting pictorial booklet tells you how you can prepare for a dynamic career as an Electrical Engineer or Engineering Technician in many exciting, growing fields:

MISSILES • RADAR • RESEARCH ELECTRICAL POWER • ROCKETRY AUTOMATION • AVIONICS SALES • DEVELOPMENT

Get all the facts about job opportunities, length of study, courses offered, degrees you can earn, scholarships, part-time work — as well as pictures of the Milwaukee School of Engineering's educational and recreational facilities. No obligation — it's yours free.

MILWAUKEE SCHOOL OF ENGINEERING

MAIL COUPON TODAY!

MILWAUKEE SCHOOL OF ENGINEERING
 Dept. RE-161, 1025 N. Milwaukee St. Milwaukee, Wisconsin MS-113

Please send FREE "Your Career" booklet
 I'm interested in Electronics Radio-TV
 Computers Electrical Engineering
 Mechanical Engineering
 (PLEASE PRINT)

Name.....Age.....
 Address.....
 City.....Zone.....State.....
 I'm eligible for veterans education benefits.
 Discharge date.....

Professional Technicians Use CASTLE'S Complete

TV TUNER OVERHAUL

ALL MAKES
ONE PRICE
\$9⁹⁵

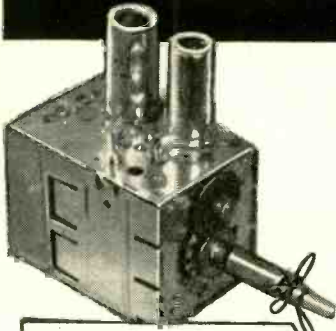

SAME DAY SERVICE!
on Popular Types
48 Hours most Others.

VHF TUNERS • UHF TUNERS • UV Combinations*

Castle overhaul charge includes all labor and minor parts and written 90 day warranty. Tubes and major parts are extra at net prices. Tuner to be overhauled should be shipped complete; include tubes, shield cover and any damaged parts. Write down model number and state complaint. Pack well and insure.

Castle pioneered TV Tuner Service almost a decade ago. Overhauling TV Tuners is our only business and all specifications are met exactly

*UV combination tuner must be of one piece construction. Separate UHF and VHF tuners with cord or gear drives must be dismantled and the defective unit only sent in.

Castle TV TUNER SERVICE, INC.

5710 North Western Avenue • Chicago 45, Illinois
In Canada: 136 Main Street • Toronto 13, Ontario



Model 500
COMPONENT SUBSTITUTOR

✓ One compact instrument substitutes for resistors, condensers, electrolytics, rectifiers, diodes, power resistors and bias voltage.

✓ SAVE MONEY! No need to buy several different component substitutors ... The Model 500 does the whole job!

PROVIDES A COMPLETE RANGE OF COMPONENTS AT YOUR FINGERTIPS FOR FAST SUBSTITUTION

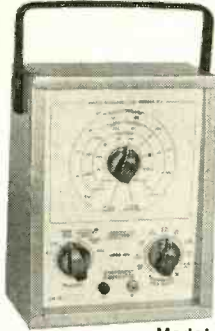

Model 500

SPECIFICATIONS

- Substitutes for 20 values of resistors from 33 ohms to 10 megohms
- Substitutes for 10 values of condensers from .0001 mfd. to .5 mfd.
- Substitutes for 10 values of electrolytics from 4 mfd. to 330 mfd.
- Substitutes for all power rectifiers up to 500 ma.
- Substitutes for all diodes
- Substitutes for power resistors ... continuously variable up to 5000 ohms
- Substitutes for bias voltages ... continuously variable up to 15 volts either polarity

\$29⁹⁵
Net

See your electronics parts distributor!

MERCURY ELECTRONICS CORP. 77 SEARING AVENUE, MINEOLA, NEW YORK

TV PICTURE TUBES AT LOWEST PRICES

ALL ALUMINIZED GLASS TYPES

Type	Price With Old Tube	Type	Price With Old Tube	Type	Price With Old Tube
10BP4	7.95	17B/P4	11.50	21CEP4	21.00
12LP4	8.95	17CP4	11.50	21CX4	15.75
14AJP4	14.00	17CK/CA/BZ/		21DEP4	21.00
14ATP4	14.00	BRP4	17.00	21DFP4	21.00
14B/E/CP4		17DP4	17.00	21DL4	21.00
	10.00	17H/RP4	12.50	21DSP4	21.00
14HP4	11.00	17L/VP4	12.50	21EP4	14.25
14QP4	11.00	17QP4	11.50	21FP4	14.50
14RP4	11.00	20C/DP4	13.50	21WP4	16.00
14W/ZP4	11.00	20M/MP4	14.50	21XP4	16.50
14XP4	11.60	21AC/DS/		21YP4	16.00
16DP4	12.00	AWP4	15.75	21ZP4	15.50
16K/RP4	9.95	21AL/ATP4		24C/VP4	23.50
16LP4	12.50	21AU/AVP4	16.75	24EP4	24.50
16TP4	9.95			24HP4	26.50
16WP4	12.00		15.75	24DP4	24.50
17AT/AVP4		21AWP4	15.75	27EP4	39.95
	12.50	21BTP4	16.75	27FP4	39.95
17BP4	9.95	21CBP4	16.75	27SP4	40.95

METAL TYPES

12UP4	12.00	16GP4	14.50	19AP4	16.00
16AP4	13.50	17CP4	17.00	19FP4	19.75
16EP4	14.00	17GP4	17.00	21MP4	20.75
		17TP4	17.60		

TEST TUBES

8XP4	16.07	8YP4	16.07
------	-------	------	-------

1 year warranty

Prices include the return of an acceptable similar tube under vacuum. These tubes are manufactured from reprocessed used glass bulbs. All parts and materials including the electron gun are brand new.
ALL PRICES FOR CHICAGO, ILLINOIS. Deposit required, when old tube is not returned, refundable at time of return. 25% deposit required on COD shipments. Old tubes must be returned prepaid. Tubes shipped Rail Express. Shipped only to Continental U.S. and Canada.

WRITE FOR COMPLETE LIST

—PICTURE TUBE OUTLET—
2922 MILWAUKEE AVE., CHICAGO 18, ILLINOIS
Dickens 2-2048

HI-FI & STEREO COMPONENTS

Send us your list for a SPECIAL PACKAGE DEAL QUOTE

No sale too small. Tradesins accepted. BONAFIDE offers biggest discounts on all standard brands. Expert advice and full guarantee are assured at

BONAFIDE ELECTRONICS
Dept. RE-1, 89½ Cortland St., N.Y. 7, N.Y.
WE WILL NOT BE UNDERSOLD

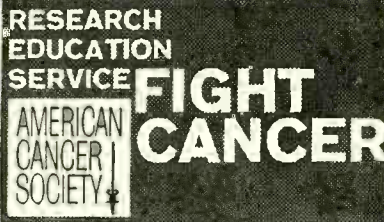

TAPE RECORDERS

HI-FI COMPONENTS SLEEP LEARN KITS
MERITAPE UNUSUAL VALUES
Low cost, high quality recording FREE
tape in boxes or cans. 1961 CATALOG
DRESSNER, 69-02RE 174 St., Flushing 65, N.Y.



101 WAYS TO USE YOUR VOM AND VTVM, by Robert G. Middleton. Howard W. Sams & Co. Inc., 1720 E. 38 St., Indianapolis 6, Ind. 5½ x 8½ in. 116 pp. \$2.

Another in the 101 series by this well known author, the text covers two of the most used test instruments. It shows how to use them to make equipment checks, dc voltage tests; ohmmeter, signal-tracing, ac voltage, and dc current tests. Radio and TV alignment applications are also covered.—LS

INTRODUCTORY ELECTRIC CIRCUITS, by John B. Walsh and Kenneth S. Miller. McGraw-Hill Book Co., 330 W. 42 St., New York 36, N. Y. 6 x 9 in., 353 pp. \$8.50.

An excellent book on basic dc and ac circuits, it analyzes two- and four-terminal networks, filters and transformers. Polyphase circuits are also treated. Toward the end, several chapters are devoted to mathematical subjects: Fourier series, Laplace transforms, matrix algebra, etc. The reader should know differential and integral calculus and basic physics. Many problems and numerical examples are included.

ALTERNATING-CURRENT CIRCUITS, Fourth Edition, by Russell M. Kerchner and George F. Corcoran. John Wiley & Sons, Inc., 440 Park Ave., New York 16, N. Y. 6 x 9 in., 602 pp. \$8.75.

This is a detailed text limited to ac only. The level is that of the junior year, and math preparation to calculus is sufficient. Basic networks, phasor algebra, sinusoidal and nonsinusoidal waves are among the topics, with many problems and numerical examples worked out in the text. The authors go deeply into power generation and distribution with chapters on transmission lines, polyphase circuits and filters.

PRACTICAL RADIO AND ELECTRONICS COURSE FOR HOME STUDY (Revised 1960 Edition). 216 pp. \$3.95. TELEVISION SERVICING COURSE. 192 pp. \$3.

Both books prepared under direction of M. N. Beitman. Supreme Publications, 1760 Balsam Road, Highland Park, Ill. 8½ x 10½ inches.

Earlier editions of these two books are known to many readers and are popular with experimenters and others interested in learning the fundamentals of radio, TV and electronics. The 35-lesson radio-electronics course begins with the basic radio receiver, its components and diagrammatic symbols and progresses through af and rf amplifiers, power supplies and test instruments to such subjects as strain gauges, high-frequency heating, transistors and servicing printed circuits. Excellent supplementary reading for students who may be having trouble with more

(Continued on page 128)

FREE!

LAFAYETTE'S 1961 CATALOG

324 GIANT SIZED PAGES

The Complete Catalog Featuring
"The Best Buys In The Business"

- Stereophonic Hi-Fi Equipment
- Public Address Systems
- Tape Recorders
- Radio and TV Tubes and Parts
- Citizen Band Equipment
- Amateur Equipment
- Industrial Supplies

Send for Lafayette's FREE Catalog—the most complete, up-to-the-minute electronic supply catalog crammed full of everything in electronics at our customary down-to-earth money-saving prices.

CONTAINS HUNDREDS OF EXCLUSIVE LAFAYETTE ITEMS NOT AVAILABLE IN ANY OTHER CATALOG OR FROM ANY OTHER SOURCE—SEND FOR YOUR COPY NOW!

A "must" for the economy-minded hi-fi enthusiast, experimenter, hobbyist, engineer, technician, student, serviceman and dealer



Our 40th Year

EASY PAY PLAN—the simplest, and quickest way to get what you want when you want it. As little as \$2 down . . . up to 24 months to pay.



Communications Receiver
KT-200, Kit HE-1C, Wired
64.50 79.95



RK-400 2-Speed
Portable Tape Recorder
49.50

TE-15 Tube Checker
19.95



TM-14
Radio Field Indicator
6.95



RW-60 20,000 Ohms Per
Volt Multimeter
13.50

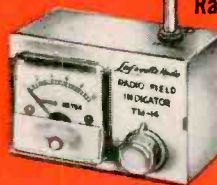

HE-800WX
Citizen Band Mobile Antenna
6.95

LAFAYETTE RADIO

Mail the coupon today for your
FREE copy of Lafayette Radio's
1961 catalog.



Lafayette Radio Electronics Corp.
Dept. JA-1 P.O. Box 190
Jamaica 31, N. Y.

Send me the FREE Lafayette 324 page
1961 catalog 610

Name _____

Address _____

City _____ Zone _____ State _____

FROM LAFAYETTE

America's Citizens Band Headquarters



Trucking



On the Farm



Boating

3 GREAT NEW CITIZENS BAND TRANSCEIVERS

CITIZENS BAND — The New Two-Way Personal Communications Method For Everyone. Fill out the FCC form enclosed with each Lafayette Transceiver. No examination or technical knowledge required—Any citizen 18 years or older is eligible for a license.

IDEAL FOR BUSINESS, CAR, BOAT, FARM, INDUSTRY, PERSONAL & SPORTS USE

LAFAYETTE 9 TRANSISTOR PORTABLE CITIZENS BAND "WALKIE-TALKIE"



HE-29

Complete Portable Two-Way Communication — with No License Required!

49⁵⁰

2.00 Down

Two for 96.50

- Pocket Size — 6³/₈" x 3¹/₄" x 1⁵/₈"
- Fully Transistorized—9 Transistors plus 1 Diode
- Transmits & Receives Up To 10 Miles (Under Favorable Conditions)
- Uses Inexpensive Penlight Batteries
- Telescoping Antenna — 3 ft. 9 in.
- Complete With Earphone For Private Listening
- Supplied With Attractive Leather Carrying Case & Crystals For Channel 10

Constructed with the care and precision of a fine watch. This new transceiver combines a portable transmitter and superheterodyne receiver designed for short range communication in the 27 mc Citizens Band. Advanced circuitry and design utilizes 9 transistors plus 1 diode to achieve a range of from 1.5 miles to 10 miles depending upon conditions. Low input power of 100 MW permits operation without FCC license or permit. Easy-to-use speaker serves as microphone, controls include push-to-talk switch and on-off volume control. Housed in sturdy aluminum case. Supplied with 8 miniature penlight batteries, earphone and attractive leather case with shoulder strap.

LAFAYETTE HE-20 DELUXE CITIZENS BAND TRANSCEIVER

MADE IN U.S.A.



HE-20

- Foolproof Dependable Relay Switching
- 14 Tube Performance, plus 3 Diodes
- 4 Crystal-Controlled Transmit Positions

- 4 Crystal-Controlled Receive Positions Plus Tuneable Receiver over all 23 channels
- "S" Meter with Switch To Measure Signal Strength and To Check on Wattage Input to Final
- Dependable Push-To-Talk Ceramic Microphone & Relay
- Adjustable Squelch Control
- Highly Effective Automatic Series Gate Noise Limiter
- Illuminated Dial
- Built-In 12 Volt Power Supply For Mobile Use
- Comes Complete with Matched Crystals for Channel 9

COMPLETELY

WIRED!

NOT A KIT!

99⁵⁰

5.00 Down

The sensitivity and selectivity of this new transceiver equals that of the finest units available. Two or more of these transceivers will serve as an effective communications system over a distance of up to 20 miles, depending upon terrain and antenna height. Tunable Superheterodyne receiver section covers all 23 assigned channels with a sensitivity of 1 microvolt and provides for 4 crystal controlled receiving channels. 5-watt crystal-controlled transmitter operates on any 4 of 23 channels. Complete with rugged push-to-talk ceramic mike. Special bracket-handle allows installation in any location and any position. Size 12x5x8¹/₂" D with 115V AC/12V DC Power Supply.

LAFAYETTE HE-15A CITIZENS BAND TRANSCEIVER

Not Superregenerative but SUPERHET!
THE GREATEST VALUE in The CITIZENS BAND FIELD



HE-15A

Completely
Wired

57⁵⁰

Made in U.S.A.

5.00 Down

- HE-15A Wired & Tested (less antenna)..... Net 57.50
- HE-19 Whip Antenna..... Net 3.95
- HE-16 Power Supply for 12 Volts..... Net 10.95
- HE-18 Power Supply for 6 Volts..... Net 10.95

- 5 Crystal-Controlled Transmitting Positions
- Superheterodyne Tuneable Receiver Over Full 23 Channels
- 4 Dual Function Tubes, 2 Single Function Tubes plus 2 Rectifiers for 12 Tube Performance
- Planetary Vernier Tuning
- Effective Full-Wave Variable Noise Limiter
- RF Jack on Front Panel
- High Output Crystal Microphone
- 5-Prong Microphone Jack for Easy Relay Addition
- Complete with Transmitting Crystal for Channel 9



LAFAYETTE
RADIO

PLEASE INCLUDE SHIPPING CHARGES WITH ORDER

165-08 LIBERTY AVENUE, JAMAICA 33, N. Y. • OTHER LOCATIONS

NEW YORK, N. Y.
100 6th Avenue

NEWARK, N. J.
24 Central Avenue

BRONX, N. Y.
542 E. Fordham Rd.

PARAMUS, N. J.
182 Route 17

BOSTON, MASS.
110 Federal Street

PLAINFIELD, N. J.
139 W. 2nd Street

LAFAYETTE
HI-FI KITS

Build A Path to A New World of Entertainment

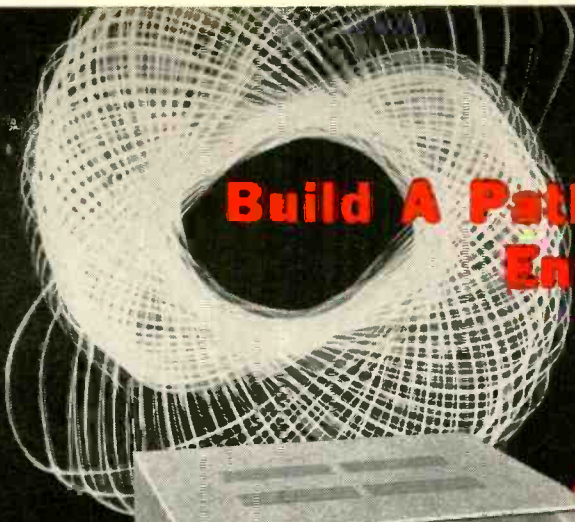

KT-250A
50-WATT STEREO AMPLIFIER . . . 74.50



KT-500A
FM-AM STEREO TUNER . . . 74.50



KT-600A STEREO
PREAMPLIFIER . . . 79.50

ENGINEERING:

Created with the non-technical builder in mind. There's much more fun in assembling your own kit . . . and it's so easy.

DESIGN:

Each kit has the fine professional - looking touch. Styled to blend with every decor.

VALUE:

You can't get better units at these money - saving prices.

QUALITY:

Top performance due to high quality parts and engineering.



KT-650
FM TUNER . . . 54.50



KT-236A 36-WATT
STEREO AMPLIFIER . . . 59.50

MONEY-BACK GUARANTEE
Lafayette Kits are exclusive products of Lafayette Electronics. Each Lafayette Kit must meet or exceed its published specifications, or your money is refunded in full.

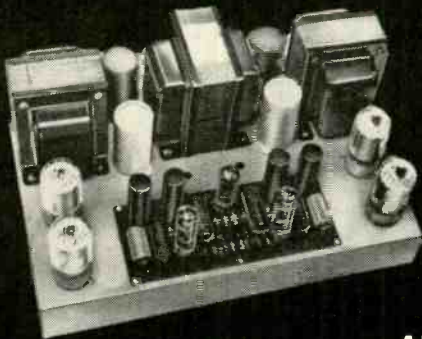

KT-270 70-WATT
BASIC STEREO AMPLIFIER . . . 89.50



KT-550 100-WATT
BASIC STEREO AMPLIFIER . . . 134.50

All Lafayette Kits Made in U.S.A.
All Lafayette Kits are Available on the Easy Pay Plan.

"TAB" Tubes Tested, Inspected, Boxed
Six Months Guarantee! No Rejects!
NEW & Used Gov't & Mfrs. Surplus!

Orders \$10 or more. Receiving tubes only pvd. 48 states

0A2	.80	6B8J6	.60	12AT6	.50	18X1	1.00
0B2	.80	6BK7	.60	12BH7	.50	11Z6	1.10
0C3	.60	6BL7	1.25	12AU6	.60	4-65A	16.00
0D3	.35	6BN6	.98	12AU7	.60	2D21	2.81
0X4	.50	6CQ6	.60	12BD6	.75	4-250	35.00
1A7	.50	6BZ7	1.25	12BA6	.65	717A	5.81
1B3	.78	6C4	.43	12BA7	.90	4-125	20.00
1R5	.78	6C5	.43	12BD6	.60	4-250	35.00
1S4	.78	6C8B	.80	12BE6	.50	4E27	7.00
1T4	.78	6CDB	1.40	12BF6	.50	4PR60	29.50

Send 25c for Catalog

1U4	3/51	6H6	.99	4X150G	\$15
1U5	.73	6J5	.52	4X250	35.00
6E1	.68	6K4	.48	4X500	38.00
3Q4	.80	6K5	.59	12CU6	1.55
3Q5	.86	6K6	1.05	12SA7	.64
354	.68	6L6	1.19	12SC7	.89
3V4	.83	6S4	.59	12SH7	.89
5R4	.98	6S8	.99	12SJ7	73
5U4	.75	6SA7	.60	12SK7	.94
5V4	.80	6SB7	1.10	12SQ7	.84

Wanted Surplus Electronic Schools, E. E.

5Y3	.50	6S7	.80	198G6	2.15	450T	42.00
6B4	.50	6S7	.79	19T8	1.16	807	1.00
6AC7	.71	6S8	.59	12CU6	1.39	929	3.00
6AC7	.89	6S7	.60	25L6	.69	811	4.40
6AH6	.90	6SK7	.72	25W4	.77	812	3.00
6AK5	.60	6SL7	.80	25Z5	.63	813	9.00
6AL5	2/3	6S7	2/3	25Z5	.63	813	9.00
6AG5	.63	6SQ7	.74	EL34	3.49	815	2.75
6AS7	3.00	6SR7	.79	EL37	2.49	826	1.00
6AT6	.40	6TB	.60	829B	8.00		

Wanted 30A TL tubes! Top \$ & P

6AU4	1.10	6UB	.98	35W4	.49	822A	7.00
6AU5	1.15	6V6GT	.70	35Y4	.69	872A	3.50
6AU6	.69	6W4	.79	6A5	.25	872B	1.95
6AX4	.70	6W6	.80	50A5	.69	6146	4.00
6BA6	.50	6X4	2/31	50B5	.69	5879	.98
6BA7	1.00	6X5	.49	6A5	.69	5881	2.70
6BD6	.60	6Y6	.97	50L6	.69	6550	3.00
6BE6	.50	7N7	.89	KT66	3.29	5654	1.00
6BG6	1.50	12AL5	.59	72C7	1.25	5024	12.00
6BH6	.72	12A5E5	.75	60	.59	7193	10/\$1

TUBES WANTED! WE BUY! SELL & TRADE!

NEW POWER CONVERTER KIT & BUILT

12VDC to 500VDC up to 200Ma 100 Watts: Tap at 250VDC Type C1250B \$35. C1250K in KIT Form \$32. Hi efficiency, low ripple, low idle current—Silicon rectifiers, toroidal filter, Mag-metal tape wound transformer, fused & short circuit proof, small in size! Quiet! Light weight! C1250B \$43.50 built, ready to go. Conservatively Rated. Delco Transistors Heavy Copper-Heatsink. 12VDC to 500VDC up to 100Ma Type C1225B \$30. C1225K \$28. Kits are preassembled.



TRANSISTORS & ACCESSORIES

2N411	\$3.	2N442	\$4.50	2N277	\$4.	2N278	\$5.
2N155	\$1.25	2N157	\$1.60	2N177	\$1.75	2N178	\$1.75
1.75	2N247	\$1.50	2N255	\$1.20	2N270	\$1.25	
2N271	\$1.25	2N408	\$3.80	2N514	\$1.20	2N378	\$1.80
2N570	\$2.20	2N581	\$1.25	2N582	\$2.10		
2N174	\$8.50	2N175	\$6.50				

DIAMOND BASE MICA MOUNTING KIT \$.30
DELCO ROUND BASE MICA MOUNTING KIT \$.30
DELCO POWER HEAT SINK WITH FINS \$.75

"VACDAC" SILICON TUBE RECTIFIER

WITH BUILT IN RF SURGE & SERIES BALANCING PROTECTION

TYPE	VRMS/PIV	AMPS	PRICE
ST866	5000/10400	0.3	\$20.00
ST816	5000/1000	0.3	\$16.00
ST814	1900/2800	0.5	\$15.00
ST74	1120/1600	0.6	\$8.00



★ NEW "TEKSEL" SELENIUM RECTIFIERS

FULL WAVE BRIDGE RECTIFIERS. ONE YEAR GTDI

AMP.	18VAC	36VAC	72VAC	144VAC
CONT.	14VDC	28VDC	56VDC	112VDC
1AMP	\$ 1.30	\$ 2.00	\$ 4.90	\$ 9.45
2AMP	2.90	4.00	8.25	16.20
3AMP	2.90	4.00	8.60	16.75
6AMP	4.15	8.00	18.75	36.15
10AMP	6.10	11.15	28.30	48.90

Write for Complete Rectifier Catalog



NEW BATTERY CHARGER BC6-12V

For 6 or 12 Volt Batteries, Trickle & Full Charge up to 4 amp

Charges 6 & 12 volt batteries. Built BC6-12V.....\$10.00



"TAB" KITS! "TAB" THE BEST KITS! "TAB"

All Kits Contain Most Popular Valve Sizes

Kit 2 Eng. Parallel Rules	Kit 5 Sub-Min Tubes
Kit 35 Precision Resistors	Kit 40 Standoff Insulators
Kit 10 Switches	Kit 35 Power Resistors
Kit 75 Resistors 1/2 1/2W	Kit 75 Mica Condensers
Kit 150 Carbon Resistors	Kit 5 Crystal Diodes
Kit 25 Panel Lamps	Kit 100 Fuses, Assorted
Kit 12 Electrolytic Cond's	Kit 10 Ceramic Cond's
Kit 56 Tube Sockets	Kit 10 Germanium Diodes
Kit 65 Tubular Cond'sers	Kit 5 FT243 Xtal Holders
Kit 500 Lugs & Eyelets	Kit 8 Silicon Diodes
Kit 10 Bathing Oil Cond's	Kit 5 Microswitches
Kit 5 lbs. Surprise Pckg.	Kit 4 Asst Rectifiers
Kit 10 Xmitter Mica Cond's.	Kit 2 PNP Transistors
Kit 3 Phone/Patch Xfms	Kit 4X50 Ft Hookup Wire
Kit 3 Searchlights	Kit 2 Veeder Counters
Kit Circular Slide Rule	Kit 2-Computer Toroids
Kit 12 Algr. Clip Ass't'd.	Kit High Gain XTAL Mike

BUY 10 KITS—GET ONE FREE! EACH KIT 99¢

NEW SILICON 750MA* DIODES TOP HATS

GENERAL PURPOSE	400 PIV at 300 MA
SPECIAL 2 FOR \$1	25 FOR \$10
rms/piv 35/50	rms/piv 140/200
rms/piv 280/400	rms/piv 490/700
55¢	\$1.25
rms/piv 630/900	rms/piv 770/1100
\$1.50	\$2.50

* CAPACITOR INPUT DERATE 20%: (\$5 or more this item we pay P.P./U.S.)

"TAB" TERMS: Money Back Guarantee Our 15th year. \$2 min. order F.O.B. N.Y.C. Add shpg charges or for C.O.D. 25% Dep. Prices shown subject to change.

111-GA LIBERTY ST., N. Y. 6, N. Y.
Send 25c for Catalog
PHONE: RECTOR 2-6245

(Continued from page 124)
advanced texts. A logical prerequisite to the TV course.

The TV servicing course (14 lessons) is more detailed and presupposes a knowledge of basic radio and electronic circuitry. Much of the material is taken from manufacturers' service data and is well illustrated and concise.

MODERN NETWORK SYNTHESIS, by M. E. Van Valkenburg. John Wiley & Sons Inc., 440 Park Ave. So., New York, N. Y. 6 x 9 in., 498 pp. \$11.75.

This book is written for students at graduate level. It begins with a review of circuit analysis and mathematical methods. Approximations are treated in two chapters. One- and two-terminal-pair networks are discussed. Each chapter contains many problems and numerical examples.—FS

SERVICING TV VIDEO SYSTEMS, by Jesse E. Dines. Howard W. Sams & Co. Inc., 1720 E. 38 St., Indianapolis 6, Ind. 5 1/2 x 8 1/2 in. 222 pp. \$3.95.

Written for the service technician, this book covers the video chain in the TV receiver—video if amplifiers, video detector, video amplifier and picture tube. It starts by reviewing the fundamentals of video systems and follows up with chapters on characteristics, circuits, alignment and circuit variations. Then the author goes into construction, replacement, repair, troubleshooting and service hints.—LS

THE ARITHMETIC OF COMPUTERS, by Norman A. Crowder. Doubleday & Company Inc., Garden City, New York. 5 1/2 x 8 1/2 in. 472 pages. \$3.95.

An excellent text with a built-in teacher. Only a minimum of basic mathematics is required—addition, subtraction, division, multiplication—everything else necessary is detailed in the text. The unique approach used in this text comes close to packaging a live instructor with each book. First you study a small section of new material, then you are questioned about what you have just read and, if you make a mistake, the text explains your error in detail. Then, you are told to go on and try to answer the question again.

A student cannot get to the end of the book without understanding it, as there is no way to skim through without knowing the correct answers, which in turn require a knowledge of the subject material.—LS

TECHNICIAN'S HANDBOOK (1960 revision, 3rd edition). CBS Electronics, Danvers, Mass. 4 1/4 x 8 3/4 in.

Electronic technicians depend greatly on their tube-transistor manual. This handbook presents full data on all common types, with clear basing diagrams on the same page as the data. The information given has been selected for maximum usefulness.

Seldom-used types are described in shorter form. Separate tables list diodes, converters and tuning eyes. Other tables include pix tubes, foreign types and special-purpose tubes. An appendix contains further useful information: rectifier charts, tube testing, pix-tube installation, and color codes.—IQ

JUNCTION TRANSISTORS IN PULSE CIRCUITS, by P. A. Neefeson. Macmillan Co., 60 Fifth Ave., New York 11, N.Y. 6 x 9 in. 139 pp. \$5.50.

This is a specialized text for engineers and designers who are concerned with computers, switch circuits, frequency dividers and logic circuits. It develops the mathematical analysis, and follows with an experimental circuit to prove the theory. Pulse shaping, feedback, transients, multivibrators are discussed in detail.—IQ

CORRECTION

The base diagram of the 2N256 power transistor was drawn incorrectly in Fig. 3 of the article on the Rally-Pal Computer and in Fig. 1 of the article on the automobile FM tuner on pages 48 and 57, respectively, of the November, 1960 issue. In both cases, the base and emitter terminals were transposed. Looking at the bottom of the transistor with the pins in a vertical row to the left of center, the emitter is at the top and the base at the bottom.

Our thanks to Mr. Wm. F. Alexander, W3GFZ, of Newtown, Pa., for spotting and reporting these errors.

PACKAGE HI FI or SINGLE COMPONENTS
You'll find our prices low and service fast.
Write for our quotation
CENTER INDUSTRIAL ELECTRONICS, Inc.
74-R Cortlandt Street, New York 7, N.Y.

A NOTE TO THE HI-FI BUYER
AIR MAIL us your requirements for an IMMEDIATE LOWEST PRICE QUOTATION Components, Tapes and Recorders SHIPPED PROMPTLY AT LOWEST PRICES
WRITE TODAY FOR FREE CATALOG
AUDIO UNLIMITED 190-R Lexington Ave. New York 16, N. Y.

HI-FI RECORDING TAPE
Splice Free (except 2400")
15 day money-back guarantee

1200' 7" acetate	\$1.29	3-	12+	24+
1800' 7" acetate	1.79	1.59	1.99	1.45
1800' 7" mylar	2.09	1.99	1.99	1.85
2400' 7" mylar	3.29	2.99	2.99	2.75
2400' 7" tensitized mylar	4.25	3.95	3.95	3.75

Can Be Assorted. Add 15c Postage Per Reel. 10c For 24+ Lot Orders.

HI-FI COMPONENTS TAPE RECORDERS available from wide variety of stock and shipped within 24 hours. Write for free wholesale catalogue. "WE WILL NOT BE UNDERSOLD." Write us and see why.

CARSTON 125-RD East 88 St. New York, 28, N. Y.

Learn to Service ELECTRIC APPLIANCES

Tremendous jump in electrical appliances and devices has increased need for servicemen. Good money-making opportunities for young and older men. Benefit soon these free ways: (1) fix appliances after hours, weekends; (2) have full time service shop; (3) fill job openings being advertised; (4) go into sales and service business; (5) save, fix own appliances. Beginners learn at home. Professional Tester Kit furnished. Low cost, monthly terms. Information free. Mail coupon.

NATIONAL RADIO INSTITUTE
WASHINGTON 16, D.C.

Name.....
Address.....
City.....Zone.....State.....

ADVERTISING INDEX

Radio-Electronics does not assume responsibility for any errors appearing in the index below.

Aerovox Corp.	16	North American Philips Co., Inc. (Norelco) ..108	
Airex Radio Corp.	108	Ohmatsu Electric Co. Ltd.	129
Allied Radio Corp.	9, 18, 19	Olson Radio Corp.	82
Audio Unlimited Inc.	128	Paco Electronics Co., Inc.	83
Audion	117	Picture Tube Outlet	124
B. & K. Mfg., Co.	99	Progressive "Edu-Kits" Inc.	107
Barry Electronics Corp.	109	Quam-Nichols Company	26
Bonafide Radio	124	Quietrole Co., Inc.	112
Brooks Radio & TV Corp.	111	RCA Electron Tube Div.	Back Cover
Burstein-Applebee Co.	121	RCA Institutes	76-79
Capitol Radio Engineering Institute	90-93	Rad-Tel Tube Co.	130
Carston Studios	128	Radio-Electronics Master	104
Castle TV Tuner Service Inc.	124	Radio Shack Corp.	117
Center Industrial Electronics Inc.	128	Radio TV Training School	21
Centralab Div. of Globe Union Inc.	10	Rinehart & Co.	24
Claroostat Mfg., Co., Inc.	13	Rider Inc. (John F.)	116
CLASSIFIED ADS P. 119		Sams & Co., Inc. (Howard W.)	102, 103
Cleveland Institute of Electronics	11	Schober Organ Co.	84
Columbia Record Club	7	Selectronics	110
Coyne Electrical School	15, 109, 118	Service Instruments Corp. (Sencore)	89
Delco Radio Div. of General Motors Corp.	14	Simpson Electric Co.	8
DeVry Technical Institute	105-106	Sound Publishing Co., Inc.	110
Dressner	124	Sprague Products Co.	25
Editors & Engineers	112	Superscope, Inc. (Sony)	110
Electro-Voice, Inc.	23	Supreme Publications	115
Electronic Chemical Corp.	108	Sylvania Electric Products Inc.	2nd Cover
Electronic Instrument Co. (EICO)	29, 30	T A B	128
Electronic Measurement Corp.	122	Tarzian, Sarkes	114
Electronic Publishing Co., Inc.	111	Triad Transformer Corp.	94
Fair Radio Sales	114	Tung-Sol Electric Co.	20
Electronics Illustrated	113	United Catalog Publications	104
Fisher Radio Corp.	12	D. Van Nostrand Co., Inc.	129
Gernsback Library, Inc.	120	Vidaire Electronics Mfg., Corp.	117
Gratham School of Electronics	17	Warren Dist. Co.	117
Harman-Kardon	3rd Cover	Weller Electric Corp.	22
Heald Engineering College	117	Xcelite, Inc.	95
Heath Company	68-71		
Holt, Rinehart & Winston Inc.	24		
Indiana Technical College	110		
Institute of Radio Engineers	118		
Key Electronics	109		
Lafayette Radio Electronics Corp.	125-127		
Lektron Inc.	112		
Mercury Electronics	110, 112, 114, 116, 119, 124		
Metropolitan Electronics	121		
R. A. Moor Co.	115		
Moss Electronics Inc.	86, 87		
National Radio Institute	3, 27, 28, 128		
National Technical Schools	5		

Printed in USA

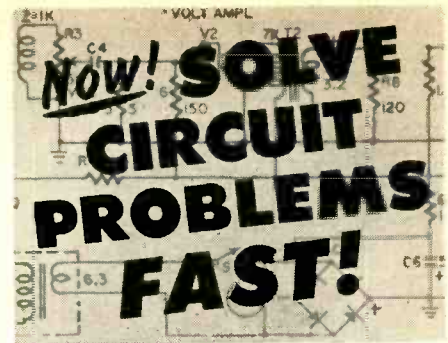

Goodbye to trial-and-error methods. Every circuit calculation you need can now be done accurately with

THE ALGEBRA OF ELECTRONICS

YOU'LL BE AMAZED at how easy it is to figure resistances, load inductances, impedances, etc. for ANY part of ANY electronic circuit. With this new book, THE ALGEBRA OF ELECTRONICS, you will quickly gain the tools, techniques and shortcuts needed.

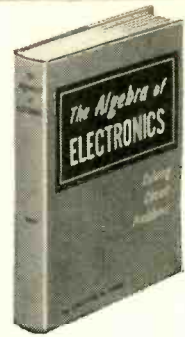

Three Great Books in One!

First, it's a textbook. All practical mathematical techniques explained clearly step-by-step; easy to follow by those with no more math training than high-school algebra and simple differential calculus.

Second, it's a handbook. Graphs and tables answer common electronic problems for those not wishing to work out complex derivations themselves.

Third, it's a review. Every equation is discussed, along with its practical on-the-job applications. 100 problems are shown with methods and answers provided.

THE ALGEBRA OF ELECTRONICS was written by Chester H. Page, Consultant to the Director of the National Bureau of Standards. Dr. Page discusses basic laws and fundamental principles, practical method of solving simultaneous equations. He develops elementary Fourier wave-form analysis, shows effects of frequency selectivity, modulation, and analyzes tubes, transistors and power supplies.

Try It FREE for 10 Days

Whether you're a repairman, technician, or engineer, you'll find THE ALGEBRA OF ELECTRONICS both profitable and interesting. Send coupon for a FREE 10-DAY EXAMINATION. No obligation — unless you want to keep the book. Mail coupon today to

D. Van Nostrand Co., Inc.
Dept. 181, Princeton, N.J.
Established 1848

127 TOPICS
340 Pages 252 Illustrations
<ul style="list-style-type: none"> Nonlinear Resistance Network Topology Mesh Currents Kirchoff's Law Voltage Variabes Triangularization Simultaneous Equations Kramer's Rule Thevenin's Theorem Wheatstone Bridge Conjugacy Black-Box Variables Image Impedances Attenuators Capacitance Dielectrics Simultaneous Voltage Energy Storage Series-Tuned Circuits Series Resonance Complex Phasors Mutual Inductance Transformers Critical Coupling F-M Discriminator Impedance Matching Hyperbolic Functions Diodes Amplifiers Transistors Thermal Noise Demodulation —many more

new "LEADER" test instrument

LAG-55 AUDIO GENERATOR SINE SQUARE

A multi-purpose generator for measurements on audio equipment—amplifiers, speakers, networks. Three waveforms: sine, square and complex for all types of measurements including response, distortion, transient and I-M distortion checks. Full range is from 20 to 200,000 cps, output 5 volts with minimum amplitude variation throughout whole range.



The LEADER test instruments are being used in the more than 36 countries, attesting their excellence in design, performance and usefulness.

OHMATSU ELECTRIC CO. LTD.

850 TSUASHIMA-CHO KOHOKU-KU YOKOHAMA, JAPAN

D. VAN NOSTRAND COMPANY, INC.

Dept. 181, PRINCETON, N. J.

Send for free examination—THE ALGEBRA OF ELECTRONICS. If I don't feel it can make electronic calculations clearer, easier, and faster, I may return it within 10 days; owe nothing. Otherwise, I will pay \$2.75 down, plus small delivery cost, and \$3 per month for 2 months.

Name _____ (Please Print Plainly)
Address _____
City _____ Zone _____ State _____

SAVE! Enclose \$8.75 WITH coupon and we will pay ALL shipping costs. Same ten-day money-back privilege.

(In Canada: 25 Hollinger Rd., Toronto 16. Price slightly higher.)

Foreign and A.P.O.—please send \$8.75 with order.

RAD-TEL

GUARANTEED



RAD-TEL'S FIRST QUALITY

**WHY PAY MORE? - BUY
DIRECT FROM RAD-TEL
FOR SAVINGS AND
PERFORMANCE
IN RADIO AND
TV TUBES**



Up to 75% OFF on BRAND NEW TUBES

GUARANTEED ONE FULL YEAR!

You Can Rely On Rad-Tel's Speedy One Day Service!

NOT USED — NOT PULLED OUT OF OLD SETS • EACH TUBE INDIVIDUALLY AND ATTRACTIVELY BOXED!

Qty.	Type	Price	Qty.	Type	Price	Qty.	Type	Price	Qty.	Type	Price	Qty.	Type	Price	Qty.	Type	Price
—	0Z4M	.79	—	4BQ7	.96	—	6AR5	.55	—	6CG7	.60	—	6SA7GT	.76	—	8EB8	.94
—	1AX2	.62	—	4BS8	.98	—	6AS5	.60	—	6CG8	.77	—	6SK7	.74	—	10DA7	.71
—	1B3GT	.79	—	4BU8	.71	—	6AT6	.43	—	6CM7	.66	—	6SL7	.80	—	11CY7	.75
—	1DN5	.55	—	4BZ6	.58	—	6AT8	.79	—	6CN7	.65	—	6SN7	.65	—	12A4	.60
—	1G3	.73	—	4BZ7	.96	—	6AU4	.82	—	6CR6	.51	—	6SQ7	.73	—	12AB5	.55
—	1J3	.73	—	4CS6	.61	—	6AU6	.50	—	6CS6	.57	—	6T4	.99	—	12AC6	.49
—	1K3	.73	—	4DE6	.62	—	6AU7	.61	—	6CU5	.58	—	6U8	.78	—	12AD6	.57
—	1L6	1.05	—	4DK6	.60	—	6AU8	.87	—	6CU6	1.08	—	6V6GT	.54	—	12AE6	.43
—	1LN5	.59	—	4DT6	.55	—	6AV6	.40	—	6CY5	.70	—	6W4	.75	—	12AF3	.73
—	1R5	.62	—	5AM8	.79	—	6AW8	.89	—	6CY7	.71	—	6W6	.69	—	12AF6	.49
—	1S5	.51	—	5AN8	.86	—	6AX4	.65	—	6DA4	.68	—	6X4	.39	—	12AJ6	.46
—	1T4	.58	—	5AQ5	.52	—	6AX7	.64	—	6DB5	.69	—	6X5GT	.53	—	12AL5	.45
—	1U4	.57	—	5AT8	.80	—	6BA6	.49	—	6DE6	.58	—	6X8	.77	—	12AL8	.95
—	1U5	.50	—	5BK7A	.82	—	6BC5	.54	—	6DG6	.59	—	7AU7	.61	—	12AQ5	.52
—	1X2B	.82	—	5BQ7	.97	—	6BC7	.94	—	6DQ6	1.10	—	7A8	.88	—	12AT6	.43
—	2AF4	.96	—	5BR8	.79	—	6BC8	.97	—	6DT5	.76	—	7B6	.69	—	12AT7	.76
—	3AL5	.42	—	5CG8	.76	—	6BD6	.51	—	6DT6	.53	—	7Y4	.69	—	12AU6	.50
—	3AUG	.51	—	5CL8	.76	—	6BE6	.55	—	6EU8	.79	—	8AU8	.83	—	12AU7	.60
—	3AV6	.41	—	5EA8	.80	—	6BF6	.44	—	6EA8	.79	—	8AW8	.93	—	12AV5	.97
—	3BA6	.51	—	5E8	.80	—	6BG6	1.66	—	6H5GT	.58	—	8BQ5	.60	—	12AV6	.41
—	3BC5	.54	—	5J6	.68	—	6BH6	.65	—	6J5GT	.51	—	8CG7	.62	—	12AV7	.75
—	3BE6	.52	—	5T8	.81	—	6BH8	.87	—	6J6	.67	—	8CM7	.68	—	12AX4	.67
—	3BN6	.76	—	5U4	.60	—	6BJ6	.62	—	6K6	.79	—	8CN7	.97	—	12AX7	.63
—	3BU8	.78	—	5U8	.81	—	6BK7	.85	—	6S4	.48	—	8CX8	.93	—	12AZ7	.86
—	3BY6	.55	—	5V6	.56	—	6BL7	1.00	—								
—	3BZ6	.55	—	5X8	.78	—	6BN4	.57									
—	3CB6	.54	—	5Y3	.46	—	6BN6	.74									
—	3CF6	.60	—	6AB4	.46	—	6BN6	.74									
—	3C56	.52	—	6AC7	.96	—	6BQ5	.65									
—	3CY5	.71	—	6AF3	.73	—	6BQ6GT	1.05									
—	3DK6	.60	—	6AF4	.97	—	6BQ7	.95									
—	3DT6	.50	—	6AG5	.65	—	6BR8	.78									
—	3Q5	.80	—	6AG5	.65	—	6BU8	.70									
—	3S4	.61	—	6AH6	.99	—	6BY6	.54									
—	3V4	.58	—	6AK5	.95	—	6BZ6	.54									
—	4BC5	.56	—	6AL5	.47	—	6BZ7	.97									
—	4BC8	.96	—	6AM8	.78	—	6C4	.43									
—	4BN6	.75	—	6AN4	.95	—	6CB6	.54									
—			—	6AN8	.85	—	6CD6	1.42									
—			—	6AQ5	.50	—	6CF6	.64									

TRANSISTORS — AT FABULOUS DISCOUNTS

	PRICE	TYPE	RATING	ELECTRICAL CHARACTERISTICS		HFC
<input type="checkbox"/>	RF 49¢	GE PNP ALLOY JUNCTION GENERAL PURPOSE RF/AF	200 MW	1CB0 max.	1EB0 max.	VCE = -1.5 lb = 5 ma 20 min
<input type="checkbox"/>	AF 39¢			20 μa VCB = -3V	20 μa VEB = -3V	
<input type="checkbox"/>	80¢ ea.	Power AF Med. Freq. To-3	MIN. POWER OUTPUT 2.25 W	20 ma VCB = -16V	20 ma VEB = -16V	VCE = -1.5 lb = 1 ma 40 min
<input type="checkbox"/>	140¢ ea.	Hi Power 15 AMP To 36		40 ma VCB = -100	40 ma VEB = -100	VCE = -1.5 lb = 1 ma 30 min

Series 830 OHMS

SEND FOR FREE TROUBLE SHOOTER GUIDE AND NEW TUBE & PARTS CATALOG.

NOT AFFILIATED WITH ANY OTHER MAIL ORDER TUBE COMPANY

RAD-TEL TUBE CO.

55 Chambers Street

Newark 5. N. J.

TERMS: 25% deposit must accompany all orders—balance C.O.D. \$1 HANDLING CHARGE FOR ORDERS UNDER \$5. Subject to prior sale. Please add postage. No C.O.D.'s outside continental U.S.A. Dept. RE-161.

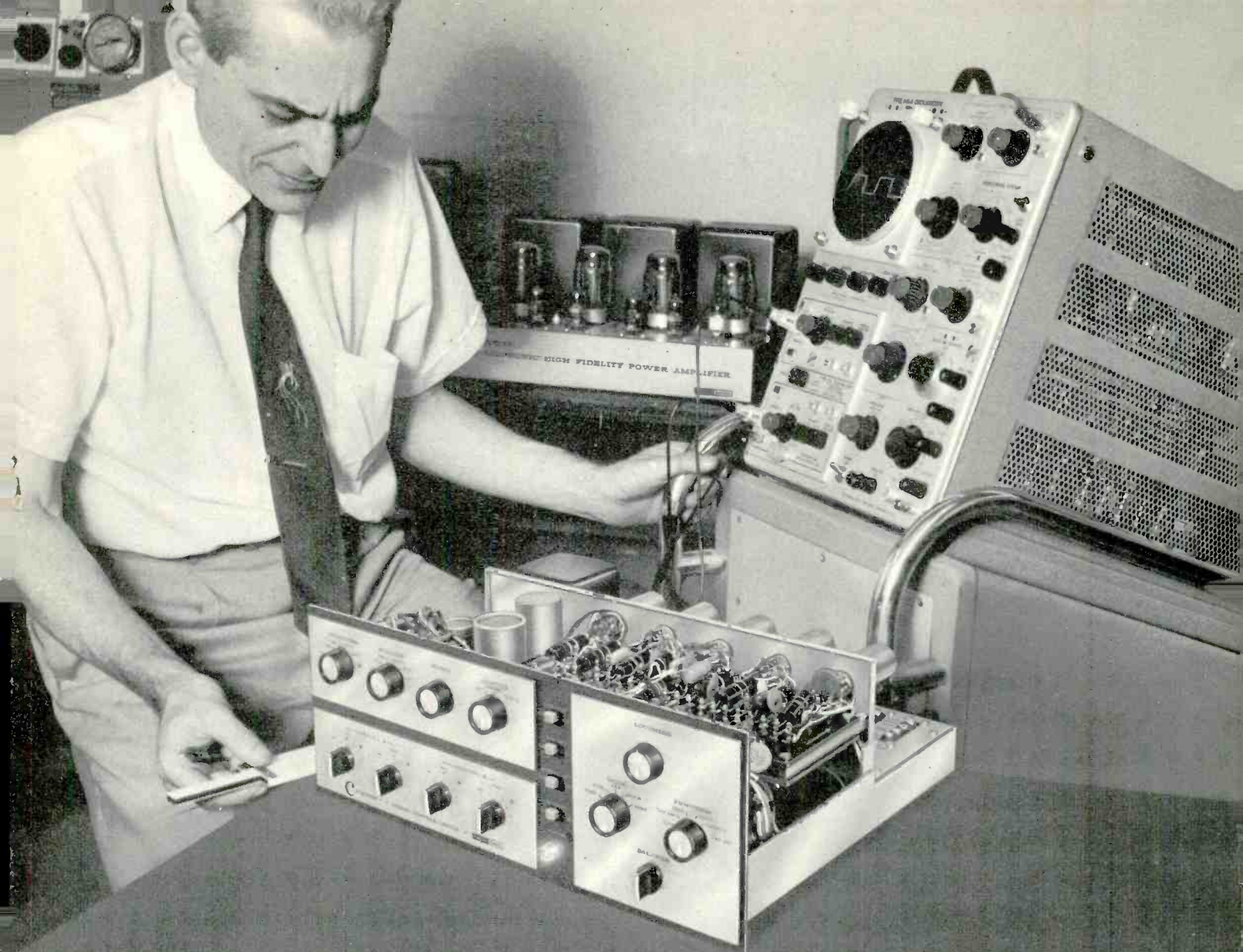

AT NORMAL LISTENING LEVELS THE ONLY MEASURABLE DISTORTION COMES FROM THE TEST EQUIPMENT!

Measuring intermodulation, harmonic or phase distortion on the new Citation Kits can be a unique experience for any engineer. He will find that *at normal listening levels the only measurable distortion comes from the test equipment.*

But let's put the numbers away. The real distinction of Citation is not in its specifications — remarkable as they are. It is, rather, in its performance — which goes well beyond the point of numbers. *Citation actually sounds recognizably best.* The "Citation Sound" has created so profound an impression, that the words have become part of the language of high fidelity.

In AUDIO MAGAZINE, editor C. G. McProud, wrote: *"When we heard the Citations, our immediate reaction was that one listened through the amplifier system clear back to the original performance, and that the finer nuances of tone shading stood out clearly and distinctly for the first time."*

The basic quality of the "Citation Sound" was summed up by the Hirsch-Houck Labs in HIGH FIDELITY: *"The more one listens...the more pleasing its sound becomes."* Another glowing tribute to Citation and its talented engineering group, headed by Stew Hegeman (shown above), came from Herbert Reid who said in HI-FI STEREO REVIEW: *"Over and above the details of design and performance, we felt that the Citation group bore eloquent witness to the one vital aspect of audio that for so many of us has elevated high fidelity from a casual hobby to a lifelong interest: the earnest attempt to reach an ideal — not for the sake of technical showmanship — but for the sake of music and our demanding love of it."*

THE CITATION I, Stereophonic Preamplifier Control Center... \$159.95; Factory-Wired ... \$249.95; Walnut Enclosure, WC-1... \$29.95.

THE CITATION II, 120 Watt Stereophonic Power Amplifier... \$159.95; Factory-Wired ... \$229.95; Charcoal Brown Enclosure, AC-2... \$7.95. All prices slightly higher in the West.

For a complete report on these remarkable instruments, write Dept. RE-1, Citation Kit Division, Harman-Kardon, Plainview, N. Y.

Build the Very Best **CITATION KITS** by **harman kardon**

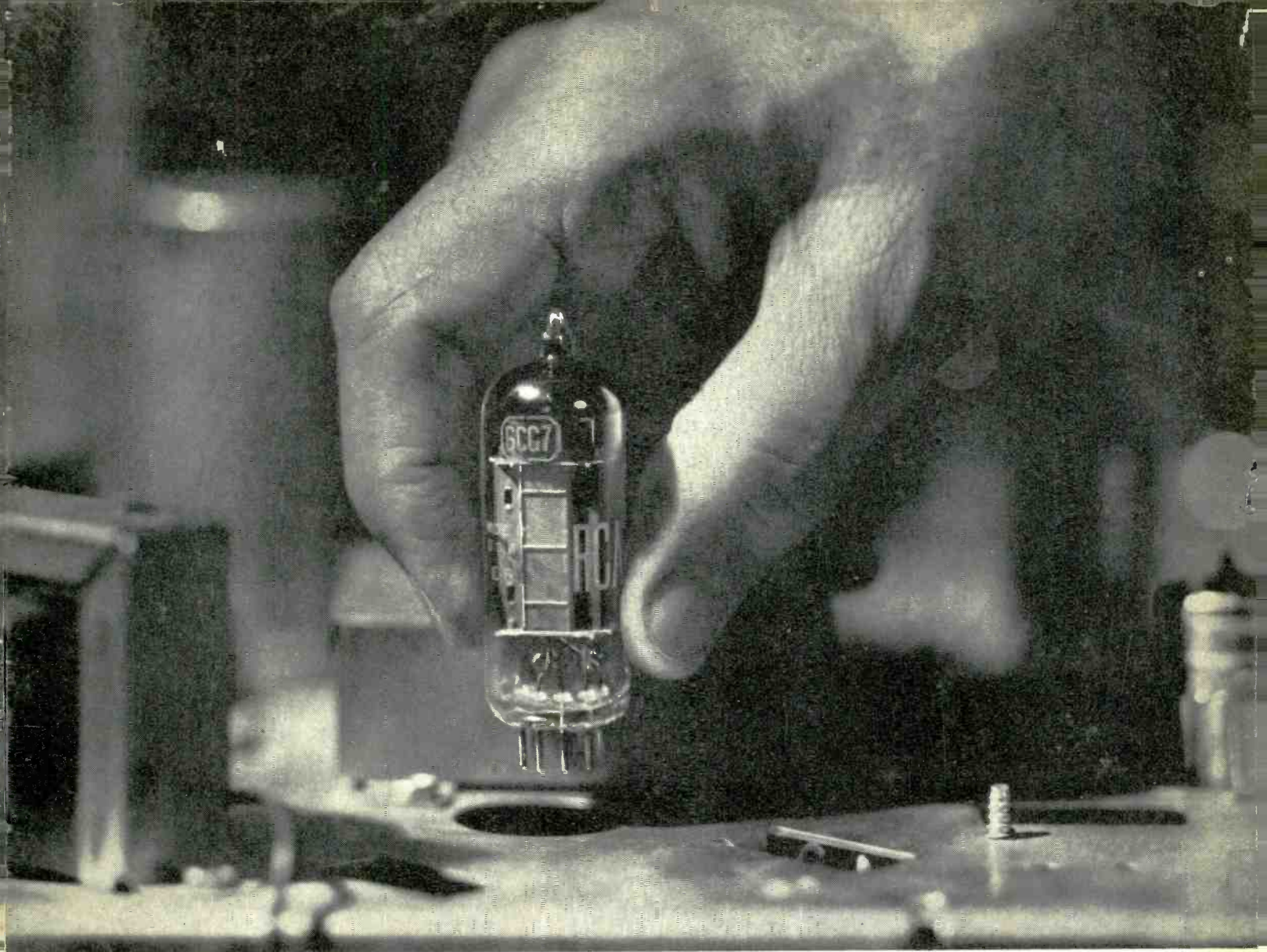

WHEN YOU REPLACE A TUBE . . .

You have a lot at stake each time you replace a receiving tube in a customer's set. Your professional reputation, your customer's confidence, your day's profits—even future business—all depend on the quality of that replacement tube.

It is RCA's constant aim to provide receiving tubes you can install with confidence. To this end, RCA carefully controls every step of the tube making process from initial design to final test.

QUALITY BY DESIGN—Some of the foremost tube experts in the industry collaborate on each new RCA tube design. Engineers, chemists, physicists, metallurgists, production specialists, field representatives, all contribute their own skills and knowledge before a new RCA tube design ever leaves the drafting board.

IMPROVED QUALITY FROM NEW AND IMPROVED MATERIALS—All parts and materials in RCA tubes are either *produced* or *processed* by RCA under strictest quality control. Moreover, RCA scientists search constantly for new and better materials which will still further improve performance of RCA tubes. Many tube types you install today benefit from new cathode and plate materials developed in RCA labs.

QUALITY IN MANUFACTURING—Because tube construction is just as important as design and materials, RCA maintains a system of supervisory microscopic inspection at key points on every production line to detect any flaw in assembly. And to minimize the chance of human error, RCA has automated certain critical steps in tube production.

QUALITY BY TESTING AND CONTROL—Before shipment, *every single RCA receiving tube* is factory-tested for every significant characteristic. *A tube that fails one single test is rejected and destroyed. So there is no such thing as a "second" when you buy RCA.* In addition, thorough aging of tubes and rating-lab tests assure strict adherence to performance specifications.

This is why YOU CAN REPLACE WITH CONFIDENCE with RCA tubes . . . and why RCA tubes give you an extra advantage on every service job. Electron Tube Division, Harrison, N. J.



The Most Trusted Name in Electronics
RADIO CORPORATION OF AMERICA